

THIS DRAWING IS UNPUBLISHED.

RELEASED FOR PUBLICATION

LOC

DIST

REVISIONS

© COPYRIGHT - By -

ALL RIGHTS RESERVED.

FT

0

P

LTR

DESCRIPTION

DATE

DWN

APVD

H2

REVISED PER ECO-11-004917

11MAR11

RK

HMR

- 1 MATERIAL: BODY - COPPER ALLOY
BAND - BeCu
- 2 FINISH: BODY AND BAND - .0002 IN. SILVER
OVER .00004 IN. NICKEL.
- 3. WIRE BARREL WILL ACCEPT 12-14 AWG WIRE.
- 4. MATES WITH AMP PART NUMBER 193841-1.
- 5 FINISH: BODY - 30 uIN GOLD MIN. OVER 50 uIN
NICKEL MIN. BAND- GOLD
- 6 FINISH: BODY AND BAND -
AT MINIMUM, HARD GOLD FLASH OVER 40 uINCHES
80-20 Pd/Ni OVER 100 uINCHES NICKEL.
- 7. ALL DIMENSIONS ARE REFERENCE.

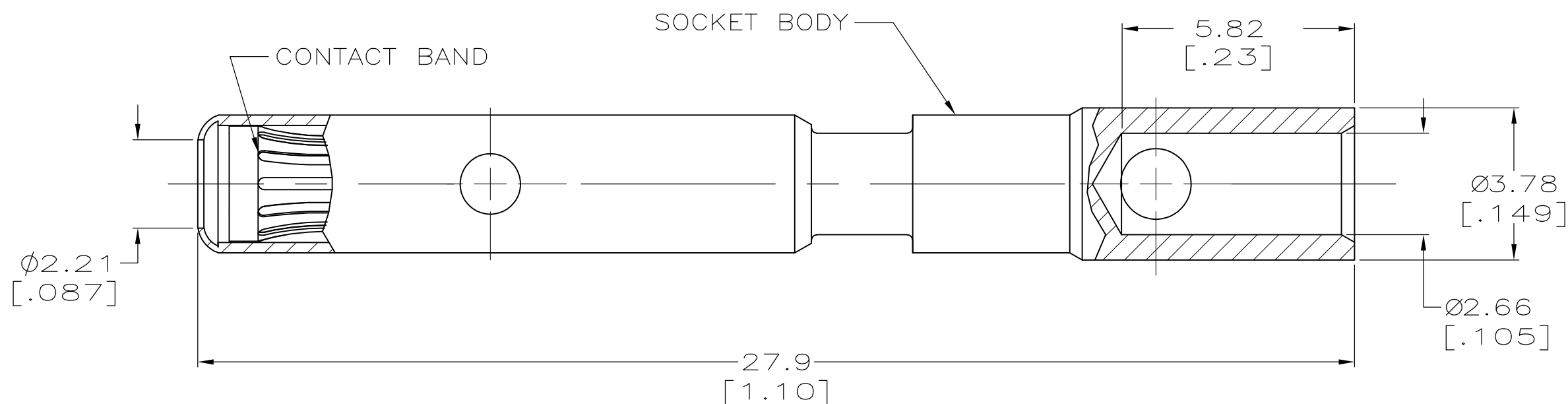

	6	193842-3
OBSOLETE	5	193842-2
	2	193842-1
FINISH		PART NO.

THIS DRAWING IS A CONTROLLED DOCUMENT.		DWN	03-18-94		STE TE Connectivity		
		CHK	C. M. SVOBODA				
DIMENSIONS: mm [INCHES]		TOLERANCES UNLESS OTHERWISE SPECIFIED:		NAME			
		0 PLC ± -		PRODUCT SPEC			
		1 PLC ± -		APPLICATION SPEC			
		2 PLC ± -		SIZE			
		3 PLC ± -		CAGE CODE			
4 PLC ± -		4 PLC ± -		DRAWING NO			
ANGLES ± -		FINISH		RESTRICTED TO			
MATERIAL		1		A300779 C-193842			
CUSTOMER DRAWING				SCALE	SHEET		REV
				1 OF 1		H2	

单击下面可查看定价，库存，交付和生命周期等信息

[>>TE Connectivity\(泰科\)](#)