

THIS DRAWING IS UNPUBLISHED.  
 DIFFUSION RESTREINTE AMP  
 © COPYRIGHT - By -  
 ALL RIGHTS RESERVED.  
 TOUS DROITS RESERVES

LOC	DIST	REVISIONS			
P	LTR REV	DESCRIPTION MODIFICATIONS	DATE	DWN DESS.	APVD APP.
F	7	F1 REVISED PER ECO-11-005150	21MAR11	RK	HMR

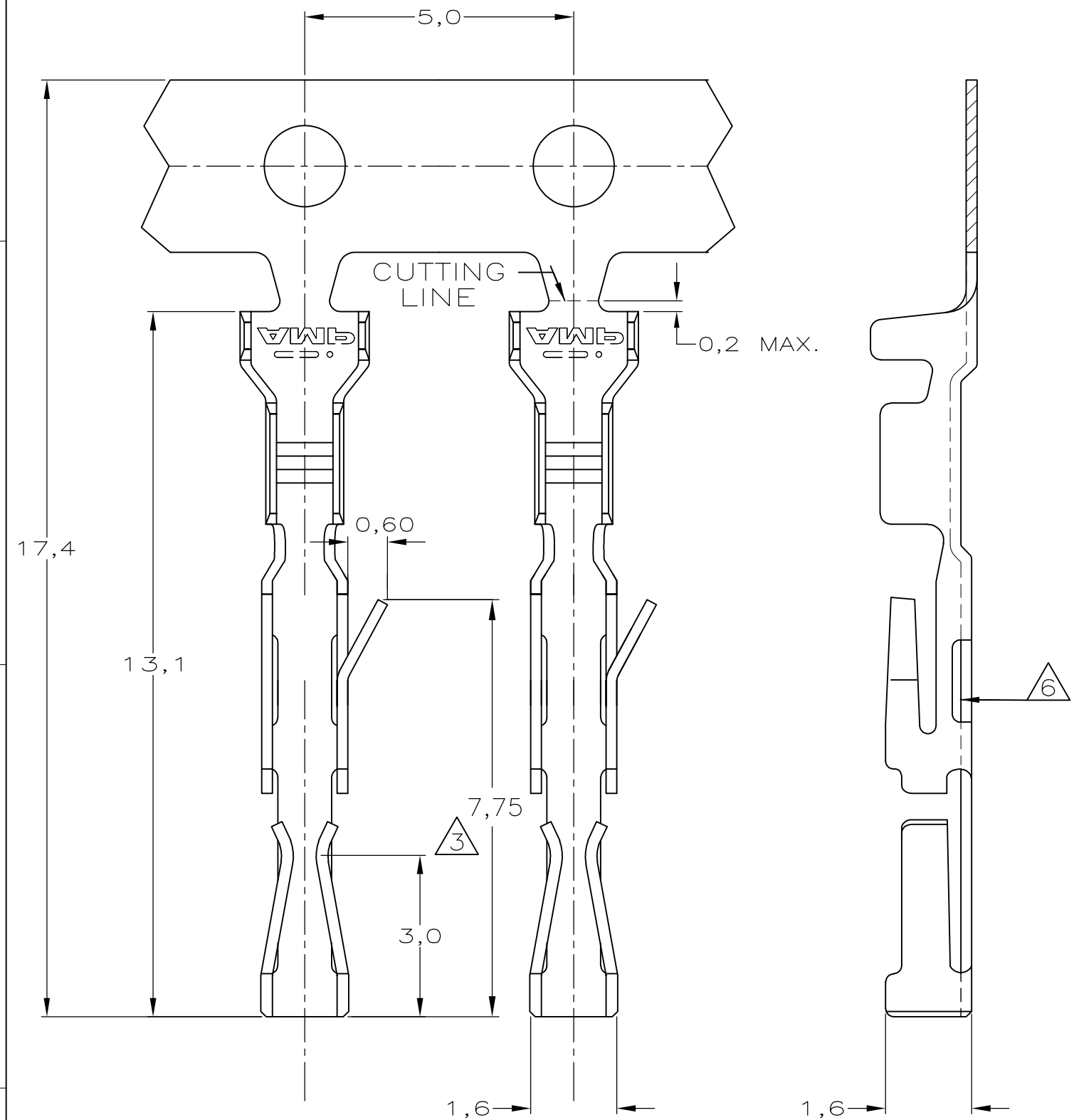

NOTES:

- ① CONTACT MATERIAL: PHOSPHORBRONZE
- ② PLATING: UNDERCOATING 1,3 μm Ni OVERALL  
 AT CONTACTPLACE 0,8μm Au  
 AT CRIMPBARRELS 2,5μm Sn
- ③ CONTACT POINT
- ④ BOTTOM OF CONTACT TO BE STRAIGHT AFTER CRIMPING OF WIRE
- 5 WIRE RANGE: 0,08-0,22mm<sup>2</sup>  
 INSULATION RANGE: 0,80-1,50 DIA.
- ⑥ OPTIONAL
- 7 THE CONTACT MEETS THE REQUIREMENT OF INTERNATIONAL STANDARD IEC 603-8

LOOSE PIECE	②	①	182734-3
STRIP	②	①	188746-1
CONFIGURATION	FINISH	MATERIAL	PARTNUMBER

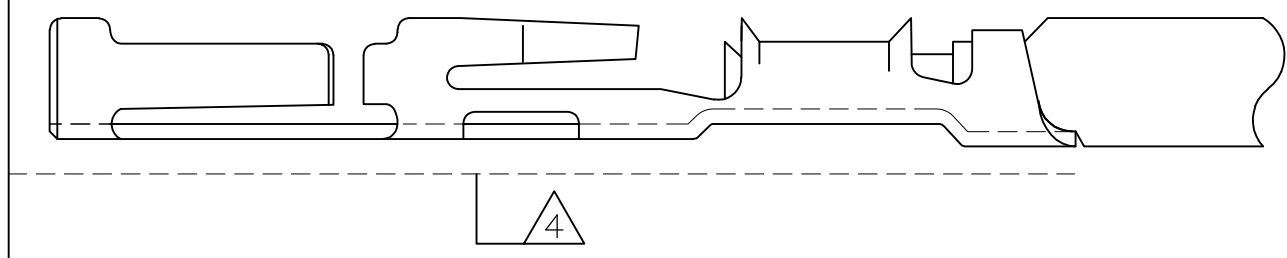

THIS DRAWING IS A CONTROLLED DOCUMENT.  
 CE PLAN EST UN DOCUMENT CONTROLE

DIMENSIONS: mm	TOLERANCES UNLESS OTHERWISE SPECIFIED: TOLERANCES NON SPECIFIEES (SUIV NB DE DECIMALES): 0-PLC/DEC ± - 1-PLC/DEC ± 0.3 2-PLC/DEC ± - 3-PLC/DEC ± - 4-PLC/DEC ± - ANGLES ± 1	DWN/DESSINE JJ DESPRETZ 22-NOV-04 CHK/VERIFIE T CORRIOU APVD/APPROUVE Y PETRONIN PRODUCT SPEC SPEC. PRODUIT APPLICATION SPEC SPEC. APPLICATION	NAME TITRE HE 1302 CONNECTOR (GOLD VERSION) CRIMP CONTACT (AWG 28-24)
MATERIAL MATIERE	FINISH FINITION	WEIGHT MASSE APPROX. -	SIZE FORMAT A3

CUSTOMER DRAWING/PLAN CLIENT UNIQUEMENT POUR REFERENCE

SCALE ECHELLE 1:1	SHEET FEUILLE 1 OF 1	DRAWING NO No PLAN G-188746	RESTRICTED TO
----------------------	-------------------------	-----------------------------------	---------------

REV F1

单击下面可查看定价，库存，交付和生命周期等信息

[>>TE Connectivity\(泰科\)](#)