

LOC	DIST	REVISIONS					
GP	00	P	LTN	DESCRIPTION	DATE	DWN	APVD
		A		REVISED PER ECO-15-000199	13JAN2015	AP	DG
		B		REVISED PER ECO-17-013690	07AUG2017	JY	SH
		D		REVISED PER ECO-18-008478	10MAY2018	JY	SH

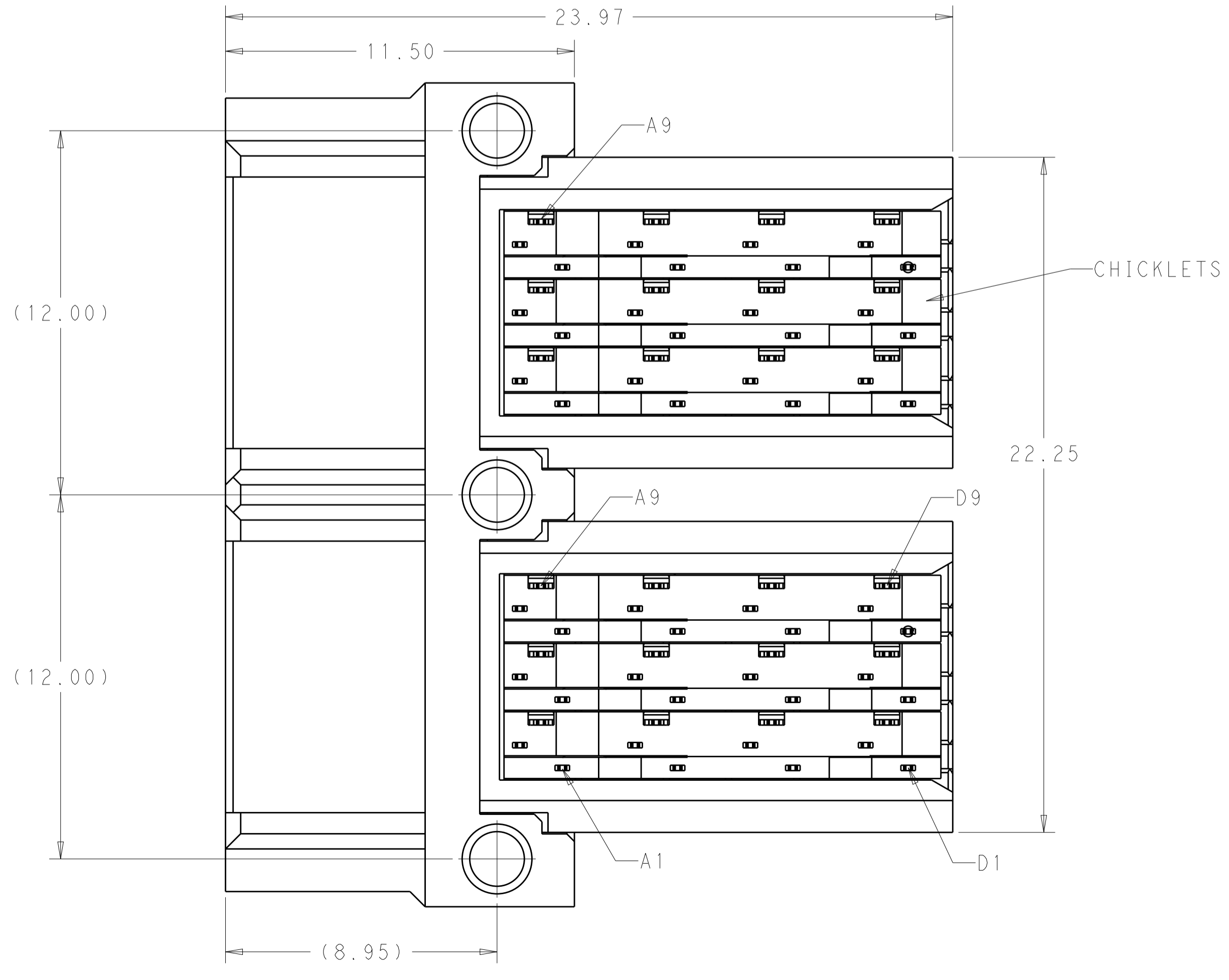

- ⚠ MATERIALS
 HOUSINGS AND CHICKLETS: LCP, BLACK, UL94V-0 RATED
 CONTACTS: COPPER ALLOY
- ⚠ CONTACT FINISH: CONFORMS TO THE REQUIREMENTS OF TE PRODUCT SPECIFICATION, 108-32038. BASED ON EIA/ECA-364-1000.01A. (CONTROLLED ENVIRONMENT APPLICATIONS) ON MATING END. TIN PLATED ON PCB TAIL
- 3. MATES WITH TE PLUG 2227603-1
- ⚠ MOUNTING HARDWARE M2x1.35 SELF-THREADING SCREW
 SCREW LENGTH OF FASTENER = PCB THICKNESS + 3.0mm MAX (1.75mm MIN)
 MOUNTING HARDWARE IS NOT SUPPLIED BY TE.
- ⚠ RECOMMENDED COMPONENT KEEP OUT ZONE.
- ⚠ PART NUMBER AND DATE CODE MARKED IN APPROXIMATE AREA SHOWN ON OPPOSITE SIDE.
- ⚠ MOUNTING HARDWARE M2x1.35 SELF-THREADING SCREW
 SCREW LENGTH OF FASTENER = PCB THICKNESS + 5.0mm MAX (1.75mm MIN)
 MOUNTING HARDWARE IS NOT SUPPLIED BY TE.
- ⚠ MOUNTING HARDWARE M2x0.0.78 OR M1.8x0.709 SELF-THREADING SCREW (DELTA PT® THREAD-FORMING FASTENER), SCREW LENGTH OF FASTENER = PCB THICKNESS + 5.0mm MAX (1.75mm MIN), MOUNTING HARDWARE IS NOT SUPPLIED BY TE.

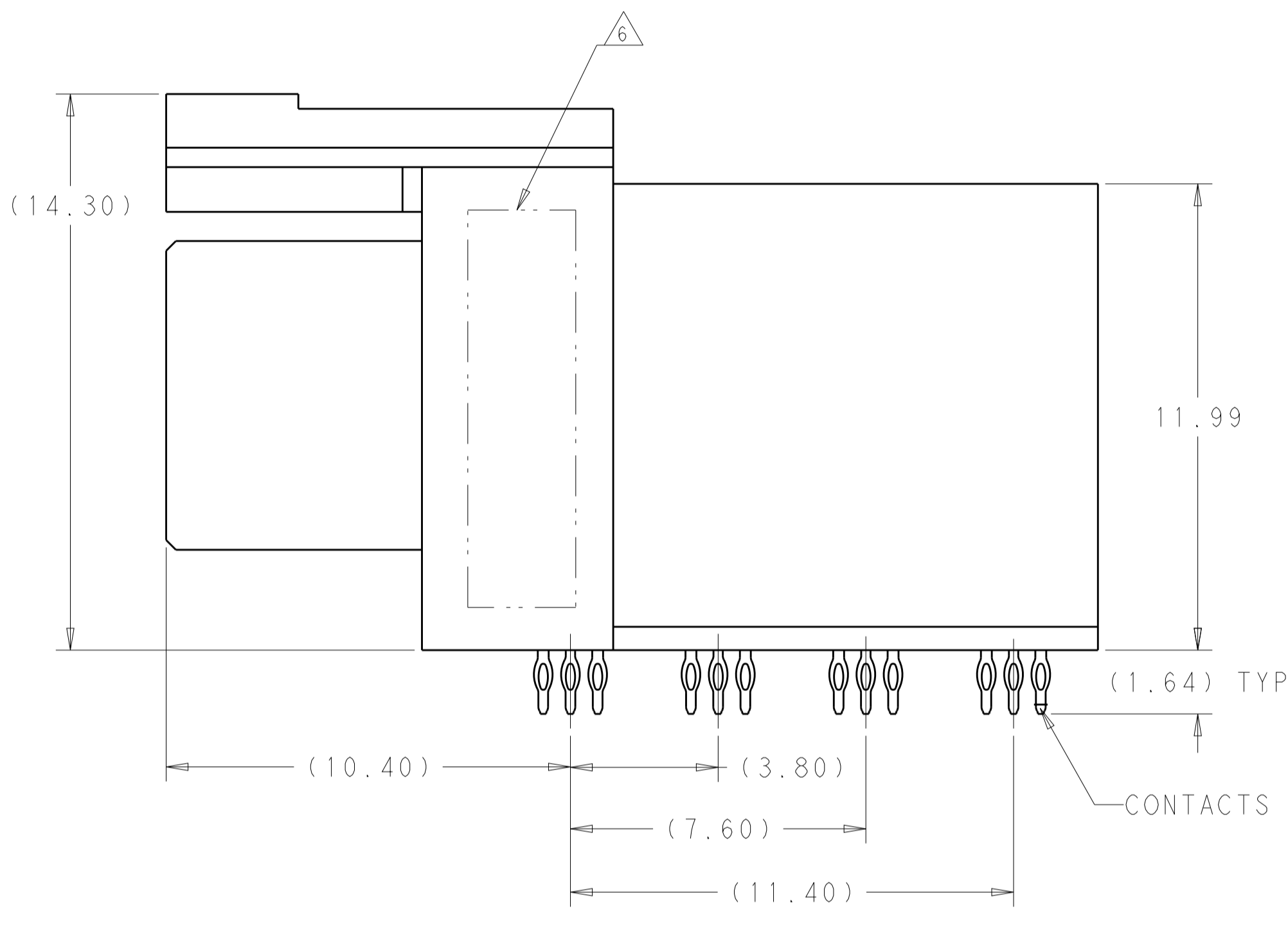
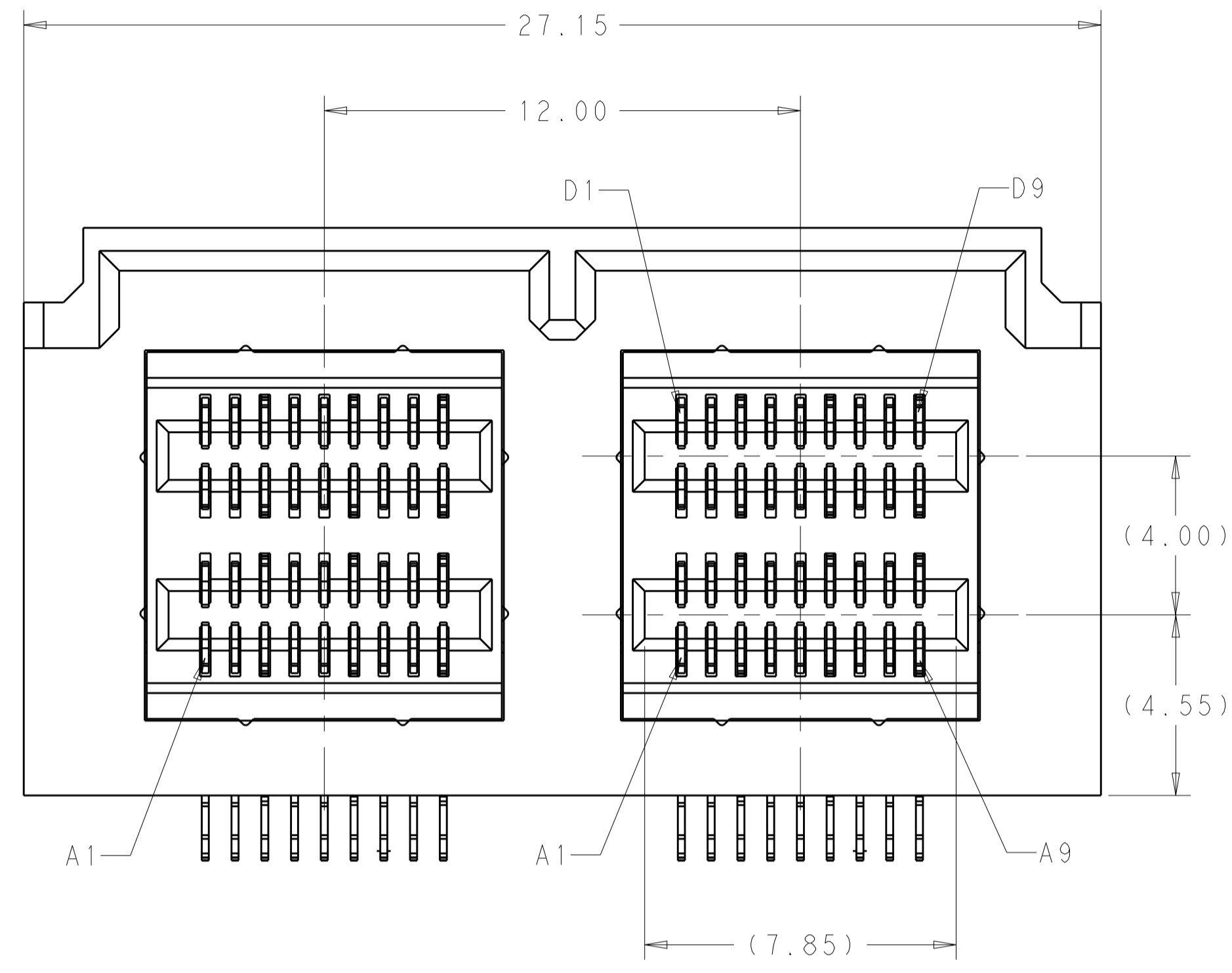
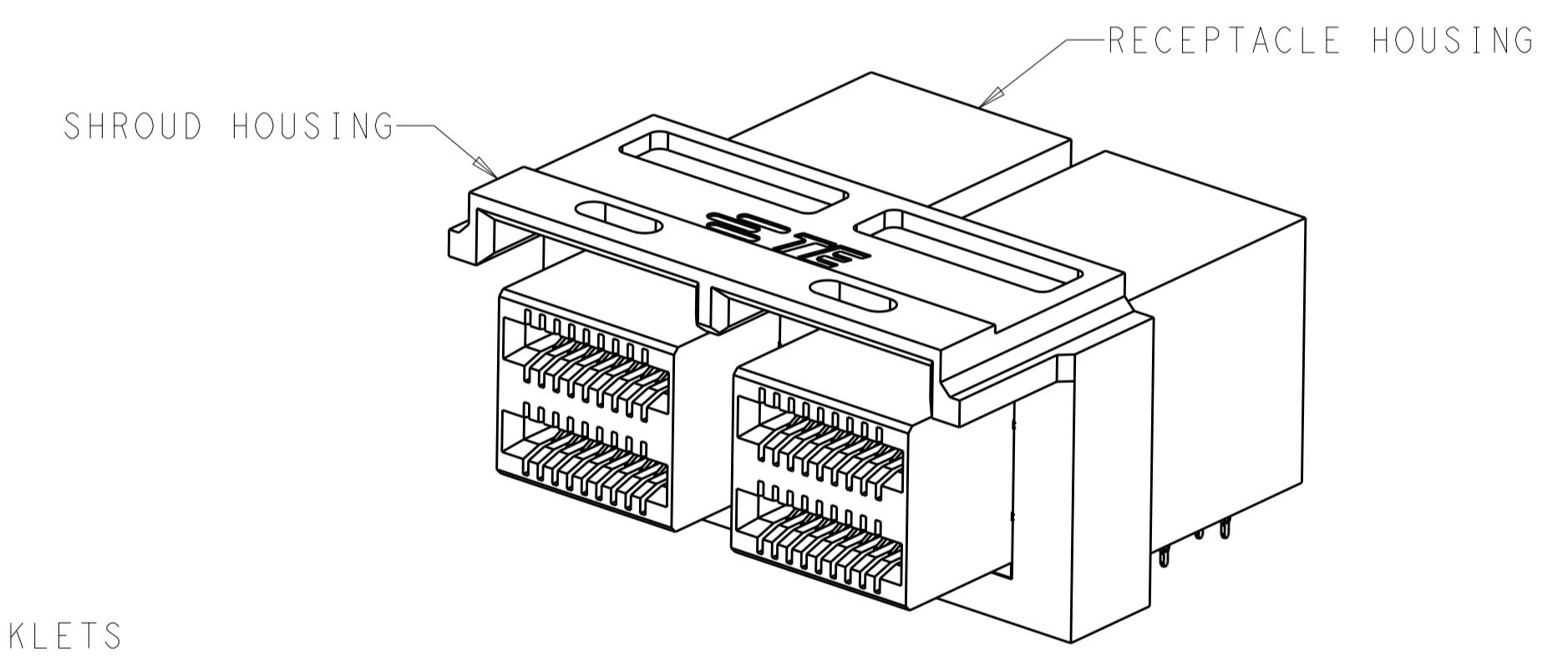

SCREW APPLICATION	DIAMETER OF SCREW HOLES	PART NUMBER
⚠	Ø1.60	2227581-3
⚠	Ø1.80	2227581-2
⚠	Ø1.80	2227581-1

THIS DRAWING IS A CONTROLLED DOCUMENT. DWN: R. TREA 19DEC2012
 CHK: R. HENRY 19DEC2012

DIMENSIONS:	TOLERANCES UNLESS OTHERWISE SPECIFIED:	NAME	RECEPTACLE ASSEMBLY, 1X2, RIGHT ANGLE, INTERNAL MINI-SAS HD
mm	0 PLC ± 2 PLC ±0.13 3 PLC ± 4 PLC ± ANGLES ±	PRODUCT SPEC	108-32038
		APPLICATION SPEC	114-32101
MATERIAL	FINISH	WEIGHT	SCALE 8:1 SHEET 1 OF 3 REV D

CUSTOMER DRAWING A100779C=2227581

LOC	DIST	REVISIONS			
P	LTN	DESCRIPTION	DATE	DWN	APVD
GP	00	- SEE SHEET 1	-	-	-

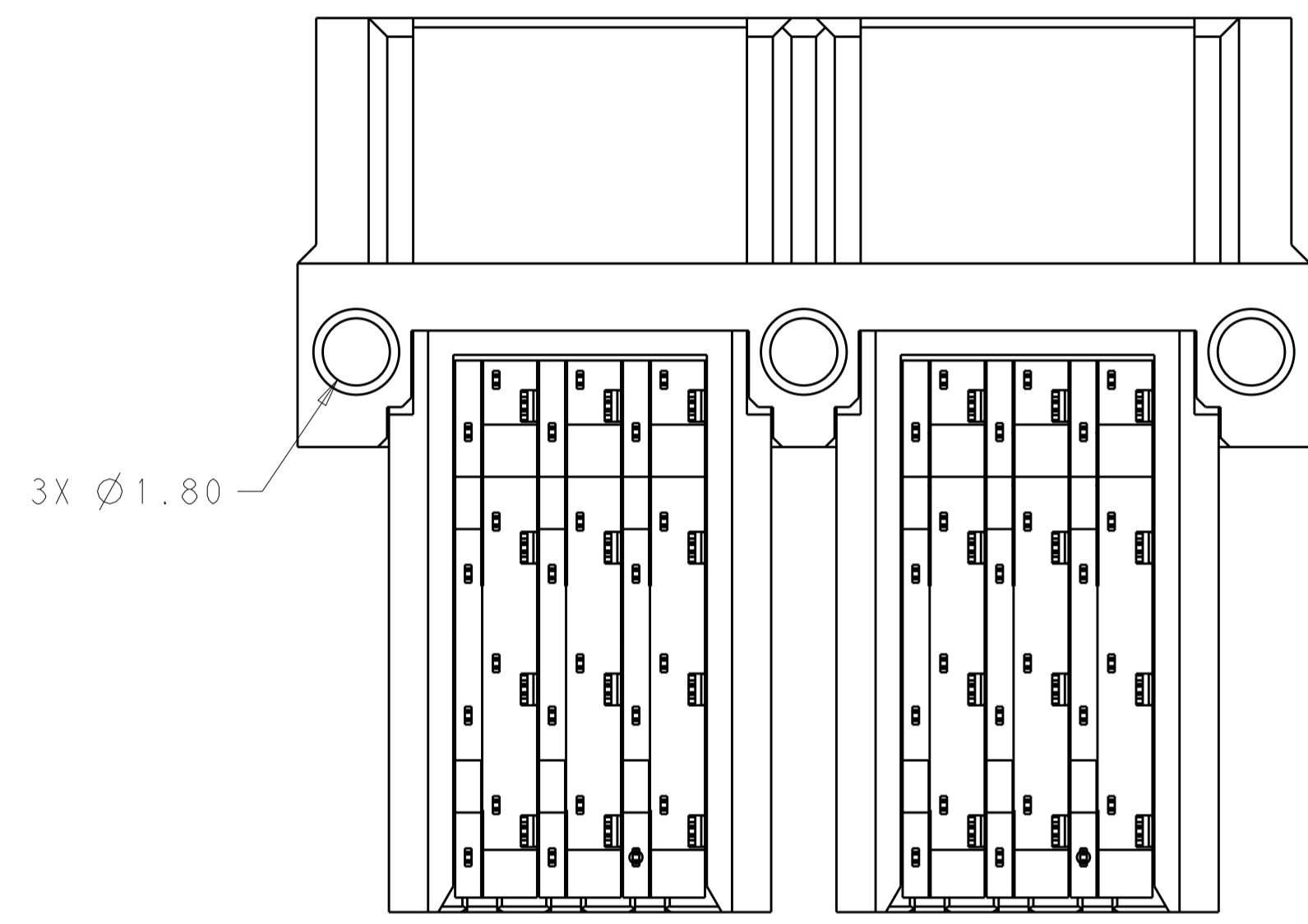

2227581-1
SCALE 6:1

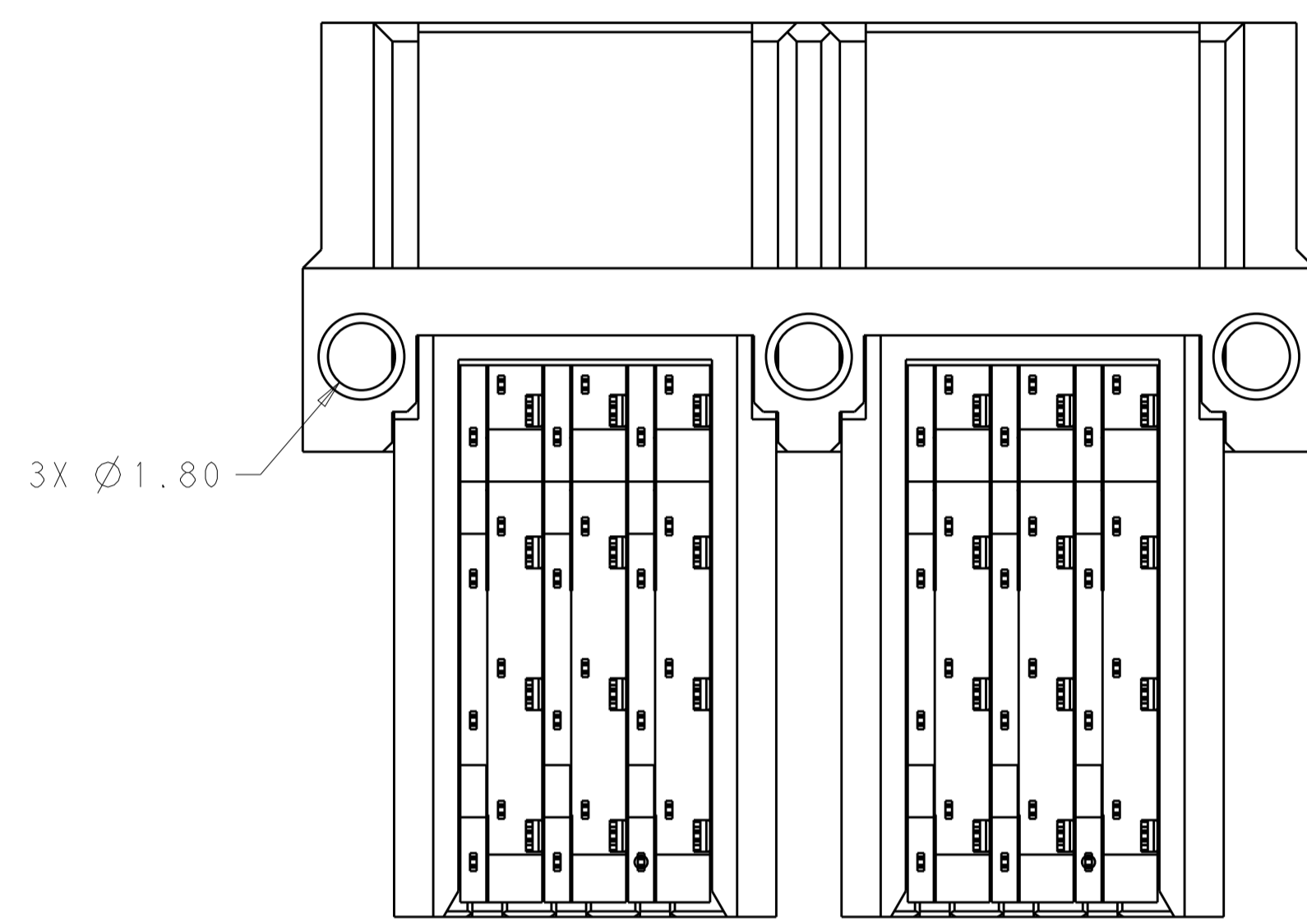

2227581-2
SCALE 6:1

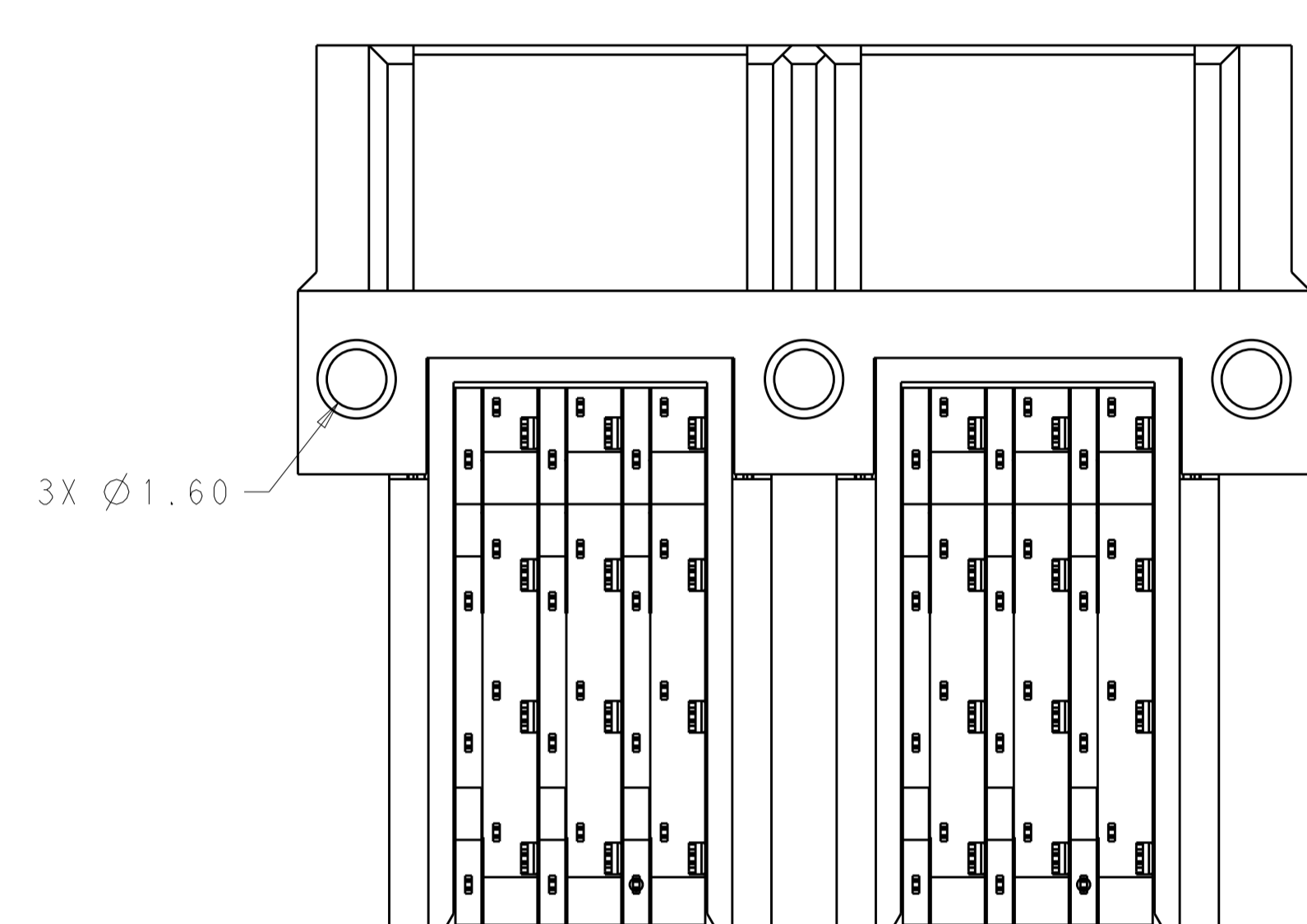

2227581-3
SCALE 6:1

THIS DRAWING IS A CONTROLLED DOCUMENT.		DWN R. IREDA 19DEC2012	
DIMENSIONS:		CHK R. HENRY 19DEC2012	
mm	TOLERANCES UNLESS OTHERWISE SPECIFIED:	APVD	NAME
0 PLC ±	1 PLC ±	PRODUCT SPEC	RECEPTACLE ASSEMBLY,
2 PLC ±0.13	3 PLC ±	108-32038	1X2, RIGHT ANGLE,
4 PLC ±	ANGLES ±	APPLICATION SPEC	INTERNAL MINI-SAS HD
MATERIAL	FINISH	114-32101	SIZE CAGE CODE DRAWING NO
		WEIGHT	A100779C=2227581
		CUSTOMER DRAWING	RESTRICTED TO
		SCALE 8:1	SHEET 2 OF 3
			REV D

LOC	DIST	REVISIONS					
GP	00	P	LTN	DESCRIPTION	DATE	DWN	APVD
		-		SEE SHEET 1	-	-	-

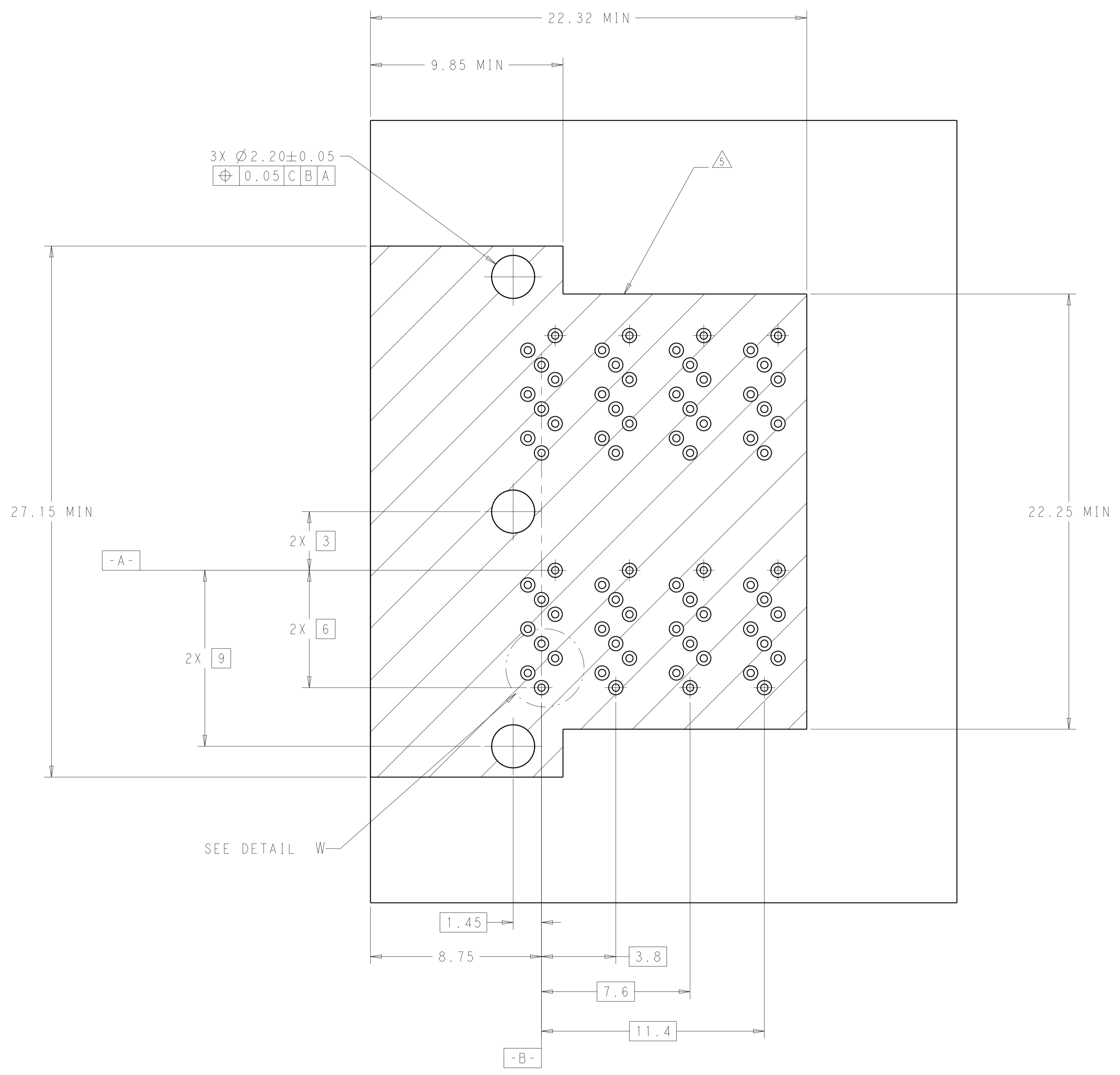

RECOMMENDED PCB LAYOUT
 SCALE 8:1

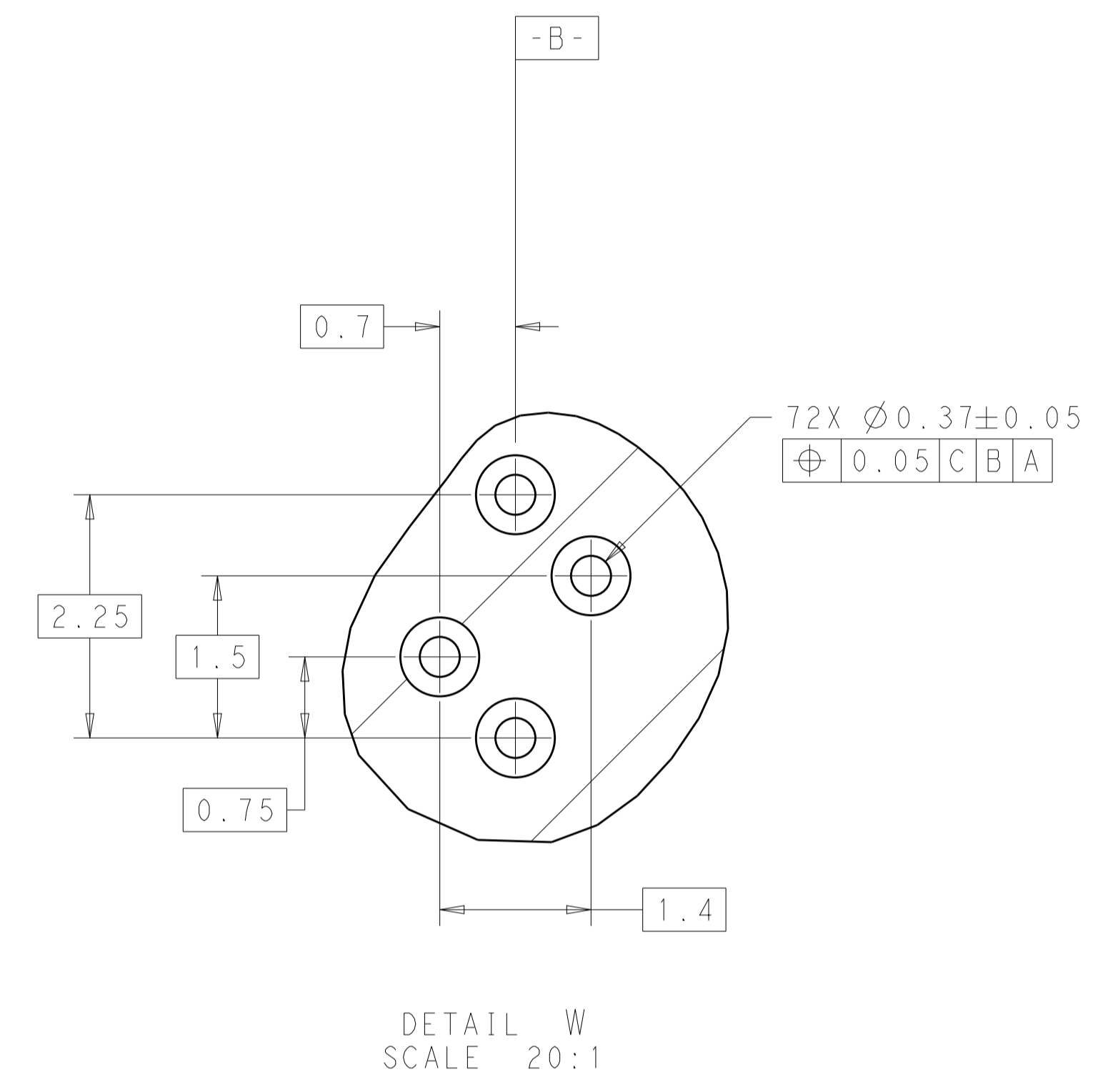

THIS DRAWING IS A CONTROLLED DOCUMENT.		DWN R. IREA 19DEC2012	TE Connectivity
DIMENSIONS: mm		CHK R. HENRY 19DEC2012	
TOLERANCES UNLESS OTHERWISE SPECIFIED: 0 PLC ± 1 PLC ±0.13 2 PLC ± 3 PLC ± 4 PLC ± ANGLES ± FINISH		APVD -	NAME RECEPTACLE ASSEMBLY, 1X2, RIGHT ANGLE, INTERNAL MINI-SAS HD
MATERIAL		PRODUCT SPEC 108-32038	RESTRICTED TO
		APPLICATION SPEC 114-32101	SIZE A100779C=2227581
		WEIGHT	SCALE 8:1 SHEET 3 OF 3 REV D
		CUSTOMER DRAWING	

单击下面可查看定价，库存，交付和生命周期等信息

[>>TE Connectivity\(泰科\)](#)