

LOC	DIST	REVISIONS			
P	LTR	DESCRIPTION	DATE	DMN	APVD
B		REVISED PER ECO-11-006470	30JUN11	HMR	SM

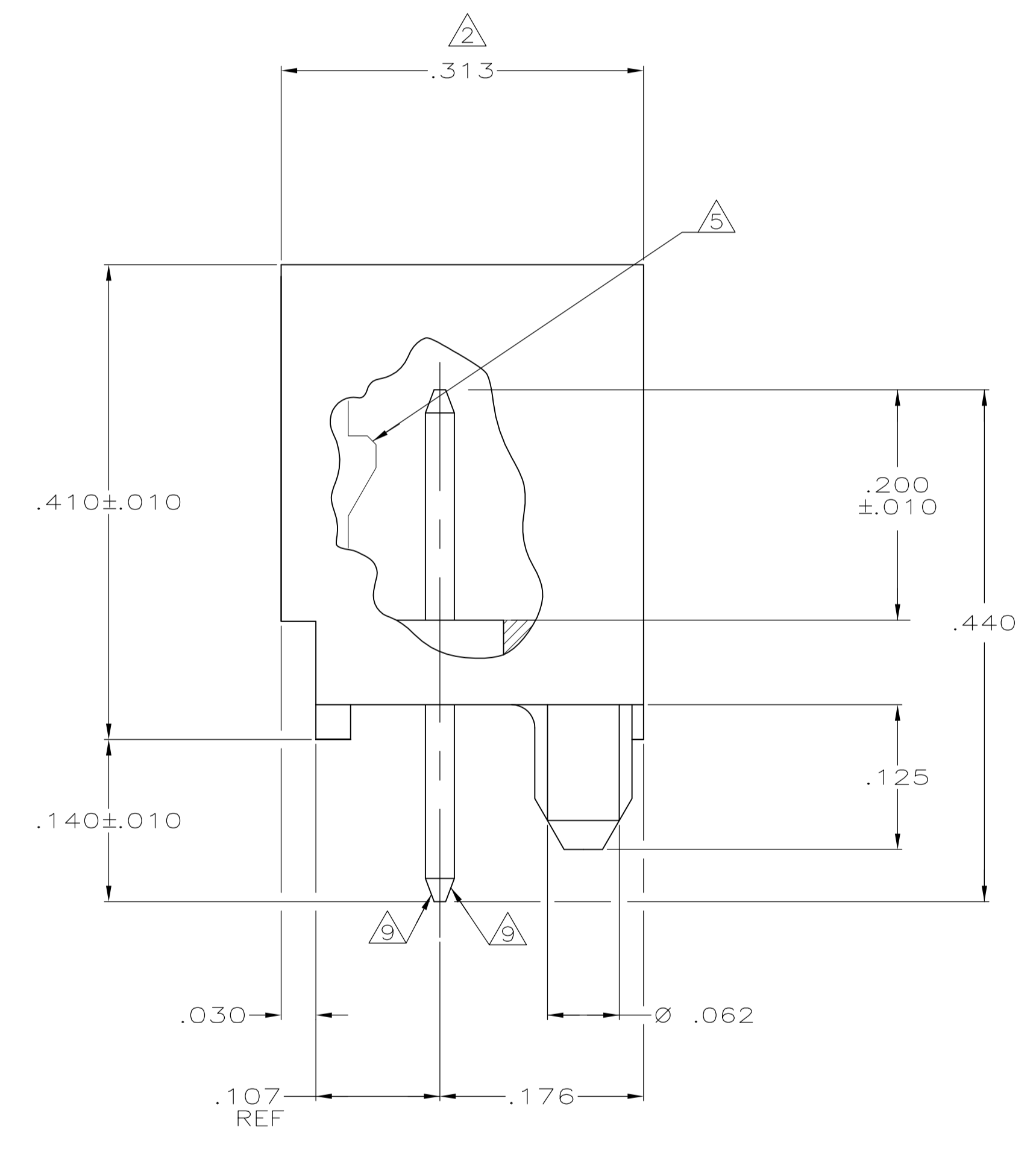
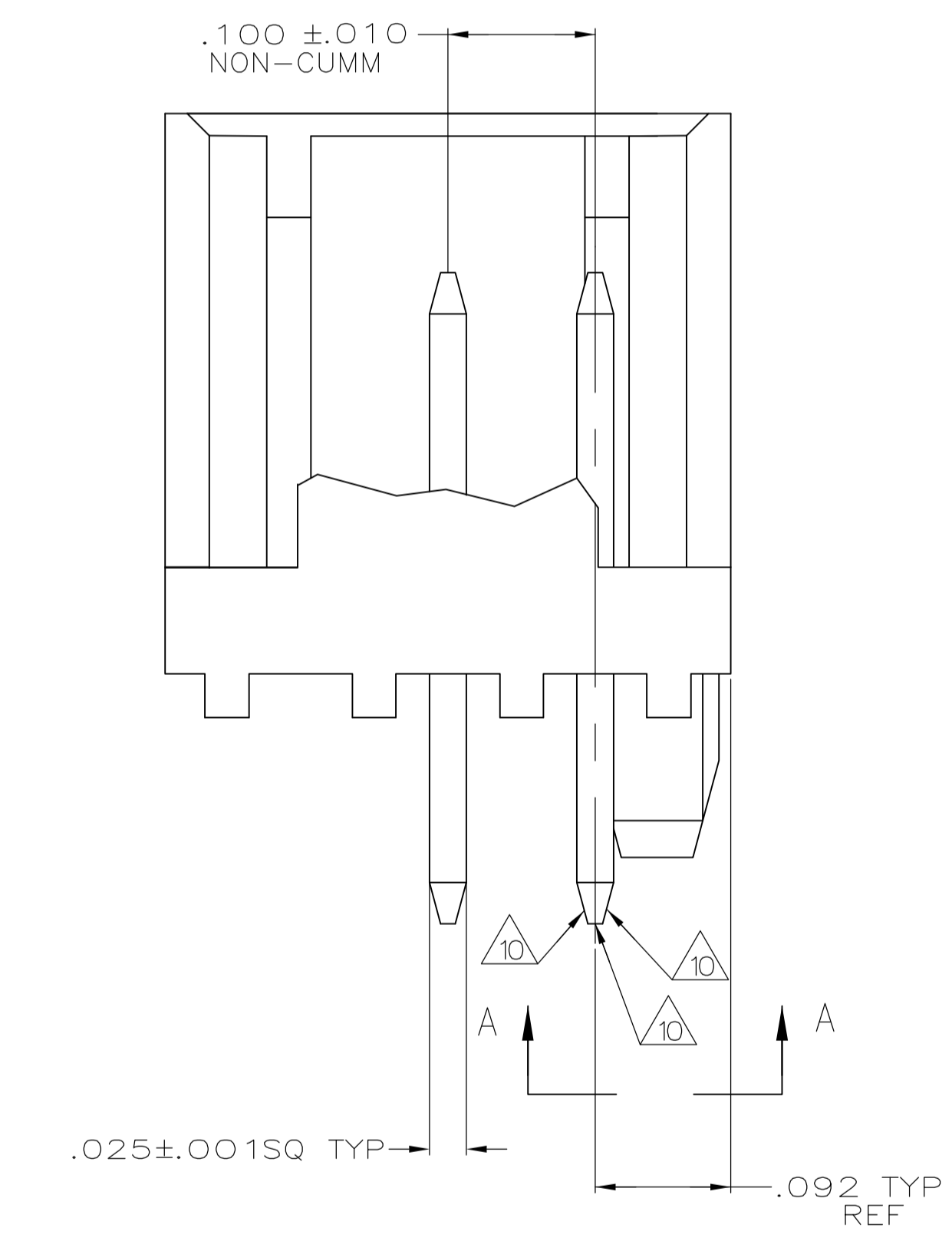
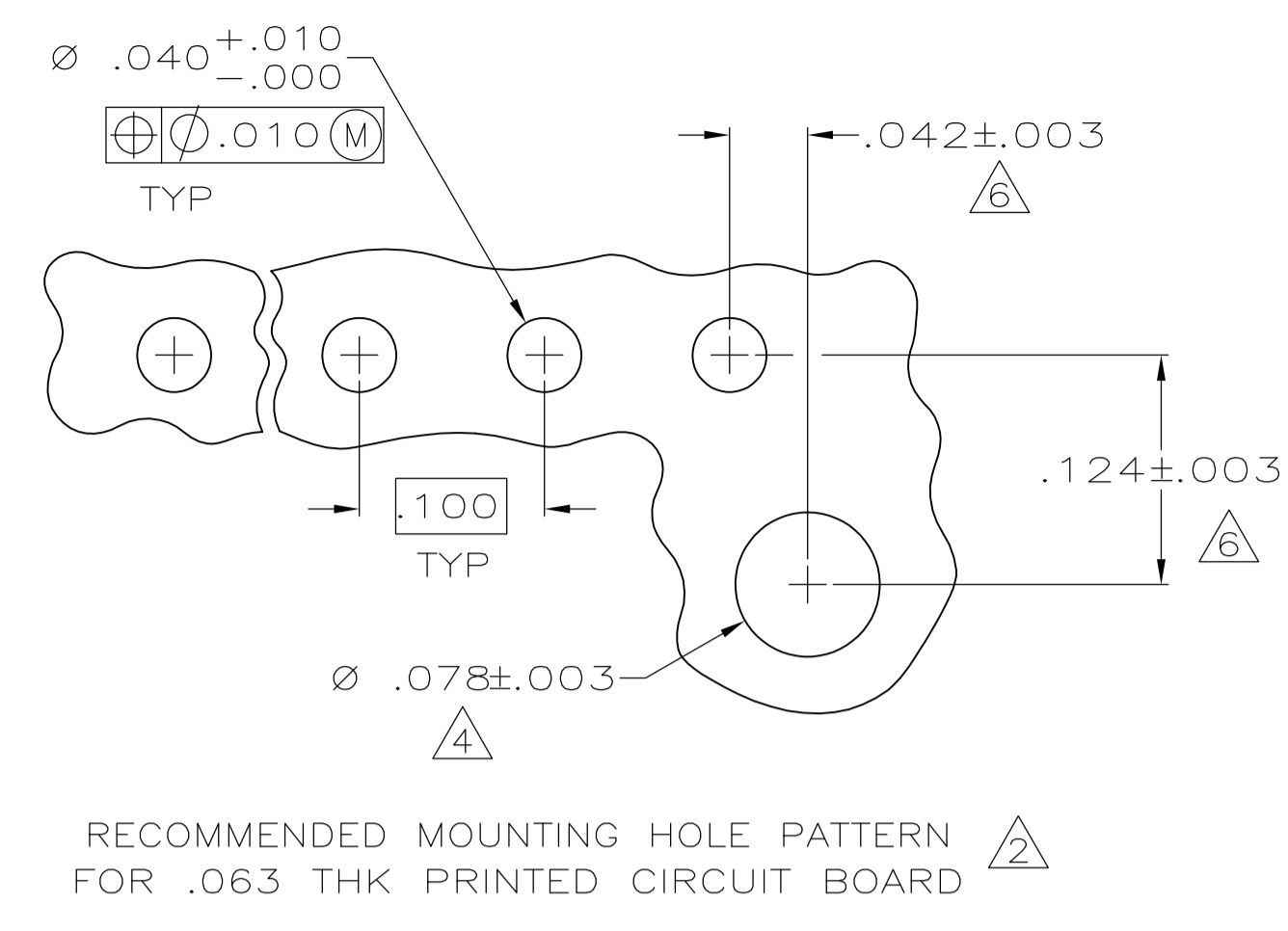
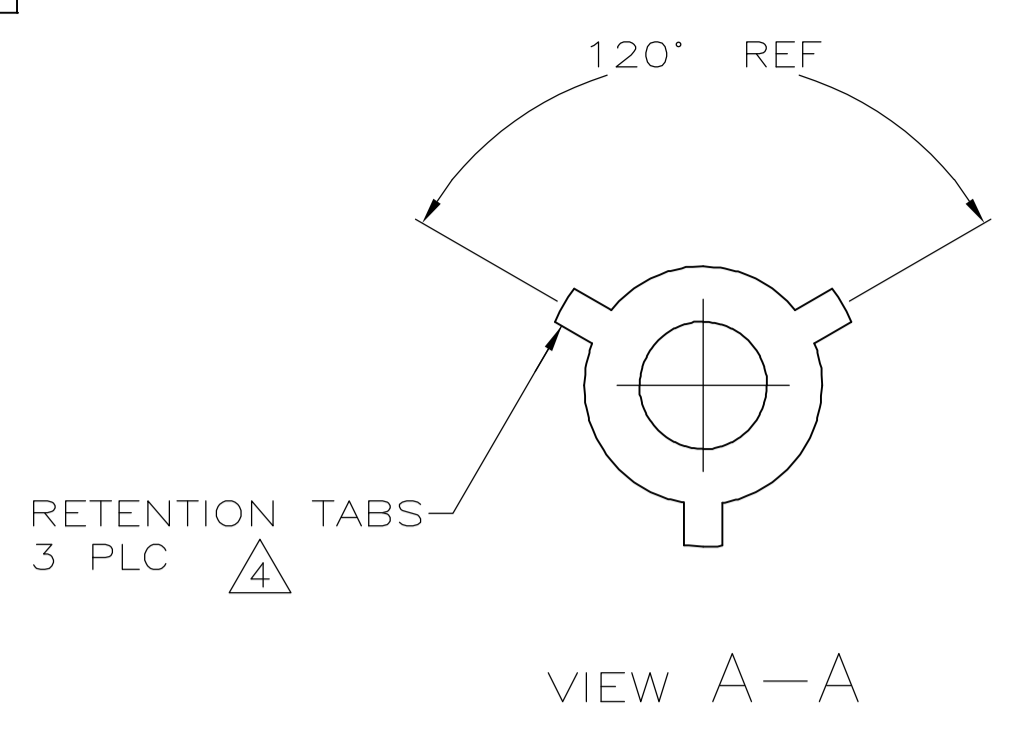
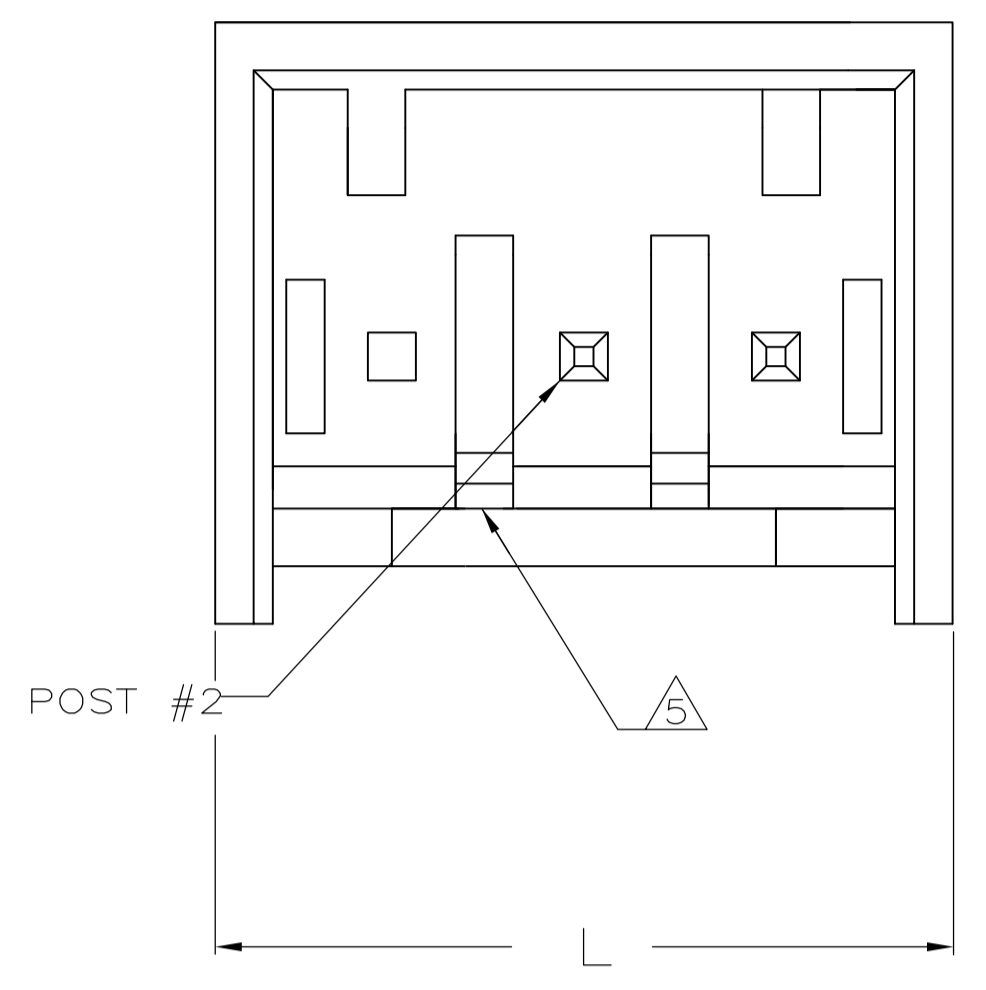

- 1 MATERIAL: HEADER- POLYESTER UL94V-0 (BLACK)
POST- COPPER ALLOY.
- 2 SOLDER SIDE OF P.C. BOARD SHOWN.
- 3. PARTS COMPLY WITH AMP SOLDERABILITY SPEC 109-11-2.
- 4 THE RETENTION TABS PROVIDE A ONE-TIME INTERFERENCE FIT IN THE .078 DIAMETER BOARD HOLE FOR HEADER ASSEMBLY RETENTION DURING SOLDERING.
- 5 LATCH DETENT FEATURE OCCURS 2 PLACES ON EACH END (MAXIMUM OF FOUR PER PART). FOR 2 THRU 5 CIRCUIT HEADERS, LATCH FEATURE OCCURS BETWEEN EACH CIRCUIT.
- 6 COORDINATE DIMENSION APPLIES FROM CENTER OF ACTUAL FEATURE.
- 7 POST: MATTE TIN-LEAD (93/7) PLATED.
- 8 UL RECOGNIZED (UR) LOGO AND CSA LOGO WILL APPEAR ON THE SIDE OF THE PART. THE AMP LOGO MAY APPEAR ON THE SIDE OR ON BOTTOM OF PART.
- 9 TWO SIDES OF TAPER, AS SHOWN, MUST BE PLATED. TYPICAL, BOTH ENDS.
- 10 TWO SIDES OF TAPER, AS SHOWN, AND TIP MAY BE UNPLATED. TYPICAL, BOTH ENDS.
- 11 POST: MATTE TIN PLATED.
- 12 OBSOLETE PARTS: OBSOLETE CIS STREAMLINING PER D.RENAUD/D.SINISI

.040	1.02	.124	3.15	-	-
.030	0.76	.107	2.72	.440	11.18
.025	0.64	.100	2.54	.410	10.41
.010	0.25	.092	2.34	.313	7.95
.005	0.13	.078	1.98	.200	5.08
.003	0.08	.063	1.6	.176	4.47
.001	0.03	.062	1.57	.140	3.56
.000	0	.042	1.07	.125	3.18
IN	MM	IN	MM	IN	MM

CONVERSION TABLE

12	SUPERSEDED	1	11	.384	9.75	3	3-1744079-3
		1	7	.384	9.75	3	4744079-3
	POST NO OMITTED	FINISH	IN	MM	NO OF POSITIONS	PART NUMBER	
			L		HEADER ASSEMBLY		

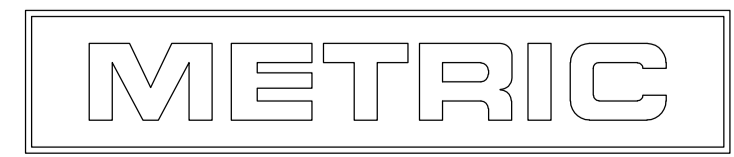

THIS DRAWING IS A CONTROLLED DOCUMENT.

DIMENSIONS: INCHES	TOLERANCES UNLESS OTHERWISE SPECIFIED:	DIN K WHITAKER 08SEP2004	TE Connectivity
0 PLC ± - 1 PLC ± - 2 PLC ± - 3 PLC ± .005 4 PLC ± - # 0.30° ANGLES ± - # 0.30°	FINISH -	CHK D BOSSI 08SEP2004 APVD D BOSSI 08SEP2004 NAME MTA-100 SHROUDED HEADER ASSEMBLY, FRICTION LOCK, STRAIGHT POST, TIN OR TIN LEAD PLATED	
MATERIAL 1		SIZE A1	CUSTOMER DRAWING SCALE 10:1 SHEET 1 OF 1 REV B

单击下面可查看定价，库存，交付和生命周期等信息

[>>TE Connectivity\(泰科\)](#)