

REVISIONS				
P.	LTN	DESCRIPTION	DATE	OWN APVD
B		REVISE PER ECO-14-015233	31MAR2015	LL SH

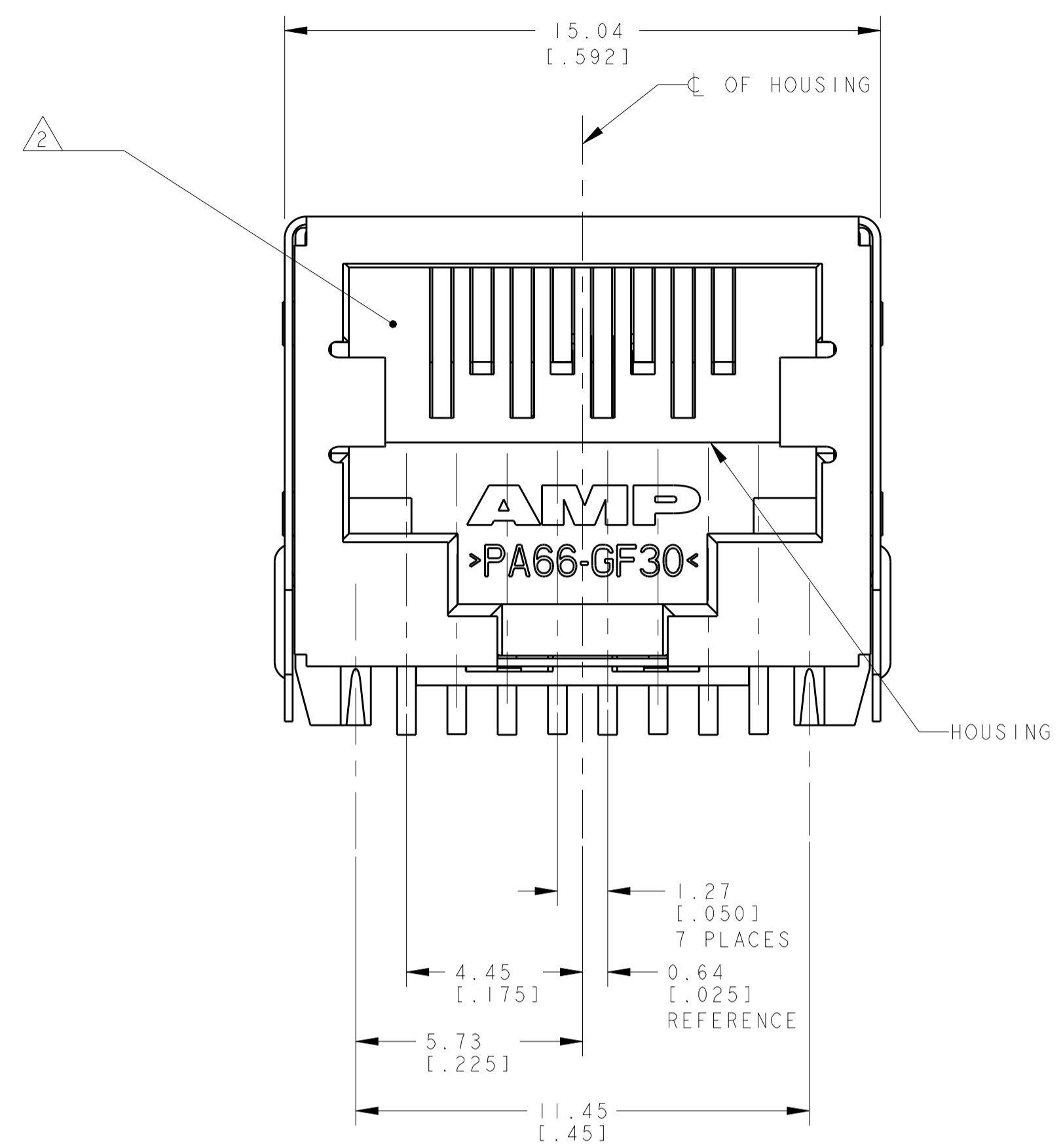

- MATERIAL: HOUSING - HIGH TEMPERATURE NYLON, BLACK, UL 94V-0, IR REFLOW SOLDERING PROCESS COMPATIBLE
TERMINALS - 0.25[.01] THICK PHOSPHOR BRONZE PLATED WITH 3.81µm[.000150] MINIMUM THICK MATTE TIN IN SOLDER AREA, 1.27µm[.000050] MINIMUM GOLD IN LOCALIZED PLATE AREA. ENTIRE TERMINAL PLATED WITH 1.27µm[.000050] MINIMUM THICK NICKEL.
SHIELD - 0.11[.0039] MIN THICK COPPER ZINC ALLOY, PREPLATED WITH 2.0-4.0µm[.000079-.000157] THICK BRIGHT TIN OVER 1.27 µm[.00010] MIN THICK NICKEL
- JACK CAVITY CONFORMS TO FCC RULES AND REGULATIONS PART 68, SUBPART F.
- THIS DIMENSION REPRESENTS THE TOTAL HEIGHT OF THE CONNECTOR FROM THE TOP OF THE PC BOARD.
- PACKAGED 66 ASSEMBLIES PER PVC TRAY, 396 PER BOX.
- DIELECTRIC WITHSTANDING VOLTAGE BETWEEN SHIELD AND TERMINAL IS 1500 VAC
- MANUFACTURING DATE CODE:
ORIENTED AND LOCATED APPROXIMATELY AS SHOWN. LASER PRINTING. TEXT HEIGHT APPROXIMATELY 2MM.
FIRST 2 DIGITS = LAST 2 DIGITS OF YEAR
NEXT 2 DIGITS = MANUFACTURING WORK WEEK
LAST DIGIT = DAY OF WEEK WITH SUNDAY = 1

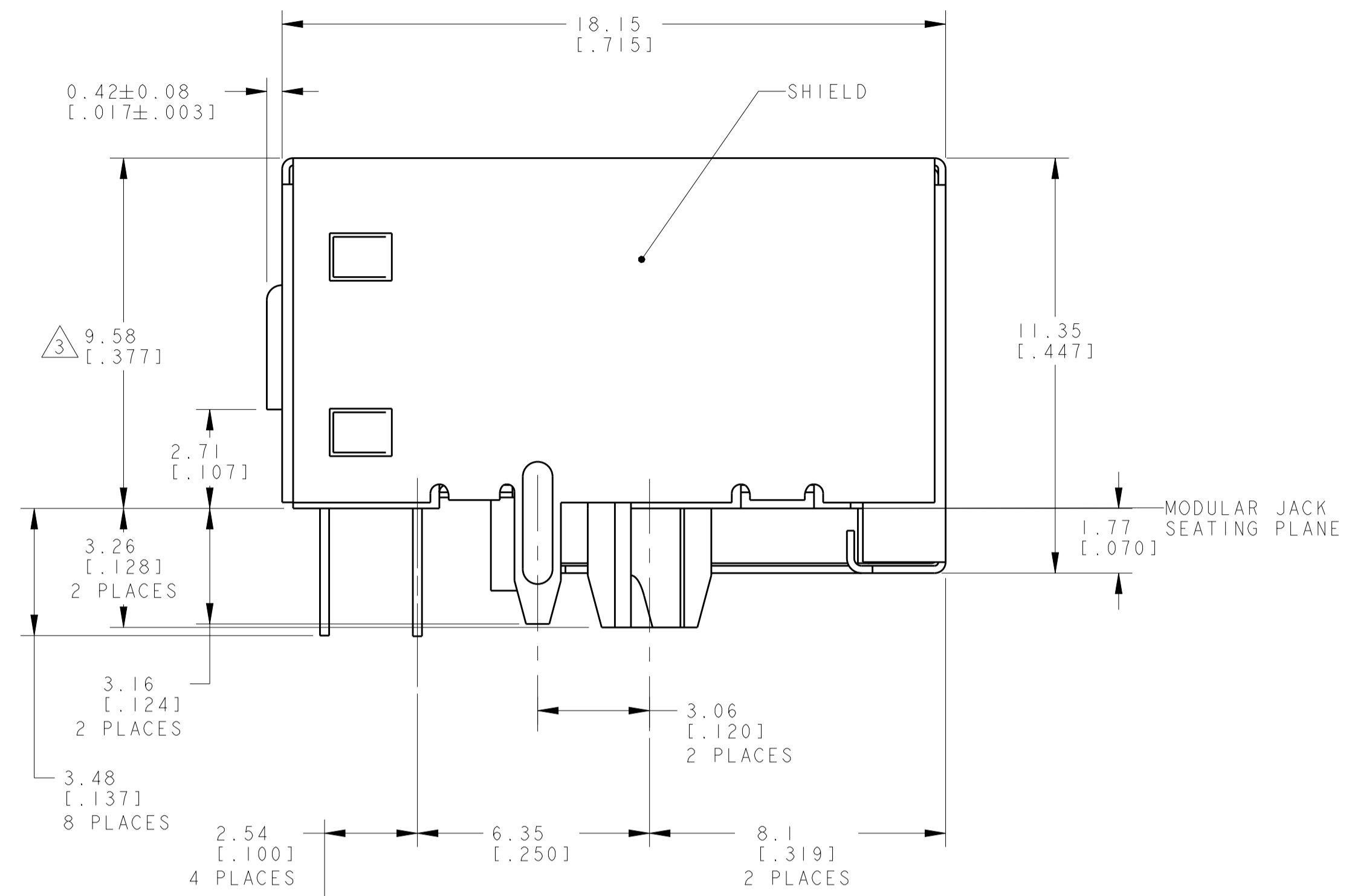
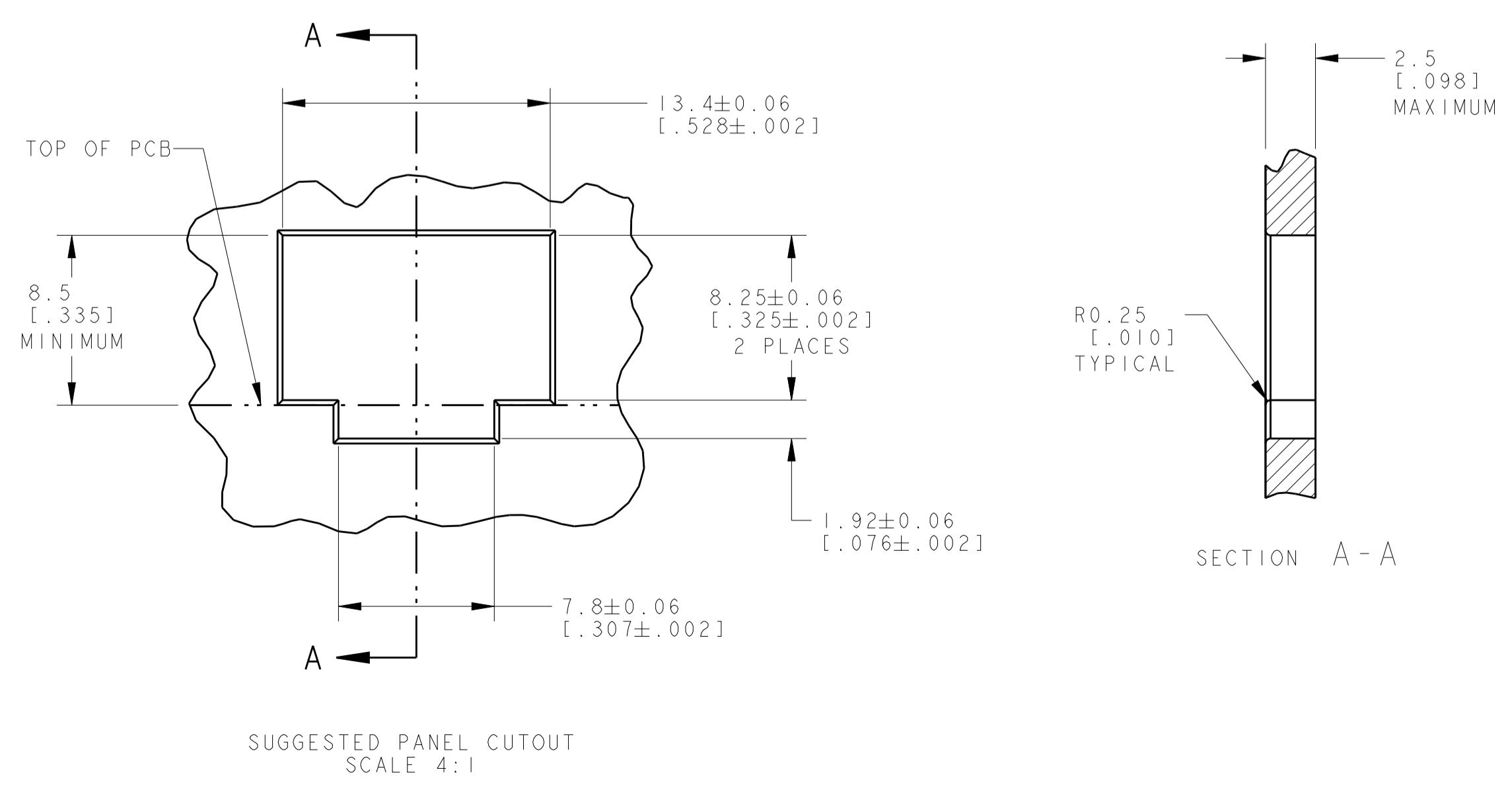
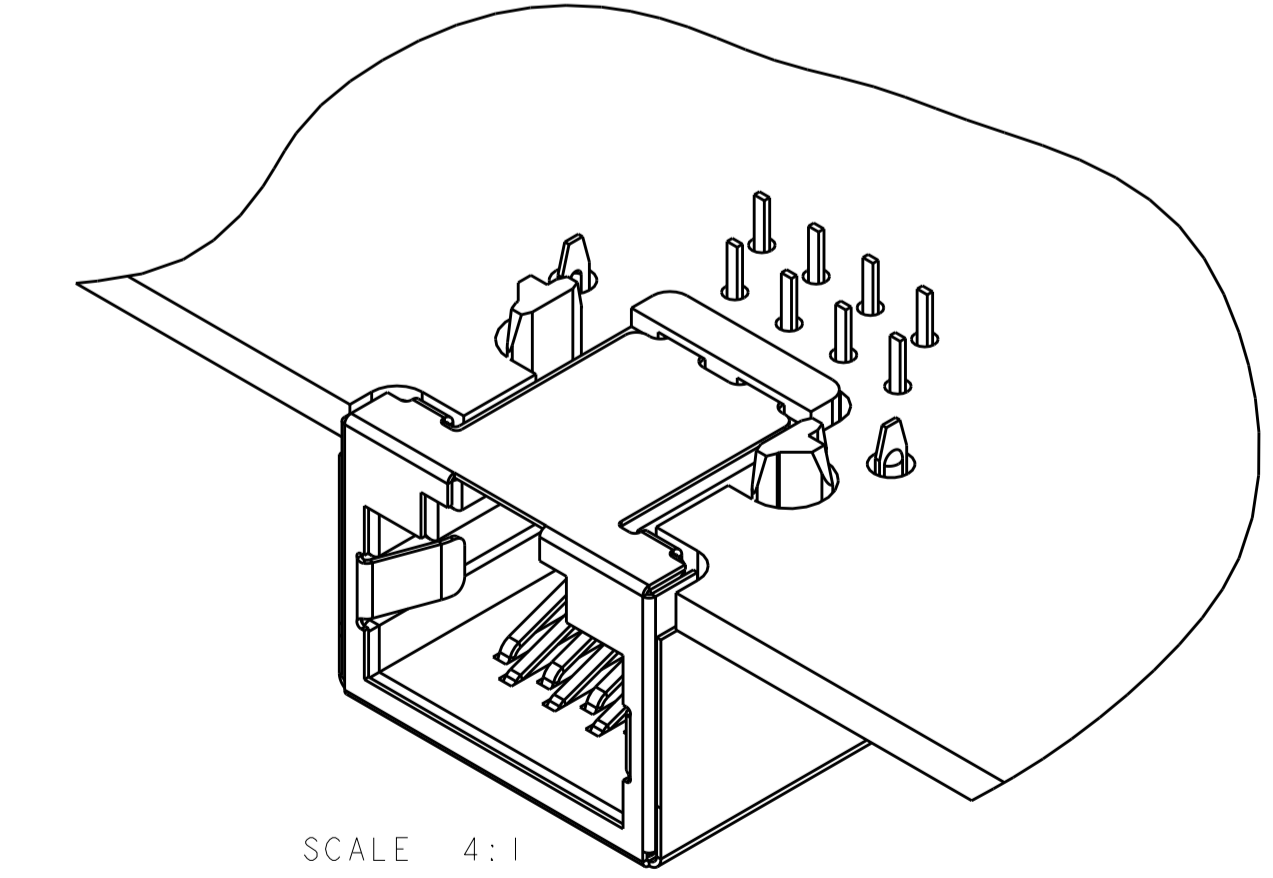
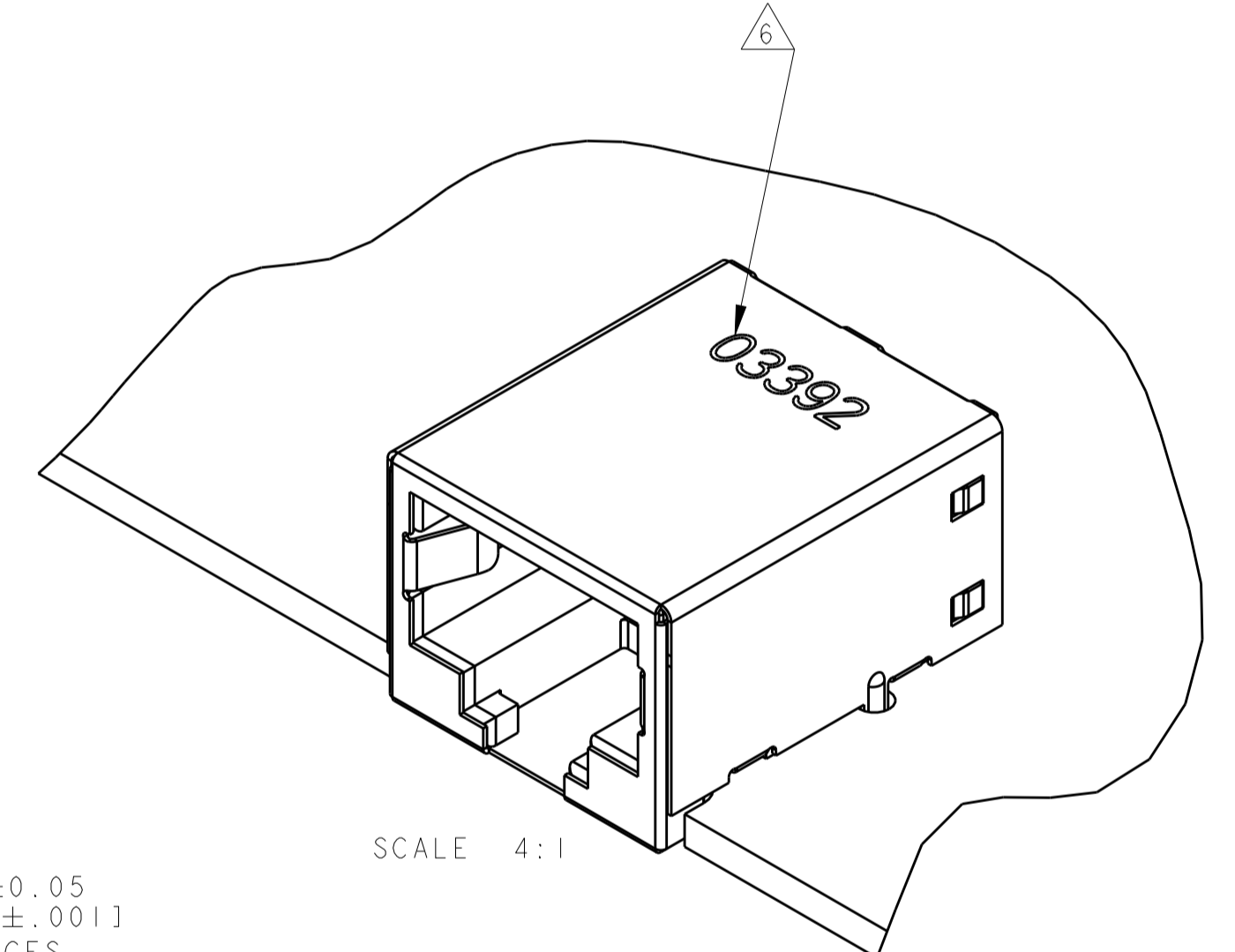
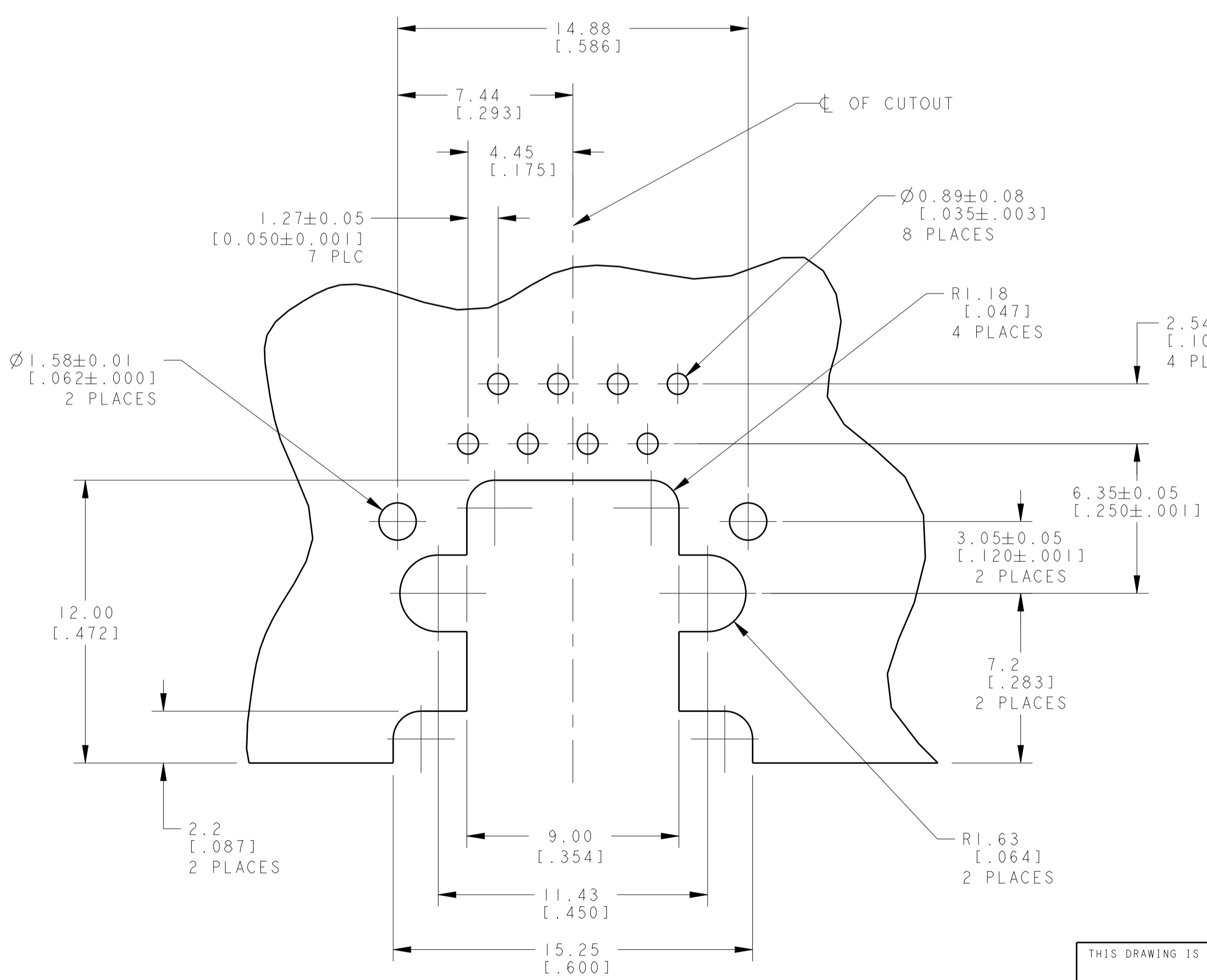
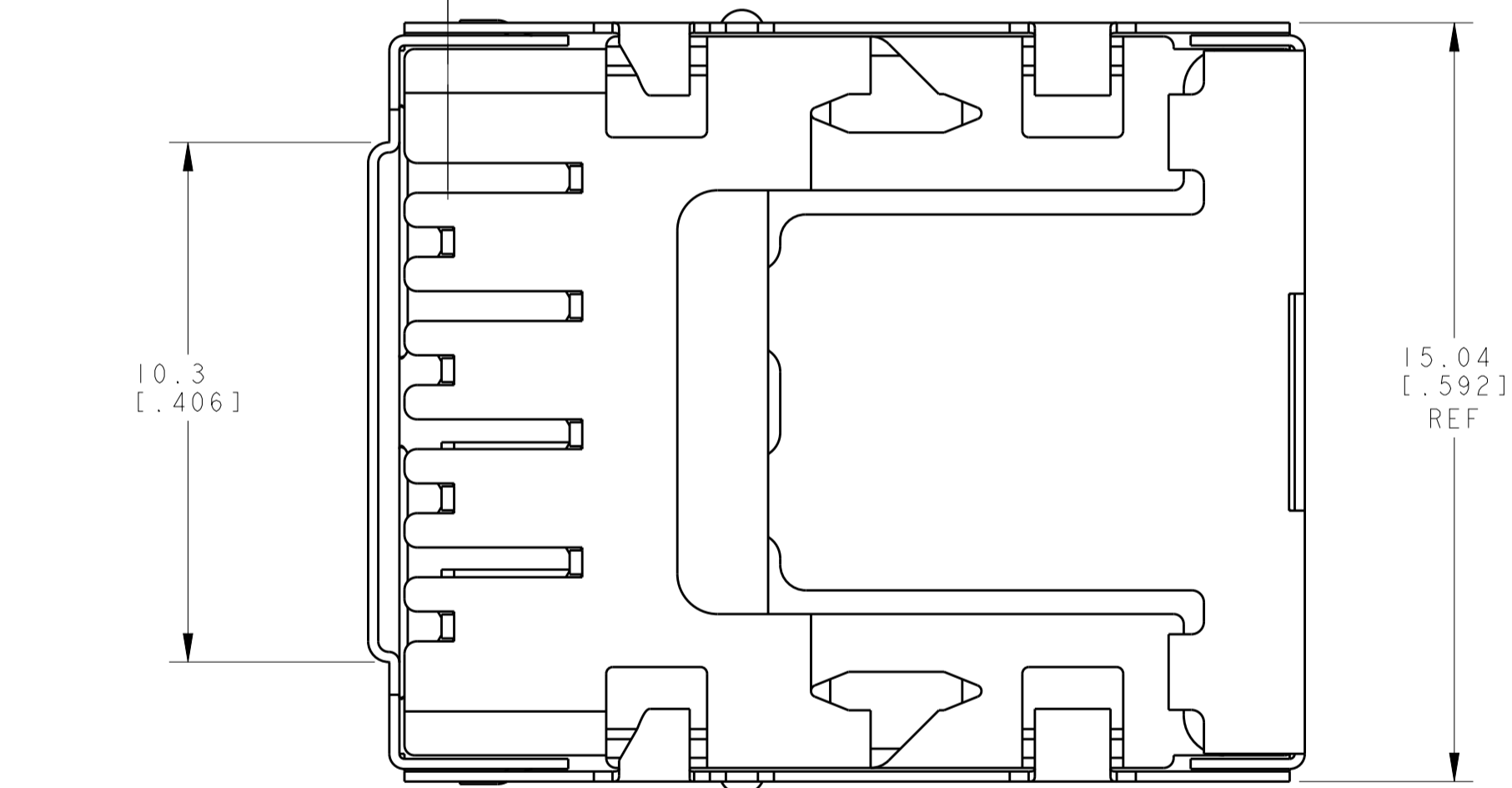

SUGGESTED PRINTED CIRCUIT BOARD LAYOUT COMPONENT SIDE SCALE 6:1

1888543-2
PART NUMBER

THIS DRAWING IS A CONTROLLED DOCUMENT.		OWN: J. AHERON / J. A. MATYR 07JUNE2006	TE Connectivity
DIMENSIONS: mm [INCHES]		CHK: J. WESTMAN 07JUNE2006	
TOLERANCES UNLESS OTHERWISE SPECIFIED:		APVD: S. FELICKINGER 07JUNE2006	NAME: MODULAR JACK ASSEMBLY, 8 POSITION, SHIELDED, 10mm WITHOUT PANEL TABS PRODUCT SPEC: 108-1163 APPLICATION SPEC: 114-2048
0 PLC ± 1 PLC ± 2 PLC ±0.131(.005) 3 PLC ± 4 PLC ± ANGLES ±		WEIGHT: 3.49 grams CUSTOMER DRAWING	
MATERIAL: SEE NOTE 1		FINISH: SEE NOTE 1	SIZE: A1 CAGE CODE: 1888543 SCALE: 4:1 SHEET 1 OF 1 REV B

单击下面可查看定价，库存，交付和生命周期等信息

[>>TE Connectivity\(泰科\)](#)