



MULTI FUNCTION PUCK ANTENNA

LOW PROFILE ANTENNA

This antenna range is designed to decrease the applied cost of M2M and IoT applications by offering a robust low profile antenna with an extremely compact envelope. Ideal for situations where a robust solution is required. The antenna covers 698-960/1710-3800MHz and optional 2.4/5.9GHz WLAN and optional GPS/GNSS with a 26dB LNA.

At < 22mm height the antenna is extremely discreet and ideal for low clearance deployment locations. The antenna is suitable for non conductive panels.

Technical Drawing

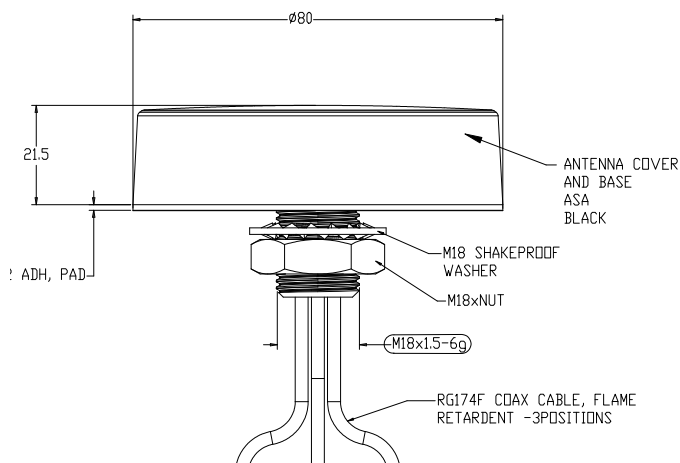

Partnumber	Cell	WLAN	GNSS	Length	Connector
2363696-1	Y	Y	Y	3m	SMA
2363696-2	Y	Y	Y	3m	Fakra
2363696-3	Y	Y	Y	1m	Fakra
2363696-4	Y	Y	Y	1m	SMA
1-2363696-1	Y	Y	N	3m	SMA
1-2363696-2	Y	Y	N	3m	Fakra
1-2363696-3	Y	Y	N	1m	Fakra
1-2363696-4	Y	Y	N	1m	SMA
2-2363696-1	Y	N	N	3m	SMA
2-2363696-2	Y	N	N	3m	Fakra
2-2363696-3	Y	N	N	1m	Fakra
2-2363696-4	Y	N	N	1m	SMA

MULTI FUNCTION PUCK ANTENNA

LOW PROFILE ANTENNA FOR DAS NETWORKS

Electrical Data		2363696-1	2363696-2	2363696-3	2363696-4
Frequency Range (MHz)	Element 1	698-960 / 1710-3800			
	Element 2	2400-2485 / 4900-6000			
Operational band		2G/3G/4G/5G, WLAN/Wi-Fi, GPS			
Peak Gain	Element 1: 698-960MHz	0dBi			
	Element 1: 1710-3800MHz	2dBi			
	Element 2: 2.4GHz	2dBi			
	Element 2: 5.0GHz	4dBi			
Typical VSWR		< 2.5:1			
Polarisation		Vertical			
Pattern		Omni-Directional			
Impedance		50Ω			
Max Input Power (W)		20			
GPS/GNSS Data					
Frequency Range (MHz)		1562-1612 MHz			
LNA Gain (dB)		26dB			
Typical Current (mA)		15			
Typical Voltage		3-5 VDC			
Mechanical Data					
Dimensions (mm)	Height (mm)	22.5 (0.88")			
	Diameter (mm)	80 (3.14")			
Operating Temp (°C)		-40 to +85°C (-40 to 185°F)			
Material		ASA			
Colour		Black			
Ingress Protection		IP66 / IK07			
Mounting Data					
Fixing		Panel mount - 19mm (3/4")			
Cable Data					
Cable 1: Cellular	Cable Type	RG174 (meets UN ECE 118)			
	Diameter (mm)	2.8 (0.11")			
	Length (m)	3 (10')		1 (3' 3")	
	Termination	SMA plug	FAKRA D Jack	FAKRA D Jack	SMA plug
Cable 2: Wi-Fi	Cable Type	RG174 (meets UN ECE 118)			
	Diameter (mm)	2.8 (0.11")			
	Length (m)	3 (10')		1 (3' 3")	
	Termination	SMA Rev Pol	FAKRA I Jack	FAKRA I Jack	SMA Rev Pol
Cable 3: GPS/GNSS	Cable Type	RG174 (meets UN ECE 118)			
	Diameter (mm)	2.8 (0.11")			
	Length (m)	3 (10')		1 (3' 3")	
	Termination	SMA plug	Fakra C jack	Fakra C Jack	SMA plug

Peak gain modelled in CST Microwave Studio and does not include cable attenuation

MULTI FUNCTION PUCK ANTENNA

LOW PROFILE ANTENNA FOR DAS NETWORKS

Electrical Data		1-2363696-1	1-2363696-2	1-2363696-3	1-2363696-4
Frequency Range (MHz)	Element 1	698-960 / 1710-3800			
	Element 2	2400-2485 / 4900-6000			
Operational band		2G/3G/4G/5G, WLAN/Wi-Fi			
Peak Gain	Element 1: 698-960MHz	0dBi			
	Element 1: 1710-3800MHz	2dBi			
	Element 2: 2.4GHz	2dBi			
	Element 2: 5.0GHz	4dBi			
Typical		< 2.5:1			
Polarisation		Vertical			
Pattern		Omni-Directional			
Impedance		50Ω			
Max Input Power (W)		20			
Mechanical Data					
Dimensions (mm)	Height (mm)	22.5 (0.88")			
	Diameter (mm)	80 (3.14")			
Operating Temp (°C)		-40 to +85°C (-40 to 185°F)			
Material		ASA			
Colour		Black			
Ingress protection		IP66/IK07			
Mounting Data					
Fixing		Panel mount - 19mm (3/4")			
Cable Data					
Cable 1: Cellular	Cable Type	RG174 (meets UN ECE 118)			
	Diameter (mm)	2.8 (0.11")			
	Length (m)	3 (10')		1 (3' 3")	
	Termination	SMA plug	FAKRA D Jack	FAKRA D Jack	SMA plug
Cable 2: Wi-Fi	Cable Type	RG174 (meets UN ECE 118)			
	Diameter (mm)	2.8 (0.11")			
	Length (m)	3 (10')		1 (3' 3")	
	Termination	SMA Rev Pol	FAKRA I Jack	FAKRA I Jack	SMA Rev Pol

Peak gain modelled in CST Microwave Studio and does not include cable attenuation

MULTI FUNCTION PUCK ANTENNA

LOW PROFILE ANTENNA FOR DAS NETWORKS

Electrical Data		2-2363696-1	2-2363696-2	2-2363696-3	2-2363696-4
Frequency Range (MHz)		698-960 / 1710-3800			
Operational Band		2G/3G/4G/5G			
Peak Gain	Element 1: 698-960MHz	0dBi			
	Element 1: 1710-3800MHz	2dBi			
Typical		< 2.5:1			
Polarisation		Vertical			
Pattern		Omni-Directional			
Impedance		50Ω			
Max Input Power (W)		20			
Mechanical Data					
Dimensions (mm)	Height (mm)	22.5 (0.88")			
	Diameter (mm)	80 (3.14")			
Operating Temp (°C)		-40 to +85°C (-40 to 185°F)			
Material		ASA			
Colour		Black			
Ingress Protection		IP66/IK07			
Mounting Data					
Fixing		Panel mount - 19mm (3/4")			
Cable Data					
Cable 1: Cellular	Cable Type	RG174 (meets UN ECE 118)			
	Diameter (mm)	2.8 (0.11")			
	Length (m)	3 (10')		1 (3' 3")	
	Termination	SMA plug	FAKRA D Jack	FAKRA D Jack	SMA plug

Typical VSWR - Element 1*

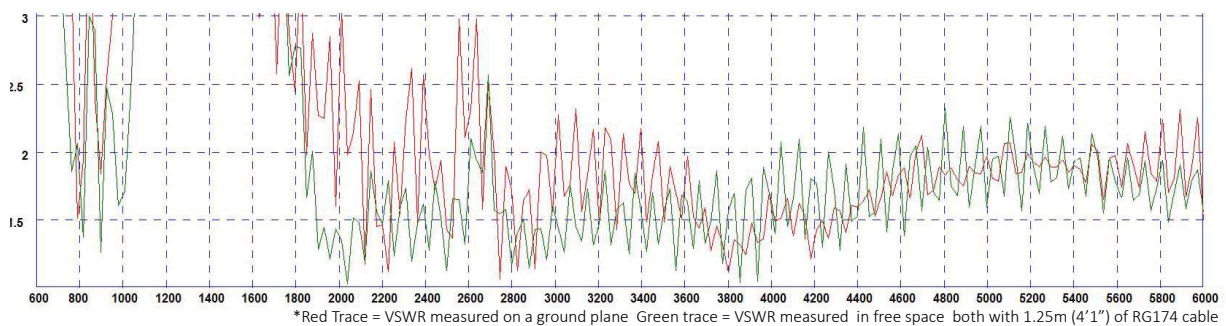

Typical VSWR - Element 2*

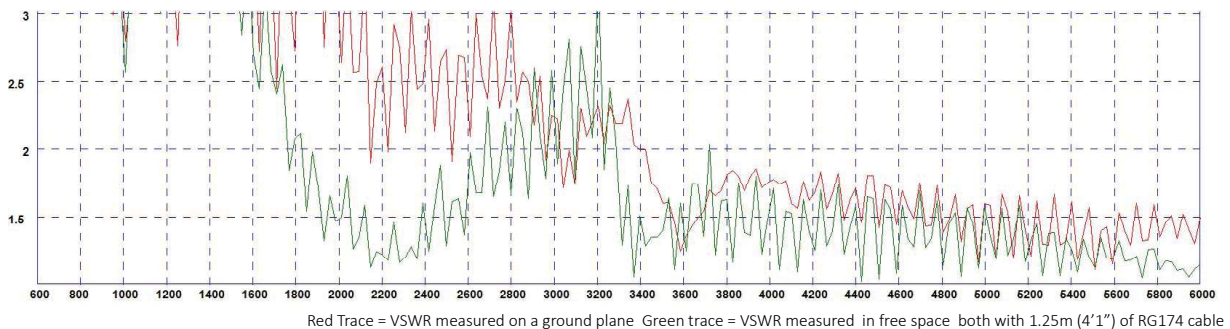

3D Patterns Cell

Typical 3D Pattern 700MHz

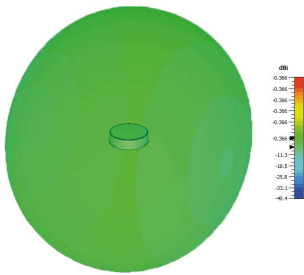

Typical 3D Pattern 800MHz

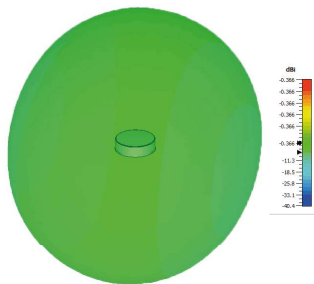

Typical 3D Pattern 900MHz

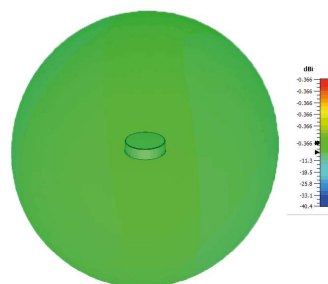

Typical 3D Pattern 1800MHz

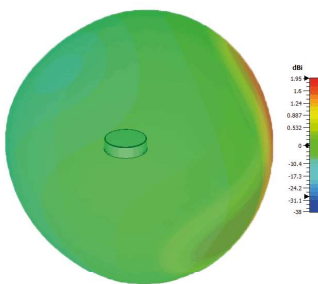

Typical 3D Pattern 2000MHz

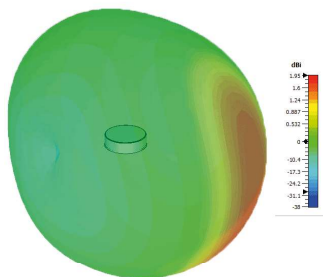

Typical 3D Pattern 2600MHz

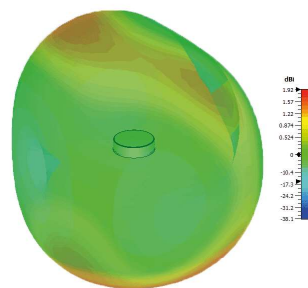

Typical 3D Pattern 3600MHz

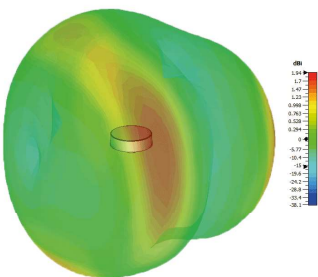

3D Patterns Wi-Fi

Typical 3D Pattern 2450MHz

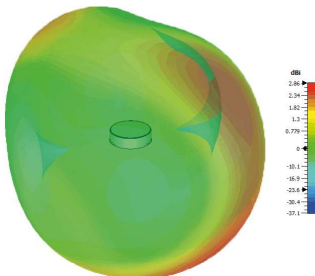

Typical 3D Pattern 5400MHz

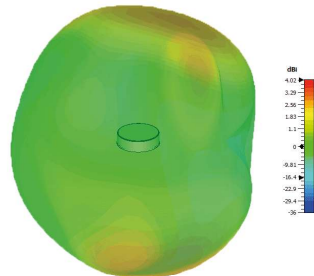

单击下面可查看定价，库存，交付和生命周期等信息

[>>TE Connectivity\(泰科\)](#)