

© - TE Connectivity. All Rights Reserved.

REVISIONS					
P	LTR	DESCRIPTION	DATE	DWN	APVD
	C	REVISED PER ECO-19-009164	24JUN2020	KG	DR

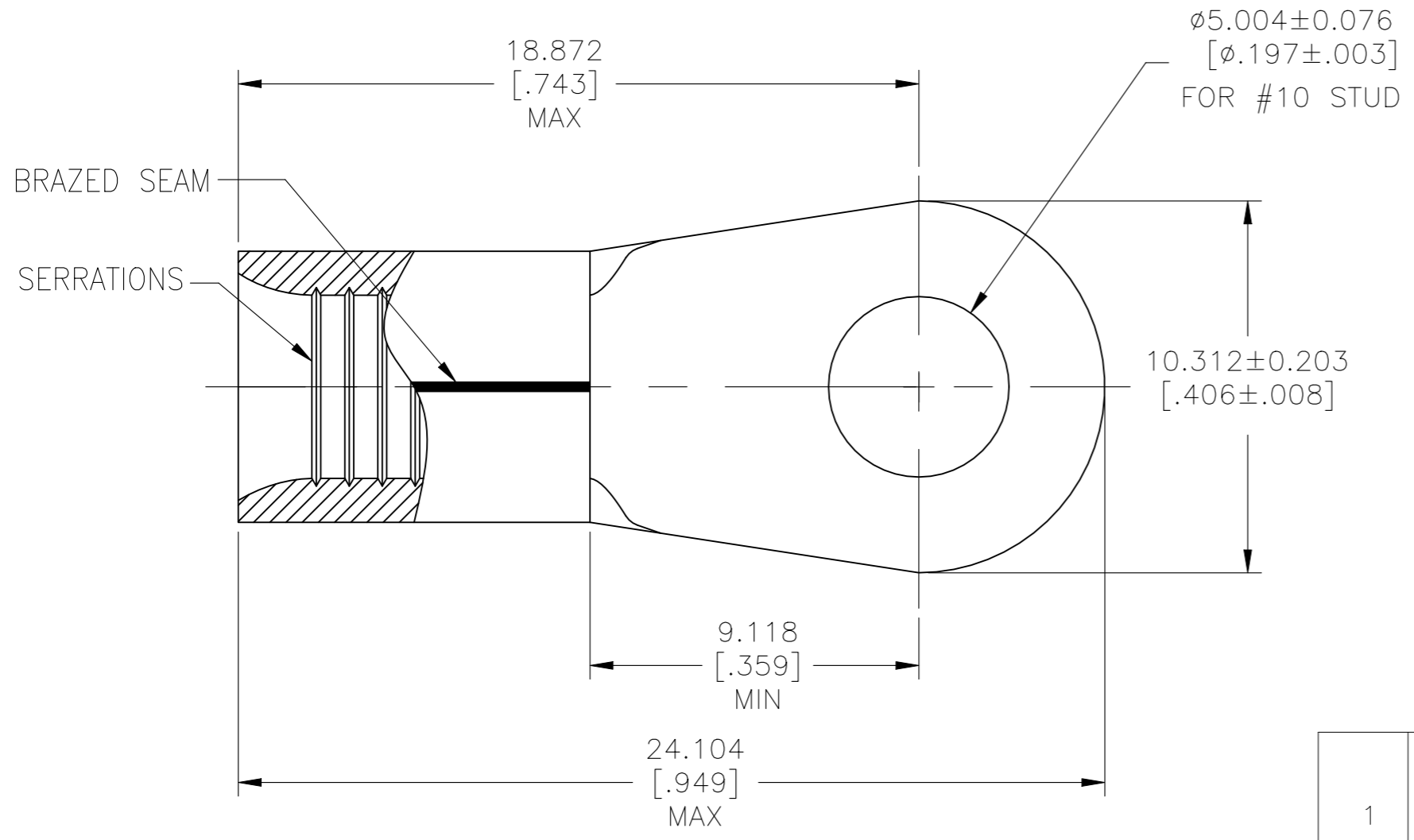

- 1 WIRE RANGE IS FOR 8 AWG. STANDARD WIRE CROSS SECTIONAL AREA RANGE: 13,100-20,800 CMA, STRANDED WIRE
 - 2 TERMINAL BODY MATERIAL THK IS 1.219 ± 0.076 [.048 ± .003]
 - 3 RECOMMENDED OPERATING TEMP -55°C [131°F] TO $+200^{\circ}\text{C}$ [392°F] FOR HEAT SHRINK TUBING
 - 4 HEAT SHRINK TUBING SHELF LIFE OF 18 MONTHS FROM DATE CODE ON LABEL
- △ 5 TERMINAL BODY PRODUCT SPECIFICATION 108-32046 APPLICATION SPECIFICATION 114-2162

1	8-1190141-0	HIGH AND LOW TEMPERATURE CROSS LINKED FLUOROPOLYMER HEAT SHRINK TUBING 9.53 [.375] MIN ID X 25.400 ± 2.032 [1.000 ± .080] RT555-3/8-0-SP
1	323165	TERMINAL BODY: COPPER PER ASTM B152 ANNEALED FINISH: NICKEL PLATE 0.00762 [.000300] MIN EXT THK PER SAE AMS QQ-N-290
-1	PART NO	DESCRIPTION

THIS DRAWING IS A CONTROLLED DOCUMENT.		DWN JR RUTH 30JAN04	STE TE Connectivity			
DIMENSIONS: mm [INCHES]		CHK MJ SPICER 08APR04				
TOLERANCES UNLESS OTHERWISE SPECIFIED:		APVD MJ SPICER 08APR04	NAME			
0 PLC ± -		PRODUCT SPEC	HEAT RESISTANT TERMINAL KIT WIRE SIZE: 8 AWG			
1 PLC ± -		APPLICATION SPEC				
2 PLC ± -		WEIGHT	SIZE	CAGE CODE	DRAWING NO	RESTRICTED TO
3 PLC ± 0.127 [.005]			A3	00779	C-696633	
4 PLC ± -			CUSTOMER DRAWING			
ANGLES ± 1°			SCALE	SHEET	REV	
MATERIAL SEE TABLE		FINISH SEE TABLE	1:1	1 OF 1	C	

单击下面可查看定价，库存，交付和生命周期等信息

[>>TE Connectivity\(泰科\)](#)