

NOTES:

- THIS INSERT IS DESIGNED FOR USE IN RAYCHEM CONNECTOR HOUSING MTC100-JH2-XXX. (SEE RAYCHEM INFORMATION DRAWING D-659-0097 AND HOUSING SPECIFICATION CONTROL DRAWINGS FOR FURTHER DETAILS).
- PART DESCRIBED HEREON IS SUPPLIED AS SHOWN. IF CONTACTS, SEALING PLUGS, AND TOOLS ARE DESIRED, THE FOLLOWING MODIFICATION NUMBER IS TO BE ADDED TO THE PART NUMBER ON THE KIT PACKAGING LABEL ONLY:

MOD. NO.	DESCRIPTION
022	WITH CONTACTS AND SEALING PLUGS
023	WITH CONTACTS, SEALING PLUGS AND TOOL

REFERENCE RAYCHEM INFORMATION DRAWING D-659-0097 FOR CRIMP TOOLS OR ADDITIONAL CONTACTS, SEALING PLUGS OR TOOLS.

- GROMMET DESIGNED TO SEAL ON WIRES HAVING AN INSULATION DIAMETER OF 0.030 TO 0.065.
- PERFORMANCE:
THIS PRODUCT IS DESIGNED TO MEET THE APPLICABLE REQUIREMENTS OF RAYCHEM SPECIFICATION C-6115.

- MATERIALS:
 - A) PLASTIC INSERT HIGH GRADE POLYARYLENE THERMOPLASTIC
 - B) GROMMET FLUOROSILICONE PER MIL-R-25988
 - C) RETENTION CLIPS (20) BERYLLIUM COPPER 172 PER QQ-C-533
(INSIDE PLASTIC INSERT)

△ NUMBER ONE (1) CAVITIES ARE MARKED IN CONTRASTING COLOR. ROWS "A" AND "B" ARE AN INTEGRAL PART OF THE INSERT. ROWS "A" AND "B" ARE IDENTIFIED ON THE SIDE OF THE INSERT AS "A1" AND "B1". "B" SIDE MARKING OPTIONAL.

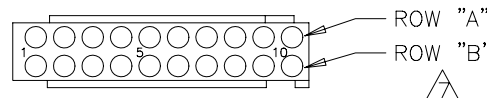
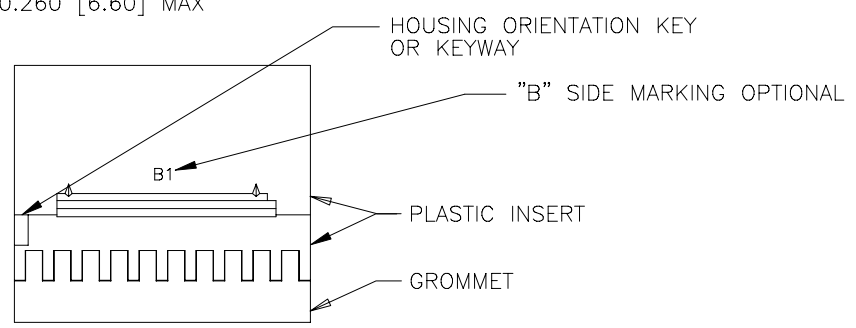
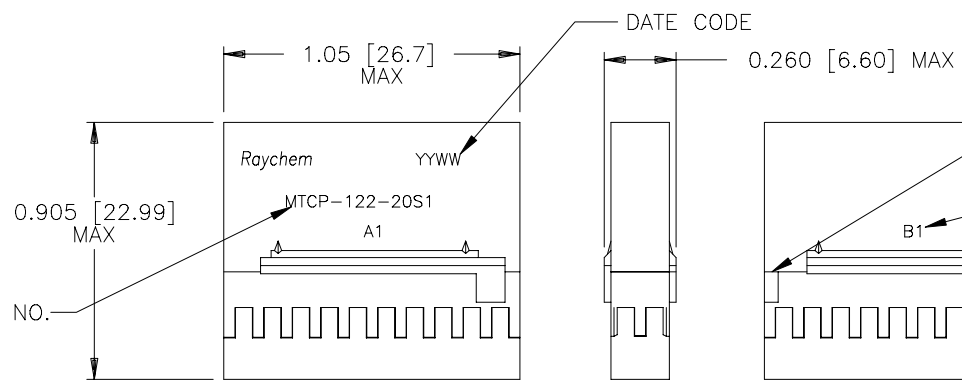
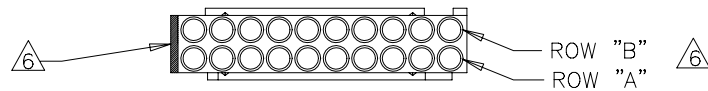
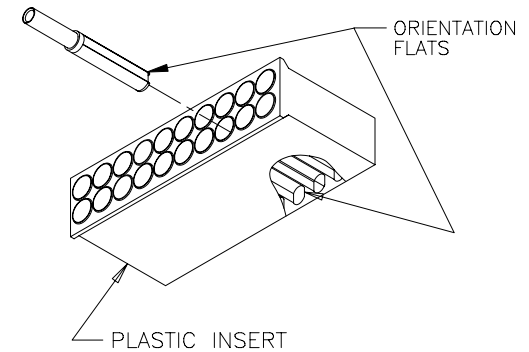

REVISIONS			
LTR	DESCRIPTION	DATE	APPROVED
G	REVISED PER ECN T-19724	95JAN04	R.H.
H	REVISED PER ECN T-20815	21MAY96	HIGGY
J	REVISED PER ECN T-22648	12AUG99	T.SEATON

SPECIFICATION CONTROL DRAWING

UNLESS OTHERWISE SPECIFIED DIMENSIONS ARE IN INCHES. METRIC DIMENSIONS ARE IN BRACKETS. DECIMALS .XXX ± .XX ± N/A } mm } ANGLES .X ±	DRAWN	HAWKINGS	87 DEC 02	Raychem RAYCHEM CORPORATION 300 CONSTITUTION DRIVE MENLO PARK, CALIFORNIA 94025		
	CHECKED			TITLE INSERT, SOCKET, PRIMARY, 20 CAVITY, SIZE 22-20 REMOVABLE CONTACT 2" CONNECTOR MTC100 SERIES		
	APPROVED	G.F.BLAIR	88 MAR 16	SIZE	CODE IDENT. NO.	DWG. NO.
	APPROVED	J.CAMERON	88 MAR 16	A	06090	MTCP-122-20S1
WEIGHT	2.88 g MAX.		THIRD ANGLE PROJECTION	DO NOT SCALE THIS DRAWING		REV J

**If this document is printed it becomes uncontrolled.
Check with the web for latest revision.**

DWG. NO. MTCP-122-20S1 SHEET 1

单击下面可查看定价，库存，交付和生命周期等信息

[>>TE Connectivity\(泰科\)](#)