

THIS DRAWING IS UNPUBLISHED. RELEASED FOR PUBLICATION APRIL, 2004.

© COPYRIGHT 2004 By - ALL RIGHTS RESERVED.

LOC	DIST	REVISIONS					
E	B	P	LTR	DESCRIPTION	DATE	DWN	APVD
			A1	REVISED PER ECO-11-005033	01APR11	RK	HMR

NOTES:

- 1 SINGLE PACK IN ACCORDANCE WITH SPEC 107-3275
- 2 100 TRAY PACK IN ACCORDANCE WITH SPEC 107-3275
- 3 0.08µm Au PLATING OVER 1.27µm Ni PLATING
- 4 0.08µm Au PLATING OVER 1.27µm Ni PLATING OVER 0.76µm Cu PLATING
- 5 0.76µm Au PLATING OVER 1.27µm Ni PLATING OVER 0.76µm Cu PLATING
- 6 PASSIVATED
- 7 WHITE BRONZE PLATING
- 8 FOR TECHNICAL DATA REFER TO YOUR LOCAL TE CONNECTIVITY SALES OFFICE
- 9 ALL DIMENSIONS ARE NOMINAL FOR REFERENCE ONLY UNLESS OTHERWISE STATED

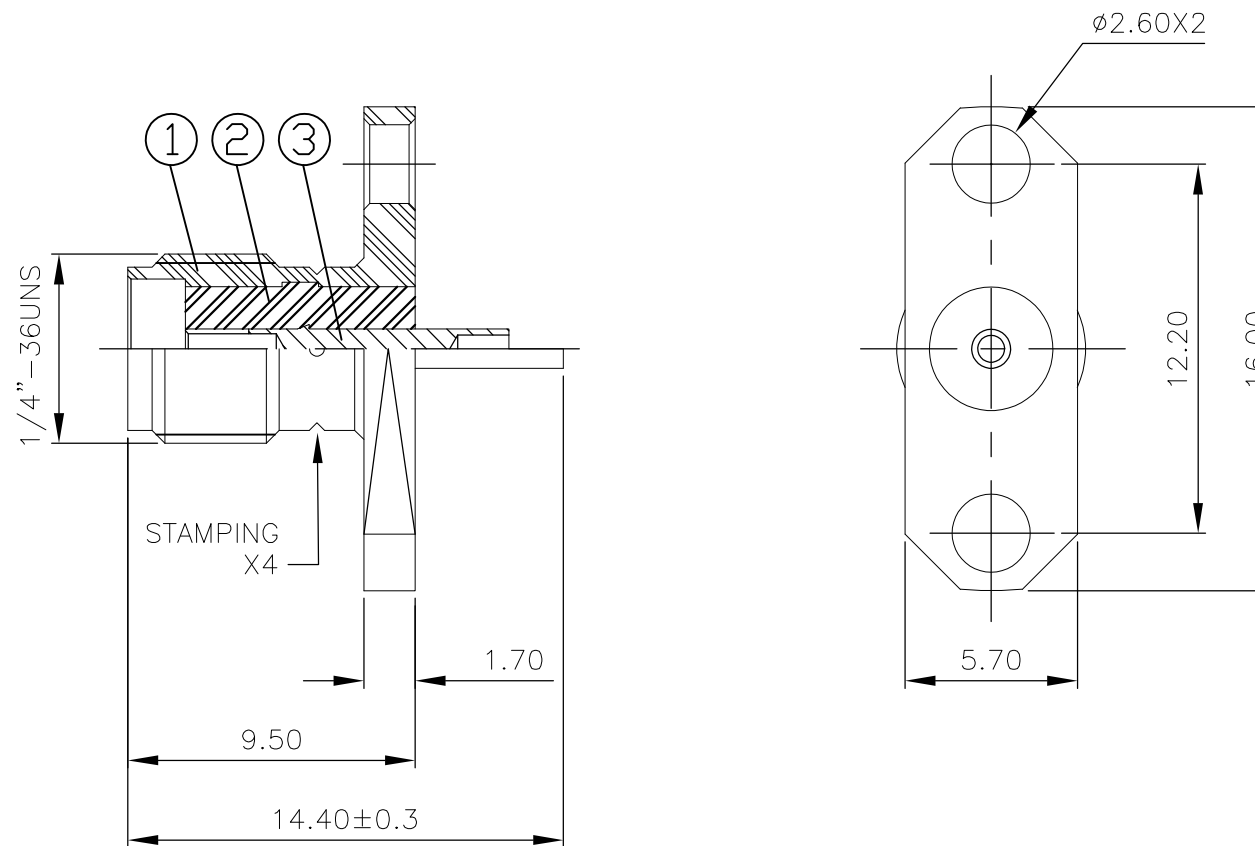

1	1	1	1	1	1	1	1	BERYLLIUM COPPER	5	CENTER SOCKET	3
1	1	1	1	1	1	1	1	PTFE		INSULATOR	2
1	1	-	-	-	-	-	-	BRASS	7	BODY	1
-	-	1	1	-	-	-	-	BRASS	4	BODY	1
-	-	-	-	1	1	-	-	STAINLESS STEEL	6	BODY	1
-	-	-	-	-	-	1	1	STAINLESS STEEL	3	BODY	1
4--1	4--0	3--1	3--0	2--1	2--0	1--1	1--0	MATERIAL		DESCRIPTION	ITEM
2	1	2	1	2	1	2	1				
QUANTITY PER ASSY								PARTS LIST			

THIS DRAWING IS A CONTROLLED DOCUMENT.		DWN R.SMITH 12FEB04	 TE Connectivity		
DIMENSIONS: mm		CHK S.PARLOW 12FEB04			
TOLERANCES UNLESS OTHERWISE SPECIFIED:		APVD F.WHEELER-KING 12FEB04	NAME SMA STRAIGHT PANEL SOCKET RECEPTACLE 2 HOLE FLANGE SOLDER SPILL		
0 PLC ± -		PRODUCT SPEC 108-3460	SIZE A3		
1 PLC ± -		APPLICATION SPEC	CAGE CODE 00779		
2 PLC ± -		WEIGHT -	DRAWING NO C-1478963		
3 PLC ± -			RESTRICTED TO -		
4 PLC ± -			SCALE 1:1		
ANGLES ± -			SHEET 1 OF 1		
FINISH -			REV A1		
MATERIAL SEE TABLE		CUSTOMER DRAWING			

单击下面可查看定价，库存，交付和生命周期等信息

[>>TE Connectivity\(泰科\)](#)