

THIS DRAWING IS UNPUBLISHED. RELEASED FOR PUBLICATION, 19 .  
 © COPYRIGHT 19 BY AMP INCORPORATED. ALL INTERNATIONAL RIGHTS RESERVED.

LOC		DIST		REVISIONS				DATE	APPD
ZONE	LTR	DESCRIPTION	DATE	APPD					
G	14	P	F	D	REVISED PER 0720-0230-93	2/25/94	OK	DAP	

**METRIC**  
 DIMENSIONS LISTED IN mm [ INCHES ]

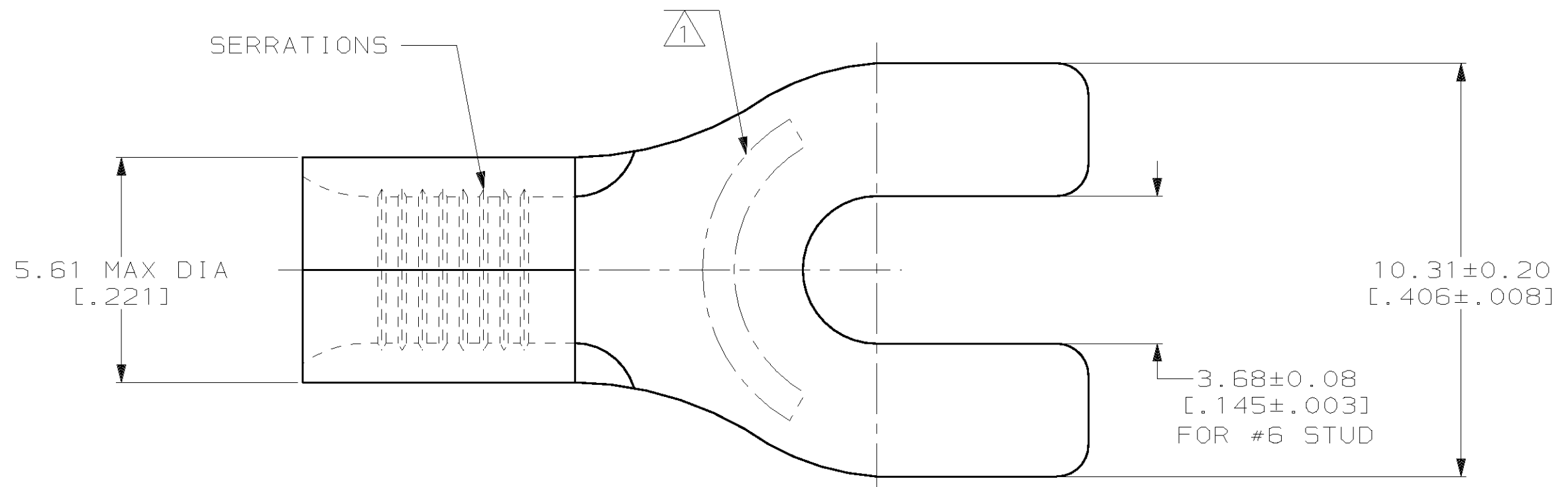

<b>AMP</b> WIRE RANGE	<b>UL</b> E13288 Listed
12-10 AWG STRANDED	12-10 AWG STRANDED
<b>CS</b> LR7189 Certified	MILITARY P/N AND CLASS
NOT CERTIFIED	NOT APPLICABLE

△ STAMP AMP 12-10\* APPROX AS SHOWN

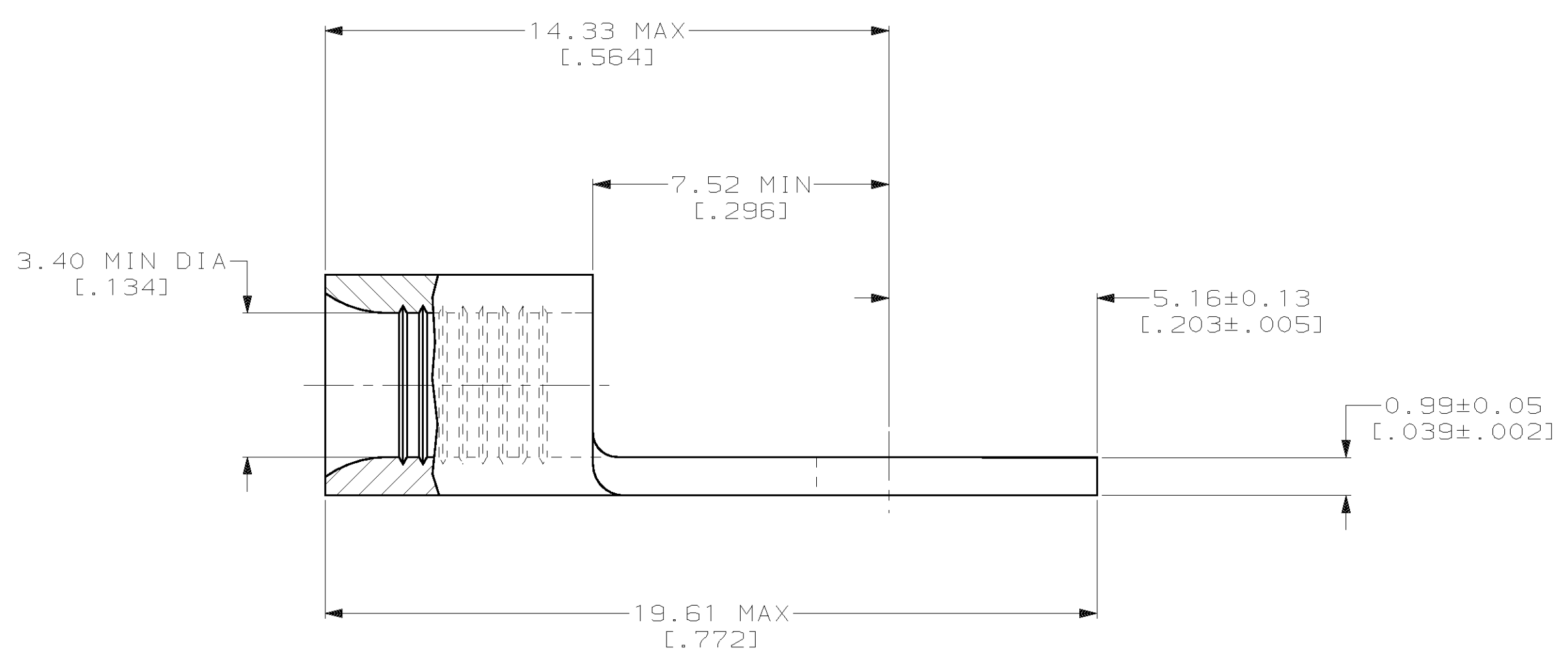

31587  
PART NO

**AMP INCORPORATED**  
**CUSTOMER SERVICE SYSTEMS**

FOR ADDITIONAL PRODUCT INFORMATION OR COPIES OF DRAWINGS AND TECHNICAL DOCUMENTS  
 PRODUCT INFORMATION CENTER  
 1-800-522-6752

FOR APPLICATION TOOLING INFORMATION  
 TOOLING ASSISTANCE CENTER  
 1-800-722-1111

FOR ORDER ENTRY  
 1-800-526-5142

MAX RECOMMENDED OPERATING TEMPERATURE:  
 170°C MAX

VOLTAGE RATING:  
 NOT APPLICABLE

WIRE CROSS SECTIONAL AREA RANGE:  
 2.62-6.64mm<sup>2</sup> [5,180-13,100] CIR MILS  
 STRANDED

THIS DRAWING IS A CONTROLLED DOCUMENT FOR AMP INCORPORATED. IT IS SUBJECT TO CHANGE AND THE CONTROLLING ENGINEERING ORGANIZATION SHOULD BE CONTACTED FOR THE LATEST REVISION.

DO NOT SCALE PRINT. UNLESS SPECIFIED DIMENSIONS IN mm [INCHES]— TOLERANCES ON :  
 2 PLC DEC ± -  
 3 PLC DEC ± -  
 ANGLES ± -

MATERIAL  
 COPPER PER ASTM B-152 ANNEALED

FINISH  
 TIN PLATE  
 0.00254 [.000100] MIN THK PER MIL-T-10727

DR 2-18-93 TA BRINKMAN  
 CHK 2-18-93 DA PATTERSON  
 APPD 2-18-93 DE MILLER  
 APPD 2-18-93 JL MECKLEY  
 PRODUCT SPEC -  
 APPLICATION SPEC -  
 WEIGHT -

**AMP** AMP Incorporated  
 Harrisburg, PA 17105-3608

NAME  
**TERMINAL, RING TONGUE, BUDGET**

SIZE CAGE CODE DRAWING NO  
 C 00779 C-31587

SCALE 8:1 SHEET 1 OF 1

单击下面可查看定价，库存，交付和生命周期等信息

[>>TE Connectivity\(泰科\)](#)