

THIS DRAWING IS UNPUBLISHED. RELEASED FOR PUBLICATION 20
 © COPYRIGHT 20 BY - ALL RIGHTS RESERVED.

REVISIONS				
P	LTR	DESCRIPTION	DATE	APVD
A		RELEASED TO PRODUCTION	08JUL2021	LN RL

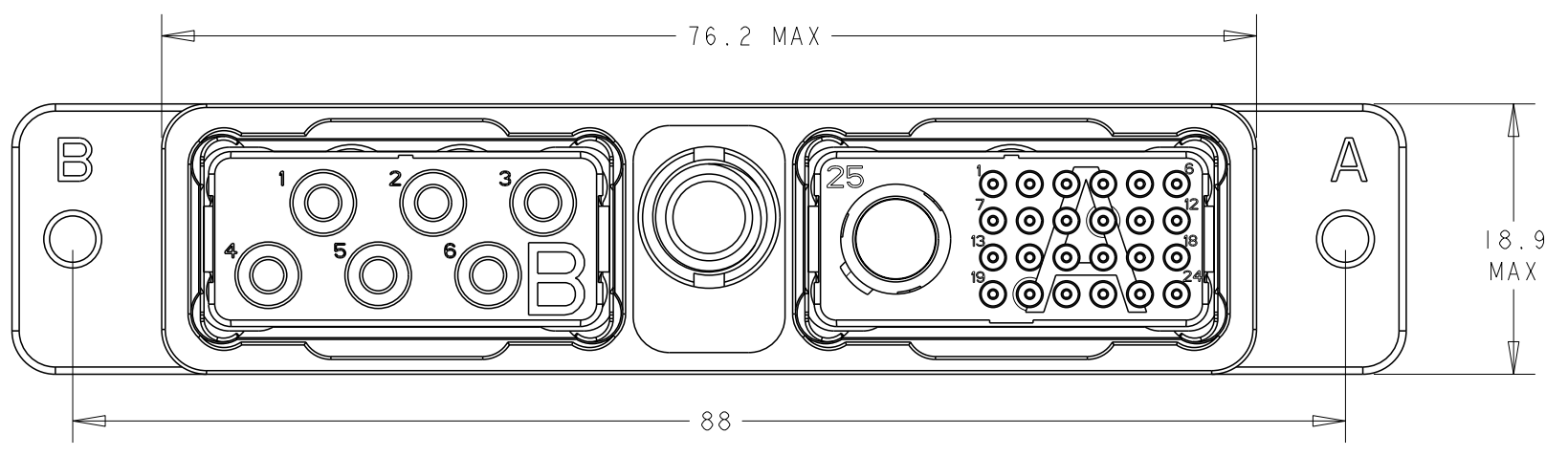

PART NUMBER 1877652-1 SHOWN

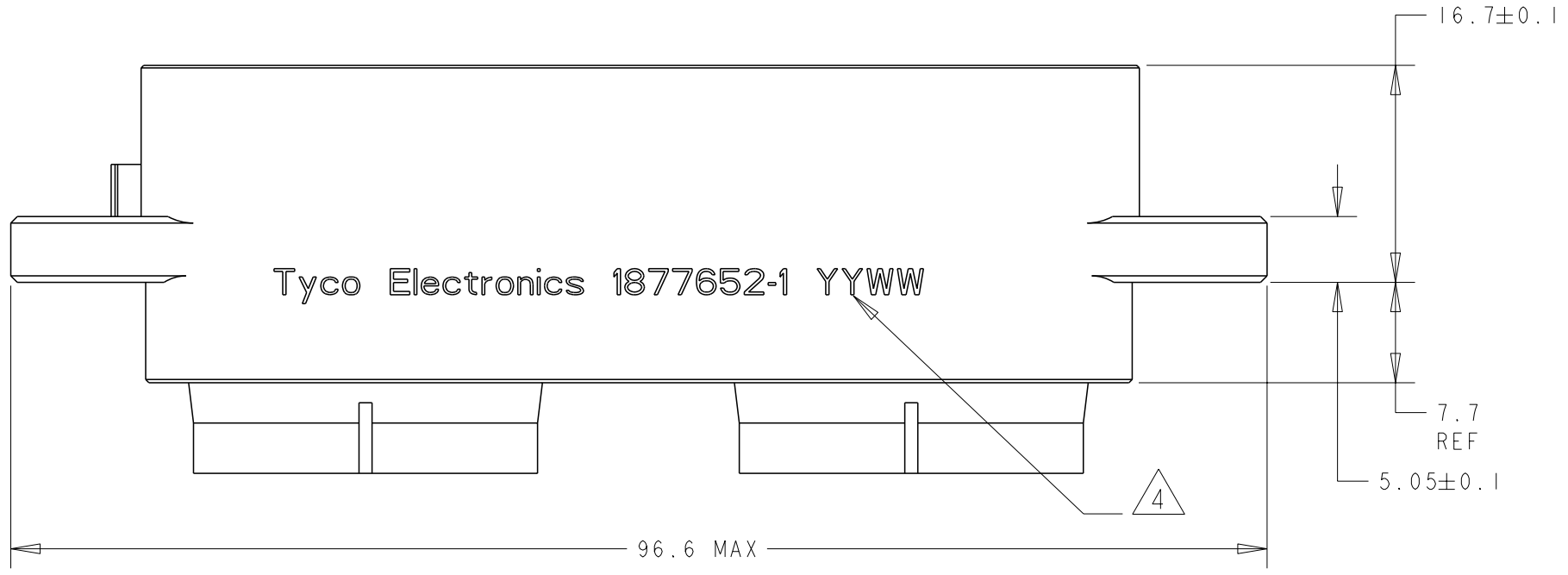
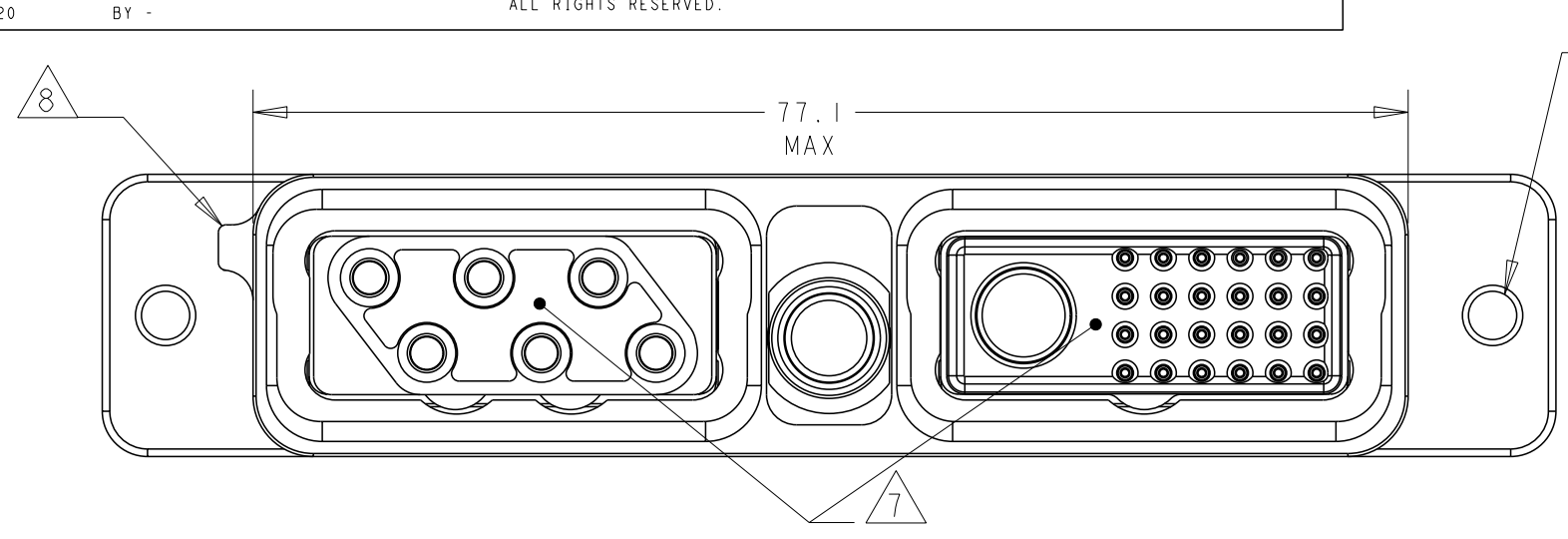
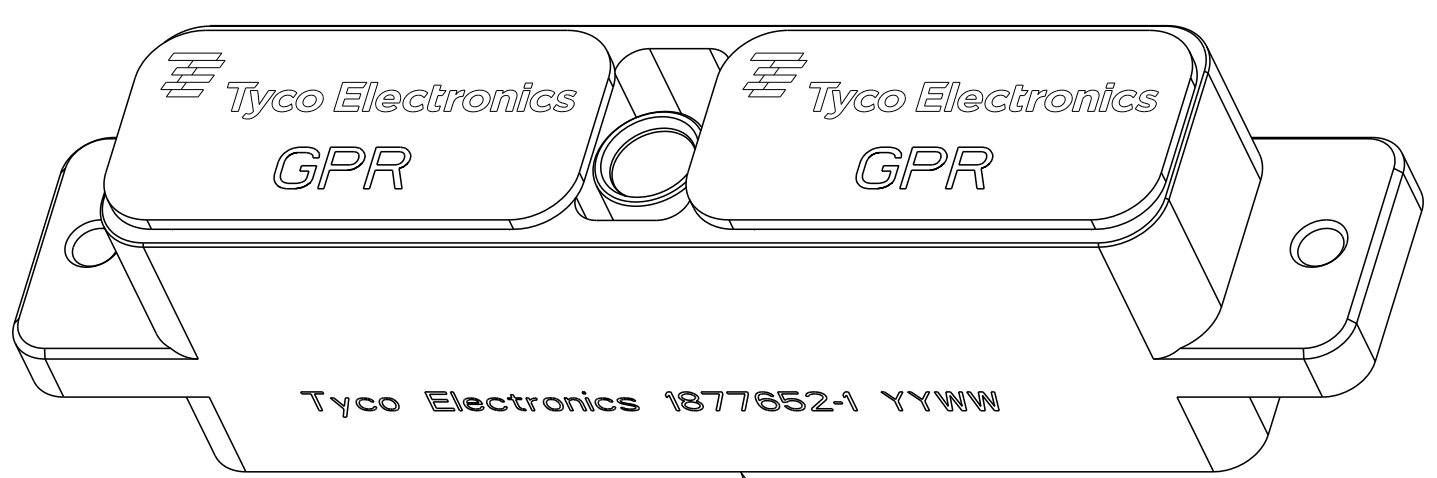

RECEPTACLE SHELL ASSEMBLY

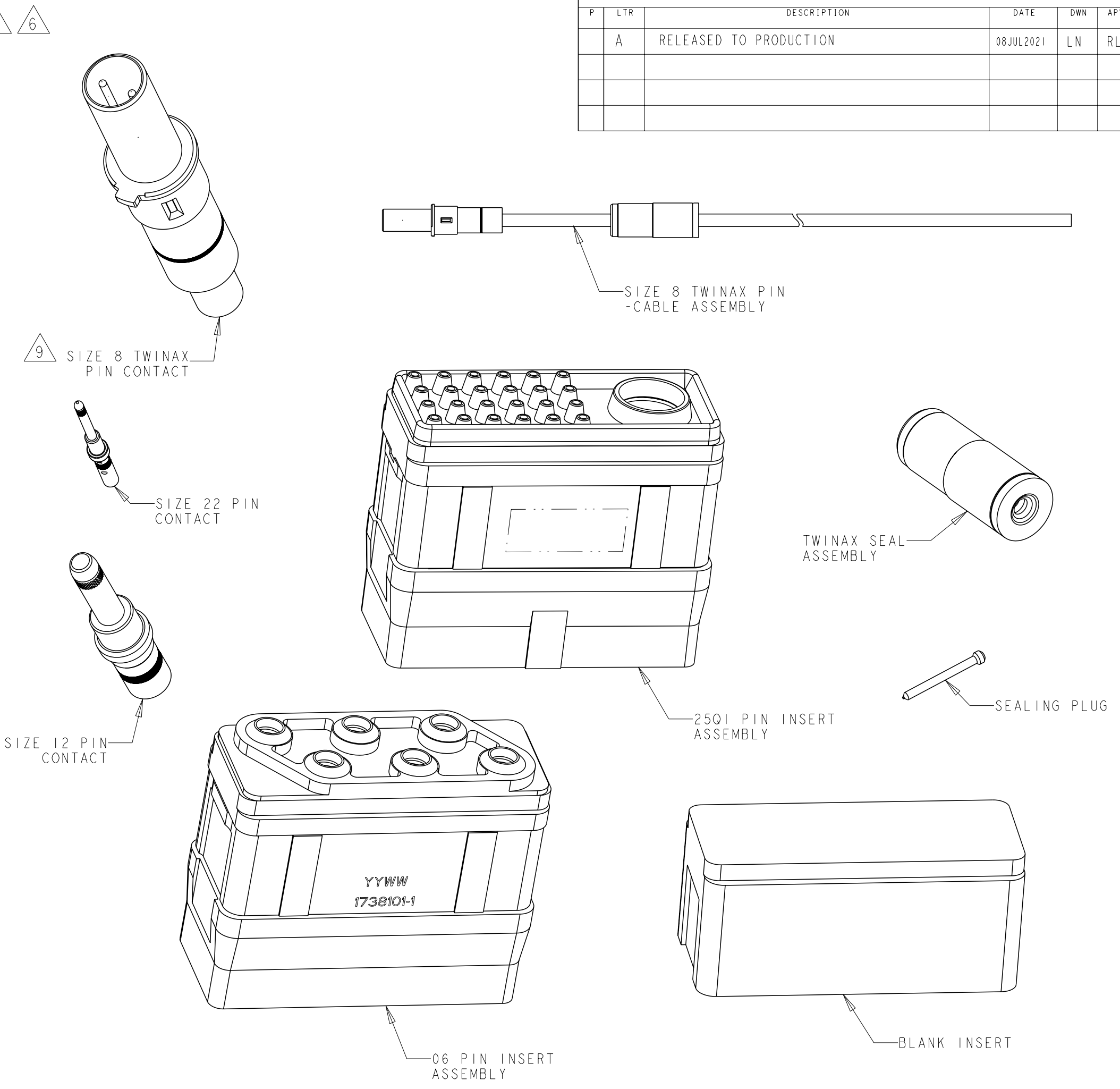

▲▲	-	1	-	6	24	1	1	-	1	1811119-2.QTY-1 SEE SHEET 1 DETAILS	1877652-7
▲▲	1	-	-	6	24	-	1	-	1	1811119-4.QTY 1 SEE SHEET 2 DETAILS	1877652-6
▲▲	-	1	-	6	24	1	1	-	1	1811119-4.QTY 1 SEE SHEET 2 DETAILS	1877652-5
▲▲	-	-	9	6	15	-	1	-	1	1811119-2.QTY-1 SEE SHEET 1 DETAILS	1877652-4
▲▲	-	-	-	6	-	-	1	-	1	1811119-2.QTY-1 SEE SHEET 1 DETAILS	1877652-3
▲▲	-	-	-	6	-	-	1	1	-	1811119-2.QTY-1 SEE SHEET 1 DETAILS	1877652-2
▲▲	-	1	9	6	15	1	1	-	1	1811119-2.QTY-1 SEE SHEET 1 DETAILS	1877652-1
	CABLE ASSEMBLY SIZE 8 TWINAX PIN 2102215-1	SEAL ASSEMBLY TWINAX 1954046-1	SEALING PLUG 592104-4	SIZE 12 PIN CONTACT 1738017-1	SIZE 22 PIN CONTACT 1738007-1	SIZE 8 TWINAX PIN CONTACT KIT, 1811865-3	06 PIN INSERT ASSEMBLY 1738101-1	BLANK INSERT 1738085-1	2501 PIN INSRT ASSEMBLY 1811121-1	RECEPTACLE SHELL	PART NUMBER

THIS DRAWING IS A CONTROLLED DOCUMENT.

DWN	BW	04 JAN 2006
CHK	JPM	04 JAN 2006
APVD	JPM	04 JAN 2006
PRODUCT SPEC	-	-
APPLICATION SPEC	-	-
WEIGHT	-	-
CUSTOMER DRAWING	SCALE	3:1

STE TE Connectivity

NAME: KIT, RECEPTACLE CONNECTOR, GAIN, GPRB2

SIZE: A2 CAGE CODE: 00779 DRAWING NO: C-1877652 RESTRICTED TO: 2

SHEET 1 OF 2 REV A

Printed on 8 Jul 2021 20:33 (India Standard Time) from TE307058

4

3

2

1

THIS DRAWING IS UNPUBLISHED. RELEASED FOR PUBLICATION 20
 © COPYRIGHT 20 BY - ALL RIGHTS RESERVED.

REVISIONS				
P	LTR	DESCRIPTION	DATE	APVD
-	-	SEE SHEET 1	-	-

1. THE RECEPTACLE CONNECTOR KITS CONSIST OF THE FOLLOWING ITEMS, WHICH ARE ALSO AVAILABLE SEPARATELY. THE QUANTITIES OF EACH ARE LISTED IN THE PART NUMBER TABLE.

1811119-2 OR 1811119-4 RECEPTACLE SHELL ASSEMBLY (UNMARKED)
 1811121-1 PIN INSERT ASSEMBLY, 250I, KEY A - INSTALLED.
 1738101-1 PIN INSERT ASSEMBLY, 06, KEY B - INSTALLED.
 1811865-3 PIN CONTACT, SIZE 8, TWINAX - NOT INSTALLED.
 1738007-1 PIN CONTACT, SIZE 22 - NOT INSTALLED.
 1738017-1 PIN CONTACT, SIZE 12 - NOT INSTALLED.
 592104-4 SEALING PLUG - NOT INSTALLED
 1954046-1 SEAL ASSEMBLY, TWINAX - NOT INSTALLED.
 1738085-1 BLANK INSERT - INSTALLED.
 2102215-1 CABLE ASSEMBLY, SINGLE-ENDED, PIN CONTACT TO 120Ω TWINAXIAL CABLE-NOT INSTALLED

2 SHELL ASSEMBLY:
 SHELL: ALUMINUM ALLOY 6061 T651 PER AMS-QQ-A-250
 INSERT RETENTION CLIP: COPPER ALLOY PER ASTM B194
 GUIDE SOCKET: STAINLESS STEEL PER AISI 303
 RETAINING NUT: STAINLESS STEEL PER AISI 316
 PROTECTIVE COVER: THERMOPLASTIC ELASTOMER

INSERT ASSEMBLIES:
 FRONT & REAR INSULATORS: HIGH-TEMP THERMOPLASTIC OR THERMOSET EPOXY PER ASTM D5948
 CONTACT RETENTION CLIPS: STAINLESS STEEL PER AISI 302 OR COPPER ALLOY PER ASTM B194
 REAR GROMMET & INTERFACIAL SEAL: FLUROSILICONE ELASTOMER PER MIL-R-25988 B EXCEPT 4.6.6.1

BLANK INSERT: PEI THERMOPLASTIC PER ASTM D5205.

SIZE 12 & SIZE 22 PIN CONTACTS:
 COPPER ALLOY C97

SIZE 8 TWINAX PIN CONTACT:
 OUTER SHELL AND CRIMP FERRULE: COPPER ALLOY PER ASTM B16
 FRONT AND REAR DIELECTRICS: HIGH-TEMP THERMOPLASTIC
 PIN CONTACTS: COPPER ALLOY PER ASTM B301

SEAL ASSEMBLY:
 SEAL SLEEVE: PPS THERMOPLASTIC PER ASTM D4067, COLOR: NATURAL.
 SEAL BOOT: FLUROSILICONE ELASTOMER PER SAE AMS-R-25988, EXCEPT 4.6.6.1.

SEALING PLUG:
 TEFLON PER MS27488.

CABLE ASSEMBLY:
 TWINAXIAL CABLE:
 JACKET: MODIFIED FEP
 SHIELD: COPPER, AWG 40
 FILLERS: FEP
 DIELECTRIC: RAYFOAM H
 CONDUCTORS: HIGH-STRENGTH COPPER ALLOY, AWG 26; 7 STRANDS OF AWG 34
 SIZE 8 TWINAX PIN CONTACT ASSEMBLY: MATERIALS AS LISTED ABOVE
 SEAL ASSEMBLY: MATERIALS AS LISTED ABOVE

3 SHELL ASSEMBLY: ELECTROLYTIC NICKEL PER SAE AMS QQ-N-290 OVER ELECTROLESS NICKEL PER SAE AMS-2404, CLASS 3.

GUIDE SOCKET: PASSIVATED

SIZE 12 AND 22 PIN CONTACTS: 1.27μm MIN GOLD PER ASTM B488 OVER 2.54μm MIN NICKEL PER QQ-N-290 ON ENTIRE STOCK.

SIZE 8 TWINAX PIN CONTACT:
 OUTER SHELL, PIN CONTACTS AND CRIMP FERRULE: 1.27μm MIN GOLD PER ASTM B488 OVER 1.27μm MIN NICKEL PER QQ-N-290 ON ENTIRE STOCK.

CABLE ASSEMBLY:
 TWINAXIAL CABLE:
 SHIELD & CONDUCTORS: SILVER
 SIZE 8 TWINAX PIN CONTACT ASSEMBLY: FINISHES AS LISTED ABOVE

4 DATE CODE - YEAR & WEEK (YY - WW)

5 6-32 SCREWS ARE REQUIRED FOR PANEL MOUNTING (NOT INCLUDED).
 SCREW HEAD DIAMETER: 8.5mm MAX
 RECOMMENDED TORQUE: 1.3 N·m [11.5 lb_in] MIN

6 6-32 THREADED HOLES ARE SELF-LOCKING, HAVING THE SPIRALOCK® THREAD FORM. SPIRALOCK® IS A REGISTERED TRADEMARK OF SPIRALOCK CORPORATION.

7 THE PROTECTIVE COVERS ARE NOT SHOWN FOR CLARITY.

8 POLARIZATION FEATURE TO PREVENT REAR PANEL MOUNTING.

9 TWINAX CONTACT COMPONENTS ARE PACKAGED IN KIT FORM. THE CABLE MUST BE PURCHASED SEPARATELY.

10. THIS PRODUCT IS SOLD BY TYCO ELECTRONICS UNDER A LICENSE FROM RADIAL SA.

11 THIS PART IS PRELIMINARY - NOT RELEASED FOR PRODUCTION.

RECOMMENDED PANEL CUTOUT

PART NUMBER 1877652-5 SHOWN, ALL DIMENSIONS SAME AS 1877652-1 EXCEPT AS NOTED

THIS DRAWING IS A CONTROLLED DOCUMENT.		DWN BW	04JAN06	 TE Connectivity
		CHK JPM	04JAN06	
		APVD JPM	04JAN06	
		PRODUCT SPEC		
DIMENSIONS: mm		TOLERANCES UNLESS OTHERWISE SPECIFIED:		NAME KIT, RECEPTACLE CONNECTOR, GAIN, GPRB2
0 PLC ±0.2		1 PLC ±0.2		SIZE
2 PLC ±0.2		3 PLC ±		CAGE CODE
4 PLC ±		ANGLES ±		DRAWING NO
FINISH		FINISH		RESTRICTED TO
MATERIAL		WEIGHT		A200779
		CUSTOMER DRAWING		C-1877652
		SCALE 3:1		SHEET 2 OF 2
		REV A		

1471-9 (3/13)

Downloaded From Onevac.com

单击下面可查看定价，库存，交付和生命周期等信息

[>>TE Connectivity\(泰科\)](#)