

THIS DRAWING IS UNPUBLISHED. RELEASED FOR PUBLICATION
 © COPYRIGHT - By - ALL RIGHTS RESERVED.

REVISIONS					
P	LTR	DESCRIPTION	DATE	DWN	APVD
Y		REVISED PER ECO-12-012320	04JUL12	KH	MZ
Z		REVISED PER ECO-17-009977	12JUL2017	RS	MZ

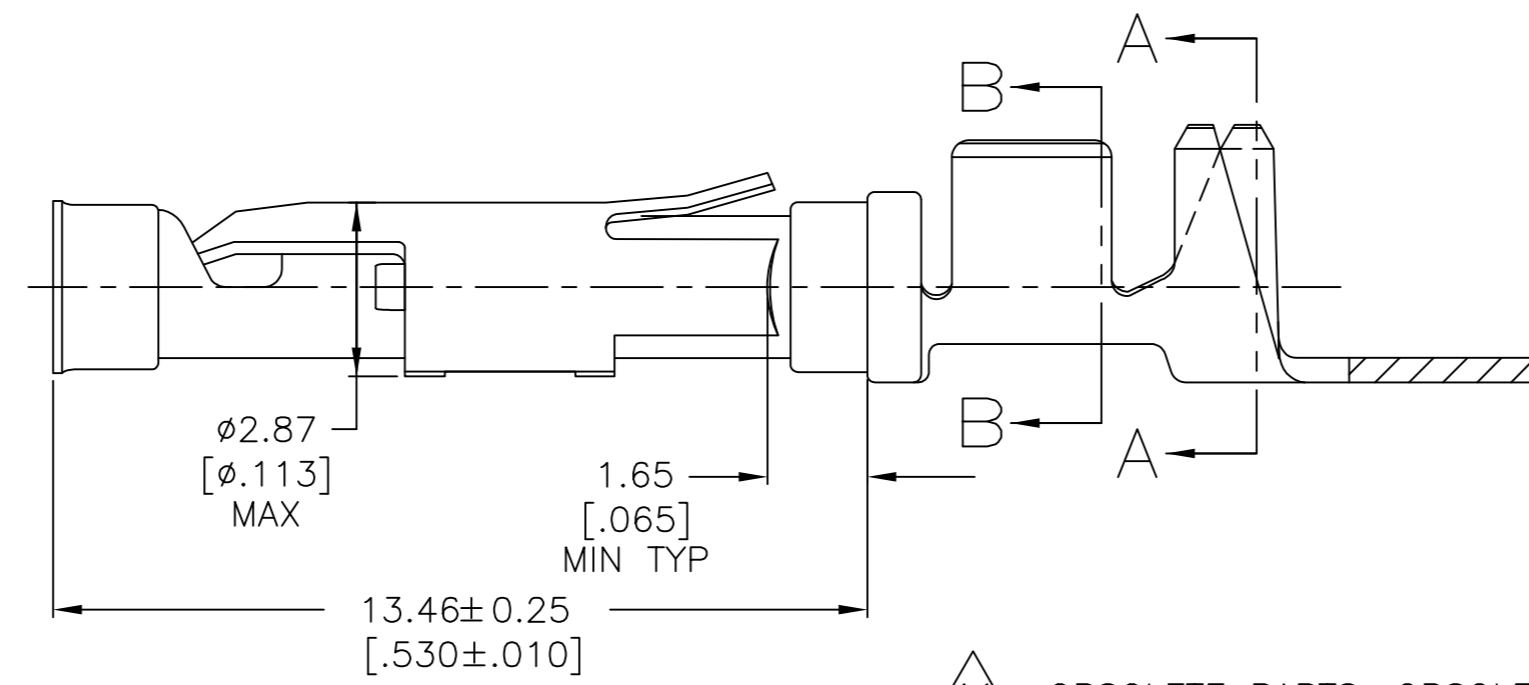
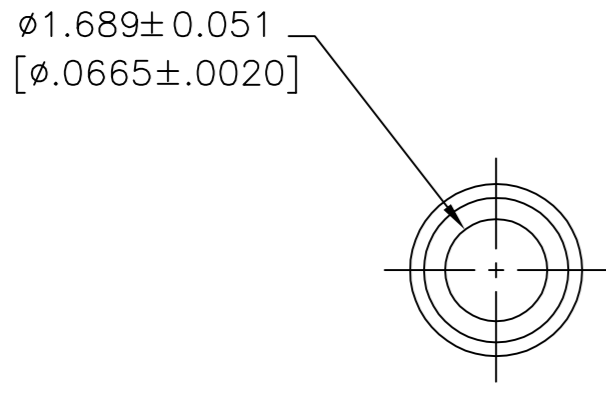
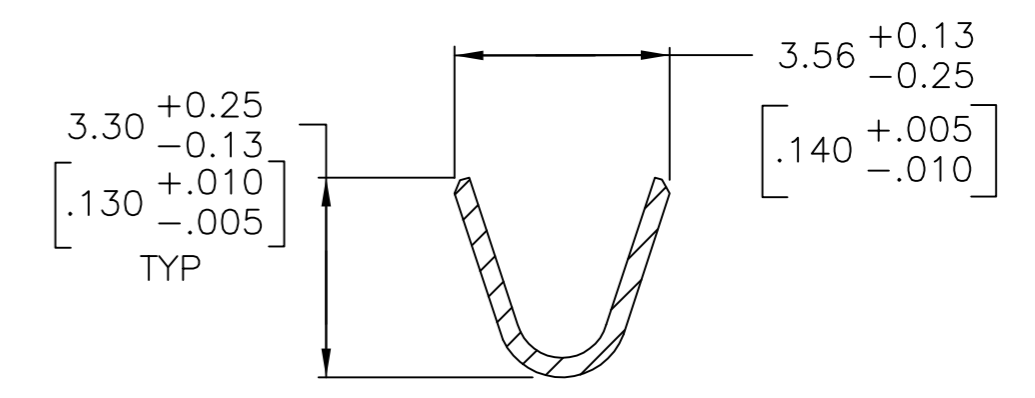
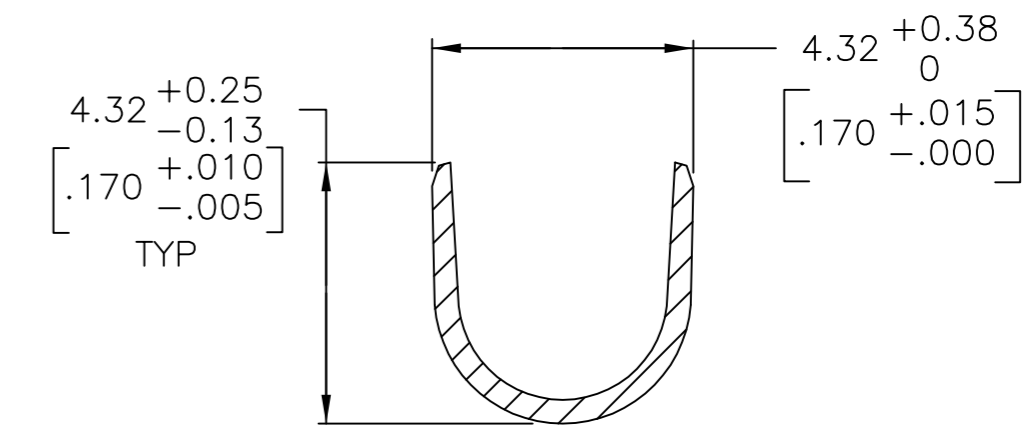
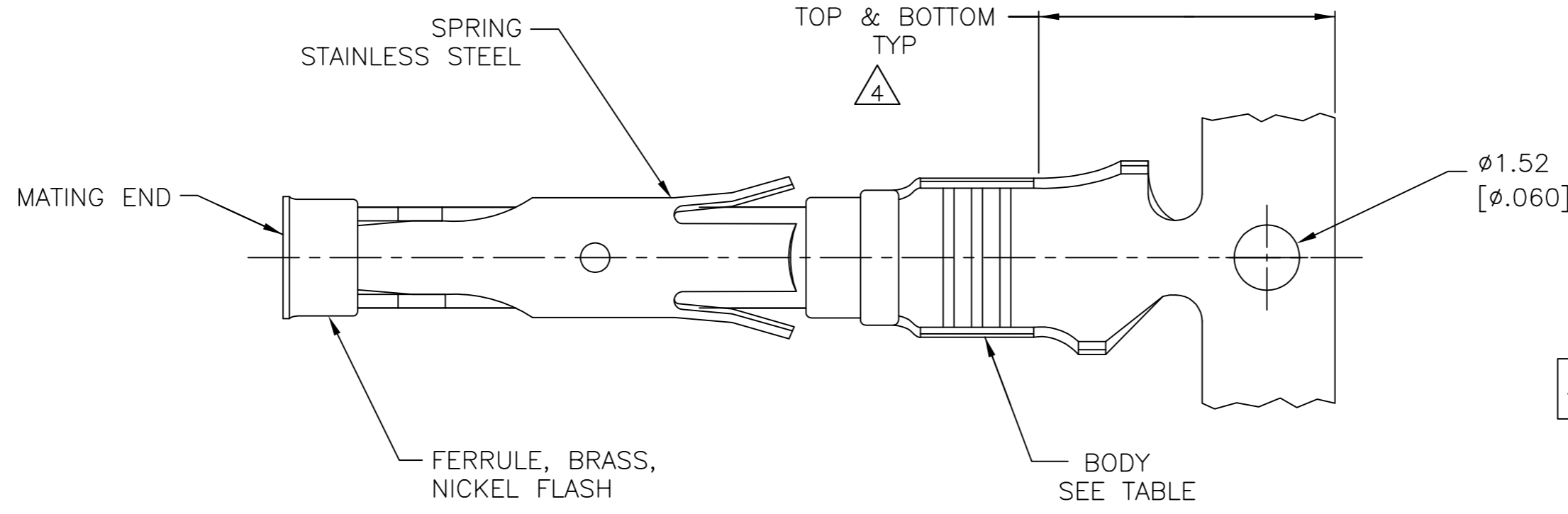

- 1 0.51µm [.000020] MIN GOLD PER MIL-G-45204 ON MATING END FOR A LENGTH OF 5.08 [.200] MIN WITH GOLD FLASH ON THE REMAINDER OVER 0.76µm [.000030] MIN NICKEL PER QQ-N-290.
- 2 1.27µm [.000050] MIN TIN-LEAD PER MIL-T-10727 OVER 0.76µm [.000030] MIN NICKEL PER QQ-N-290.
- 3 0.76µm [.000030] MIN GOLD PER MIL-G-45204 ON MATING END FOR A LENGTH OF 5.08 [.200] MIN WITH GOLD FLASH ON THE REMAINDER OVER 0.76µm [.000030] MIN NICKEL PER QQ-N-290.
- 4 GOLD PLATING NEED NOT APPEAR IN THIS AREA.
- 5 REVERSE REELED FOR MINI-APPLICATOR.
- 6 WIRE RANGE 14-18 AWG. INSULATION RANGE 2.79[.110]-3.81[.150].
- 7 0.38µm [.000015] MIN GOLD PER MIL-G-45204 ON MATING END FOR A LENGTH OF 5.08 [.200] MIN, 1.27µm [.000050] MIN TIN-LEAD PER MIL-T-10727 FOR A LENGTH OF 5.69 [.224] MIN ON OPPOSITE END, BOTH OVER 1.27µm [.000050] MIN NICKEL PER QQ-N-290 ON ENTIRE CONTACT.
- 8 1.27µm [.000050] MIN TIN PER MIL-T-10727 OVER 0.76µm [.000030] MIN NICKEL PER QQ-N-290.
- 9 0.38µm [.000015] MIN. GOLD PER MIL-G-45204 ON MATING END FOR A LENGTH OF 5.08 [.200] MIN. WITH GOLD FLASH ON THE REMINDER, OVER 1.27µm [.000050] MIN. NICKEL PER QQ-N-290.
- 10 PRELIMINARY - NOT FOR PRODUCTION.

- 11 OBSOLETE PARTS: OBSOLETE CIS STREAMLINING PER D.RENAUD/D.SINISI
- 12 0.76µm [.000030] MIN GOLD PER MIL-G-45204 ON MATING END FOR A LENGTH OF 5.08 [.200] MIN WITH 1.27µm [.000050] MIN MATTE TIN PLATE IN WIRE CRIMP AREA, BOTH OVER .76µm [.000030] MIN NICKEL PER QQ-N-290.

FINISH	BODY MATERIAL	LOOSE PIECE REF	PART NUMBER
9	CU-NI ALLOY	-	1-66598-5
8	BRASS	-	1-66598-4
8	PHOSPHOR BRONZE	-	1-66598-3
8	CU-NI ALLOY	1-66601-2	1-66598-2
3	CU-NI ALLOY	1-66601-0	1-66598-1
8	BRASS	-	1-66598-0
8	BRASS	66601-9	66598-9
7	BRASS	66601-5	66598-8
2	BRASS	-	66598-7
3	PHOSPHOR BRONZE	66601-4	66598-6
2	PHOSPHOR BRONZE	66601-3	66598-5
1	BRASS	-	66598-3
12	BRASS	66601-2	66598-2
2	BRASS	66601-1	66598-1

THIS DRAWING IS A CONTROLLED DOCUMENT.

DWN: M.HOFFECKER 8-11-88
 CHK: J.McCLINTON 8-11-88

TE Connectivity

SOCKET ASSEMBLY, .062, TYPE III+

SIZE: A2 CAGE CODE: 00779 DRAWING NO: C=66598 RESTRICTED TO: -

SCALE: 8:1 SHEET: 1 of 1 REV: Z

单击下面可查看定价，库存，交付和生命周期等信息

[>>TE Connectivity\(泰科\)](#)