

| REVISIONS | | | | | |
|-----------|-----|---------------|-----------|-----|------|
| P | LTR | DESCRIPTION | DATE | DWN | APVD |
| A | | ECO-18-017212 | 30NOV2018 | FL | HL |

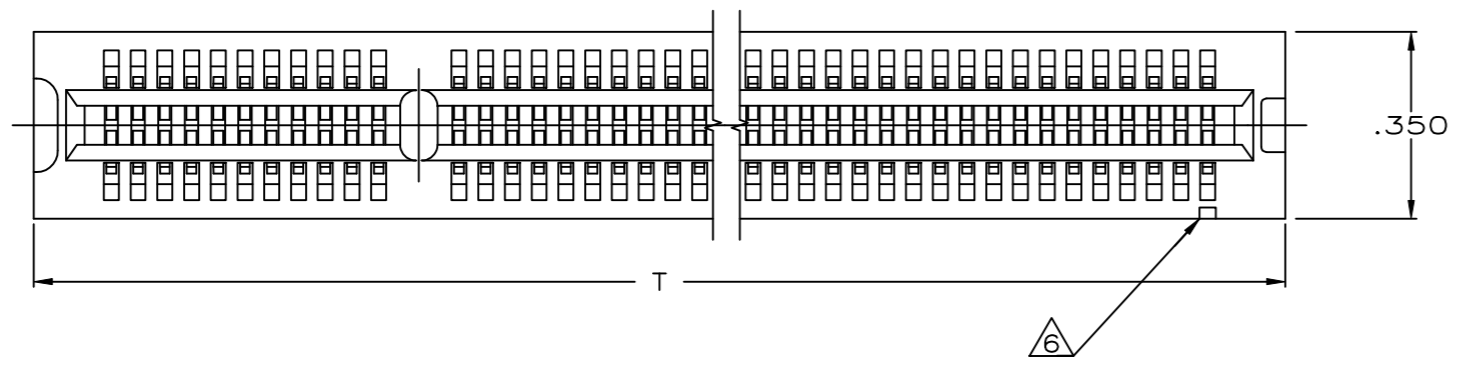

- ① HOUSING: HIGH TEMPERATURE THERMOPLASTIC. COLOR: BROWN.
- ② CONTACT: PHOSPHOR BRONZE.
- ③ CONTACT FINISH: .000100 MIN NICKEL ALL OVER.
.000030 MIN GOLD OVER NICKEL IN CONTACT AREA.
.000100 MIN MATTE TIN OVER NICKEL ON SOLDER TAILS.
- ④ DISTANCE FROM CONTACT POINT TO BOTTOM OF CARD SLOT.
- ⑤ AMP PART NUMBER, DATE CODE AND CSA LOGO MARKED IN APPROXIMATE AREA SHOWN.
- ⑥ PIN ONE IDENTIFIER NOTCH ONLY ON PART NUMBERS INDICATED.

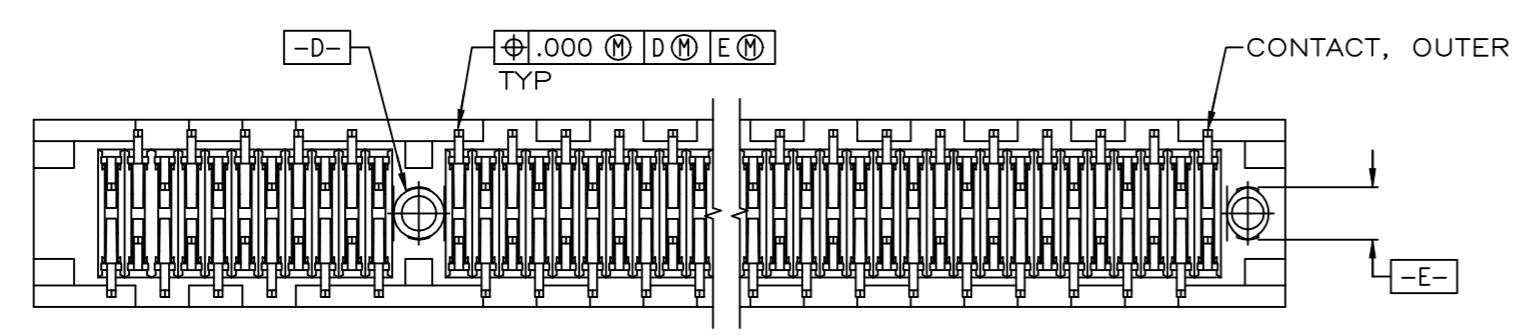
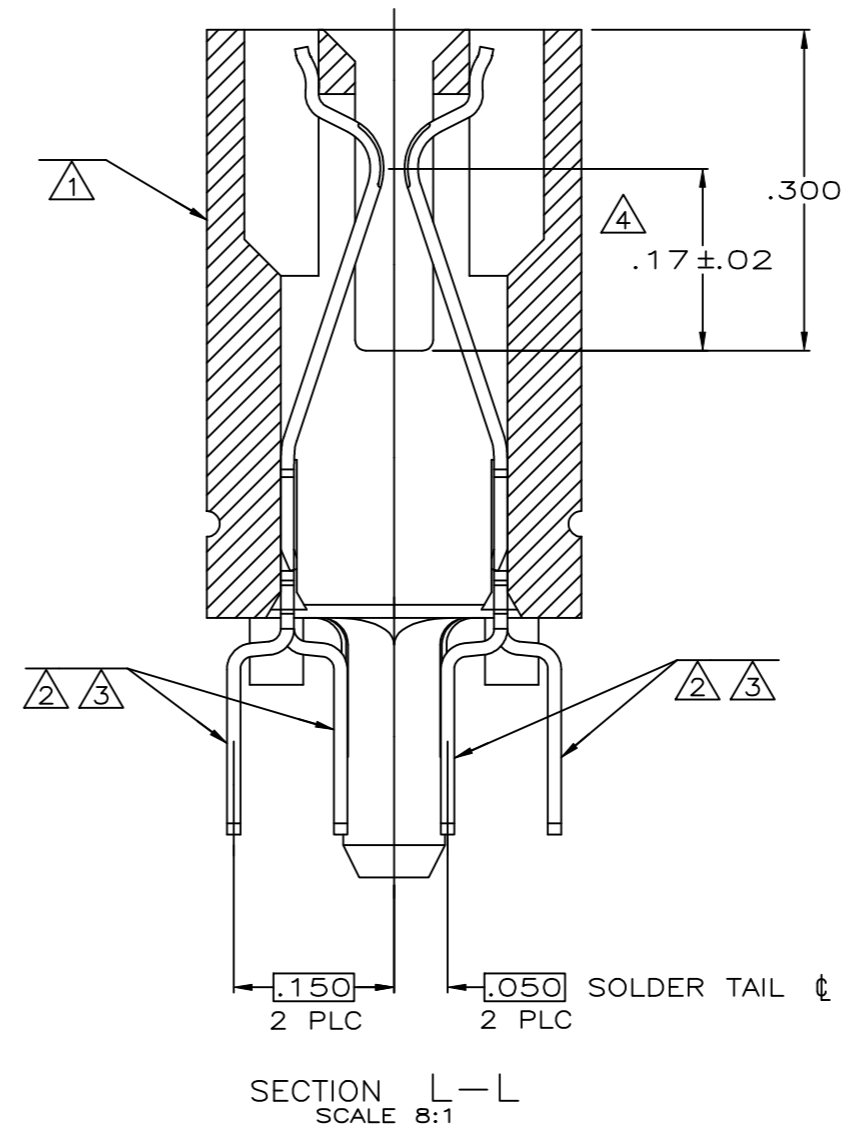
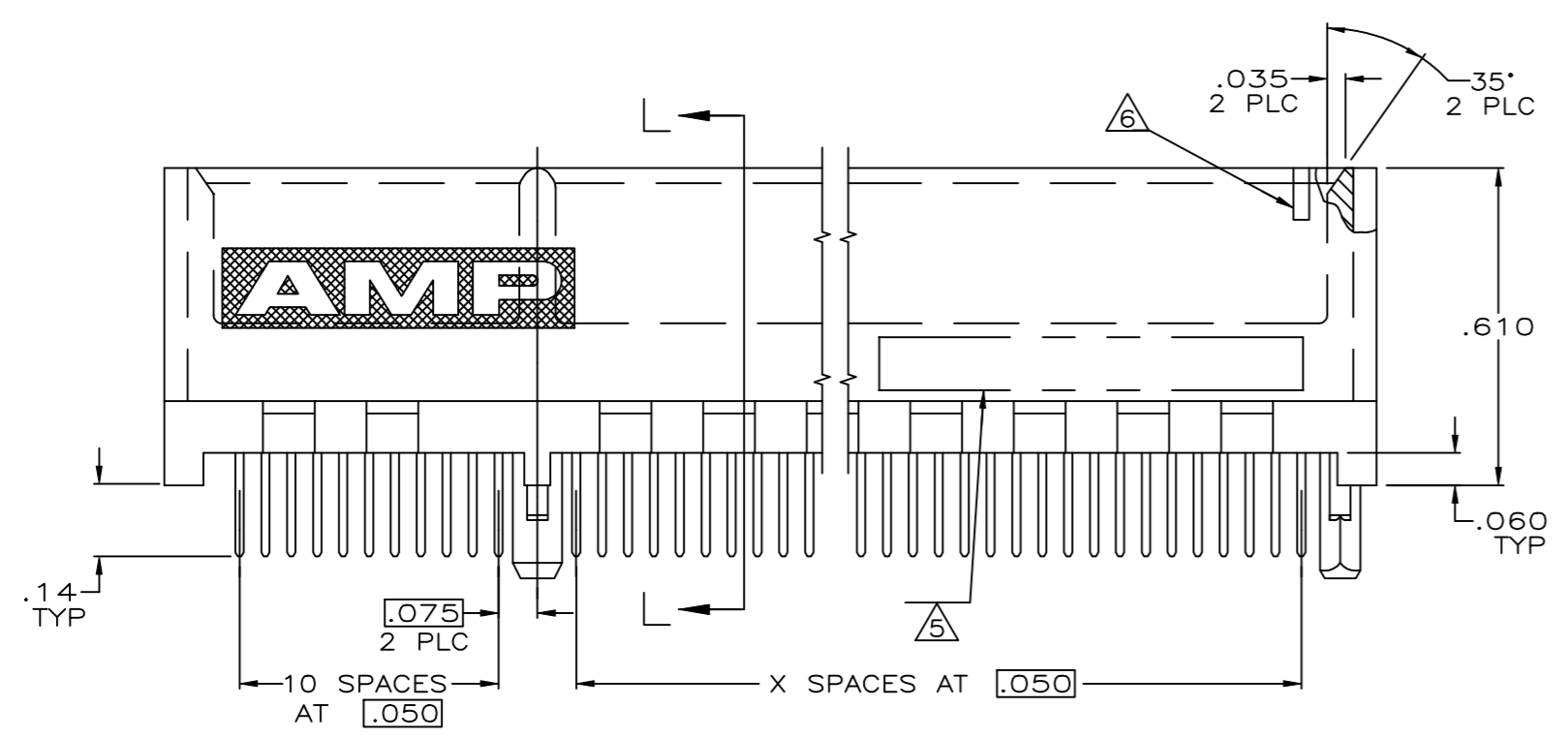

SEE SHEET 2 FOR HOLE PATTERNS

| | | | | | | | |
|--------------------|--------------|-------|-------|------|----|-----------------|-------------|
| NO | B | .700 | .660 | 1.49 | 11 | 23 | 5650181-3 |
| NO | A | 1.550 | 1.510 | 2.34 | 28 | 40 | 5650181-2 |
| YES | A | 2.350 | 2.310 | 3.14 | 44 | 56 | 5650181-1 |
| PIN ONE IDENTIFIER | HOLE PATTERN | V | U | T | X | NO OF DUAL POSN | PART NUMBER |

THIS DRAWING IS A CONTROLLED DOCUMENT. DWN: AL FRANTUM 24 JUN 05, DK: AL FRANTUM 24 JUN 05, APVD: -

TE TE Connectivity Ltd.

CONNECTOR ASSEMBLY, DUAL POSITION, .050 SERIES.

PRODUCT SPEC: 108-14034
 APPLICATION SPEC: 114-26012

SIZE: A1, CAGE CODE: 00779, DRAWING NO: 5650181, WEIGHT: -

CUSTOMER DRAWING, SCALE: 4:1, SHEET: 1 OF 2, REV: A

| REVISIONS | | | | |
|-----------|-----|-------------|------|----------|
| P | LTR | DESCRIPTION | DATE | OWN APVD |
| - | - | SEE SHEET 1 | - | - |

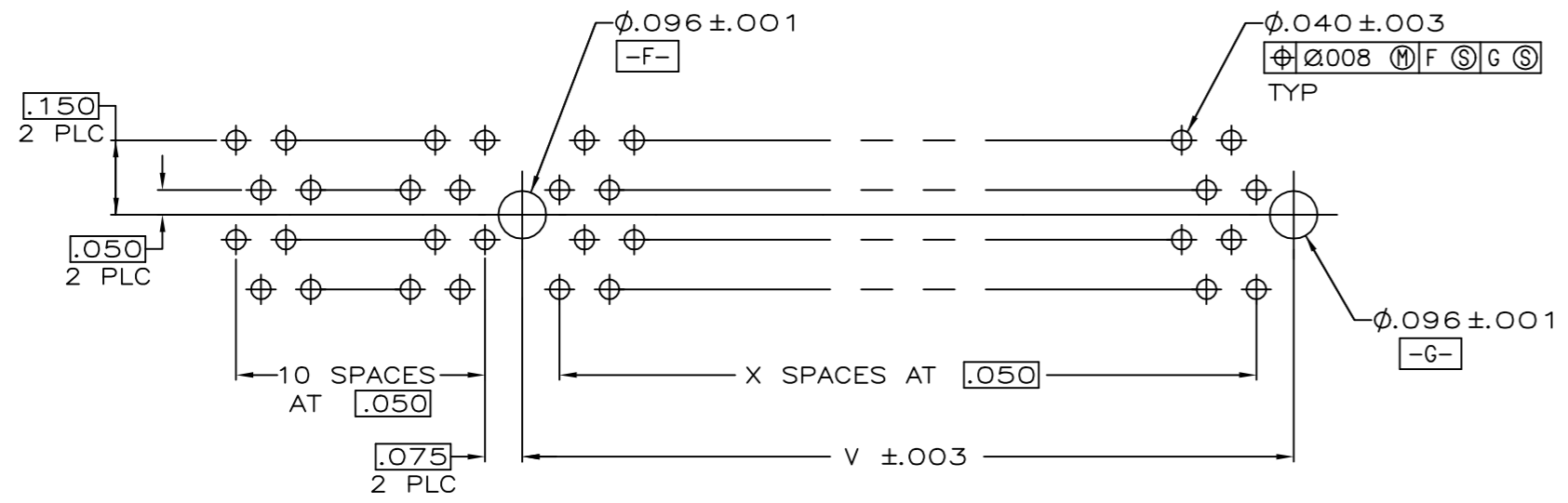

RECOMMENDED CONNECTOR MOUNTING HOLE PATTERN A
 (CONNECTOR SIDE SHOWN)

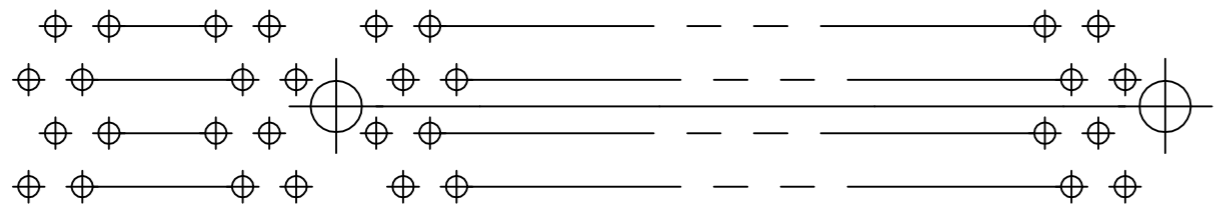

RECOMMENDED CONNECTOR MOUNTING HOLE PATTERN B
 (CONNECTOR SIDE SHOWN)

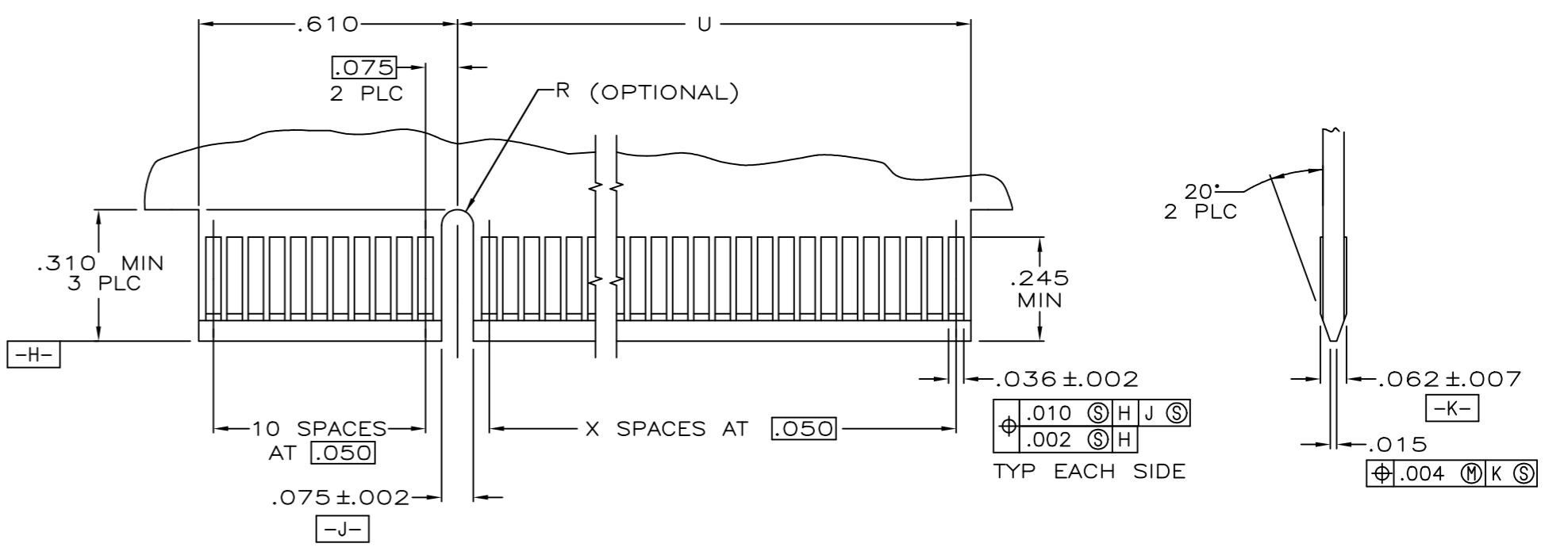

RECOMMENDED MATING BOARD EDGE CONFIGURATION

| | | | | |
|--|-----------------------|--|----------------------|--|
| THIS DRAWING IS A CONTROLLED DOCUMENT. | | OWN AL FRANTUM 24 JUN 05 | TE Connectivity Ltd. | |
| | | CHK AL FRANTUM 24 JUN 05 | | |
| DIMENSIONS: INCHES | | APVD | | NAME |
| 0 PLC ± - 1 PLC ± - 2 PLC ± .01 3 PLC ± .005 4 PLC ± - ANGLES ± - | | TOLERANCES UNLESS OTHERWISE SPECIFIED: 0 PLC ± - 1 PLC ± - 2 PLC ± .01 3 PLC ± .005 4 PLC ± - ANGLES ± - | | PRODUCT SPEC 108-14034 APPLICATION SPEC 114-26012 |
| MATERIAL SEE SHEET 1 | FINISH SEE SHEET 1 | WEIGHT - | SIZE A1 | CAGE CODE 00779 DRAWING NO 5650181 |
| CUSTOMER DRAWING | | SCALE 4:1 | SHEET 2 | REV A |

单击下面可查看定价，库存，交付和生命周期等信息

[>>TE Connectivity\(泰科\)](#)