

THIS DRAWING IS UNPUBLISHED. RELEASED FOR PUBLICATION, 19 .
 © COPYRIGHT 19 BY AMP INCORPORATED. ALL INTERNATIONAL RIGHTS RESERVED.

LOC		DIST		REVISIONS				DATE	APPD
ZONE	LTR	DESCRIPTION							
G	14	P	F	E	REL PER 0G3A-0501-01		11DEC01	JR/MS	

METRIC
 DIMENSIONS LISTED IN mm [INCHES]

AMP WIRE RANGE	UL E13288 Listed
16-14 AWG STRANDED	16-14 AWG STRANDED
SP LR7189 Certified	MILITARY P/N AND CLASS
NOT CERTIFIED	NOT APPLICABLE

1 STAMP AMP 16-14* APPROX AS SHOWN

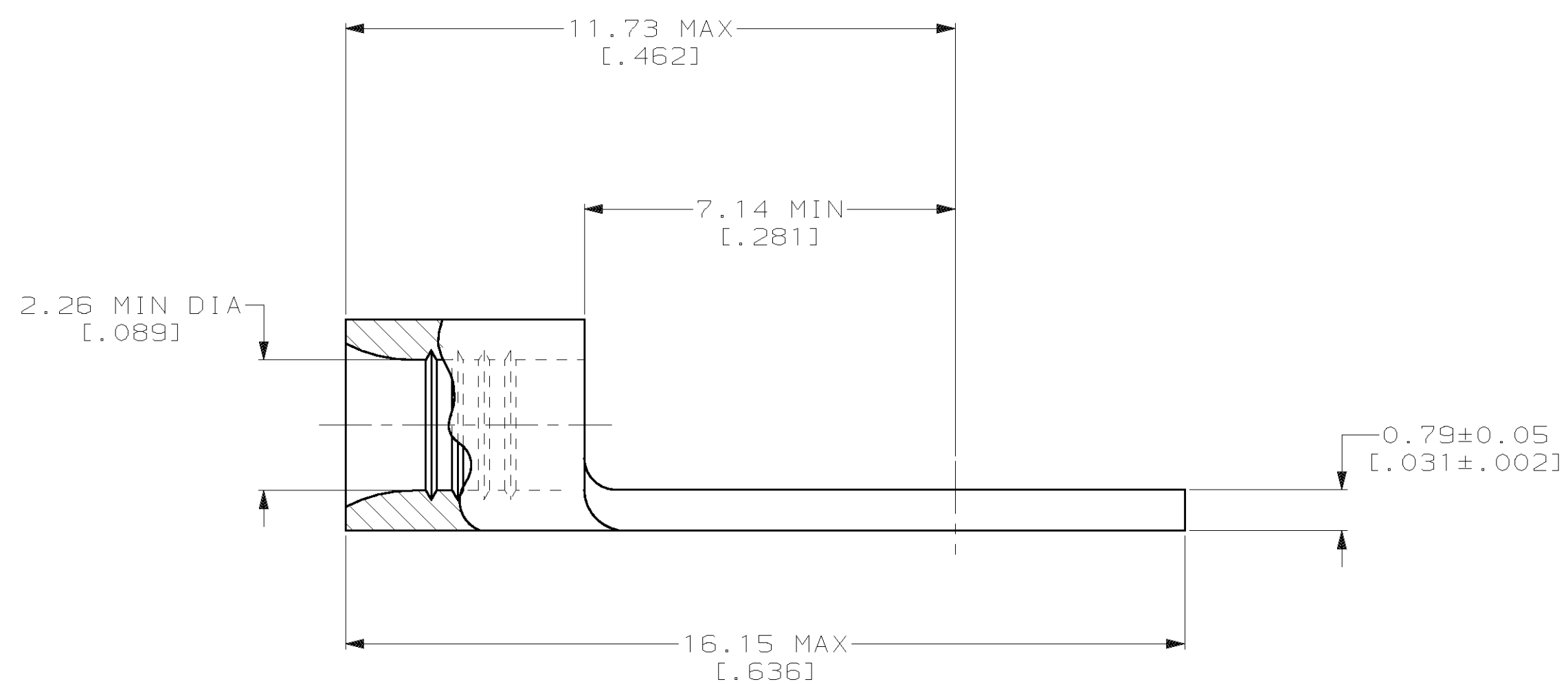
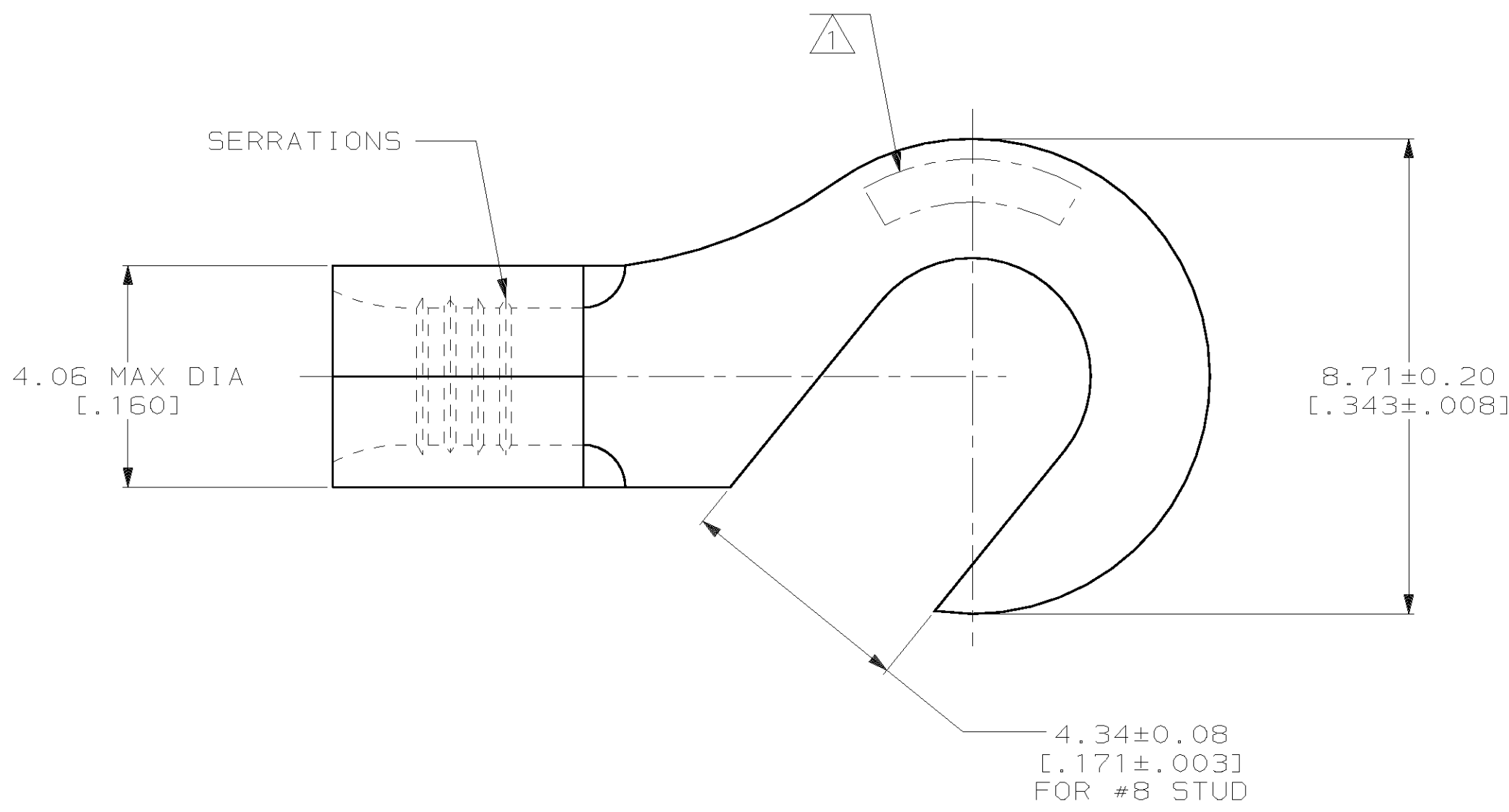

5,000	ON TAPE	32503-2
-	LOOSE PIECE	32503
QTY	PACKAGE TYPE	PART NO

AMP INCORPORATED
CUSTOMER SERVICE SYSTEMS

FOR ADDITIONAL PRODUCT INFORMATION OR COPIES OF DRAWINGS AND TECHNICAL DOCUMENTS
 PRODUCT INFORMATION CENTER
 1-800-522-6752

FOR APPLICATION TOOLING INFORMATION
 TOOLING ASSISTANCE CENTER
 1-800-722-1111

FOR ORDER ENTRY
 1-800-526-5142

MAX RECOMMENDED OPERATING TEMPERATURE:
 170°C MAX

VOLTAGE RATING:
 NOT APPLICABLE

WIRE CROSS SECTIONAL AREA RANGE:
 1.04-2.62mm² [2,050-5,180] CIR MILS
 STRANDED

THIS DRAWING IS A CONTROLLED DOCUMENT FOR AMP INCORPORATED. IT IS SUBJECT TO CHANGE AND THE CONTROLLING ENGINEERING ORGANIZATION SHOULD BE CONTACTED FOR THE LATEST REVISION.

DO NOT SCALE PRINT. UNLESS SPECIFIED DIMENSIONS IN mm [INCHES] - TOLERANCES ON :
 2 PLC DEC ± -
 3 PLC DEC ± -
 ANGLES ± -

MATERIAL
 COPPER PER ASTM B-152 ANNEALED

FINISH
 TIN PLATE
 0.00254 [.000100] MIN THK PER MIL-T-10727

DR 2-27-93 TA BRINKMAN
 CHK 2-27-93 DA PATTERSON
 APPD 2-27-93 DE MILLER
 APPD 2-27-93 JL MECKLEY
 PRODUCT SPEC -
 APPLICATION SPEC -
 WEIGHT -

AMP AMP Incorporated
 Harrisburg, PA 17105-3608

NAME
TERMINAL, HOOK TONGUE, BUDGET

SIZE CAGE CODE DRAWING NO
 C 00779 C-32503

SCALE 10:1 SHEET 1 OF 1

单击下面可查看定价，库存，交付和生命周期等信息

[>>TE Connectivity\(泰科\)](#)