

REVISIONS					
P	LTR	DESCRIPTION	DATE	DMN	APVD
C		REVISED PER ECO-20-001912	04JUN2020	SB	JO

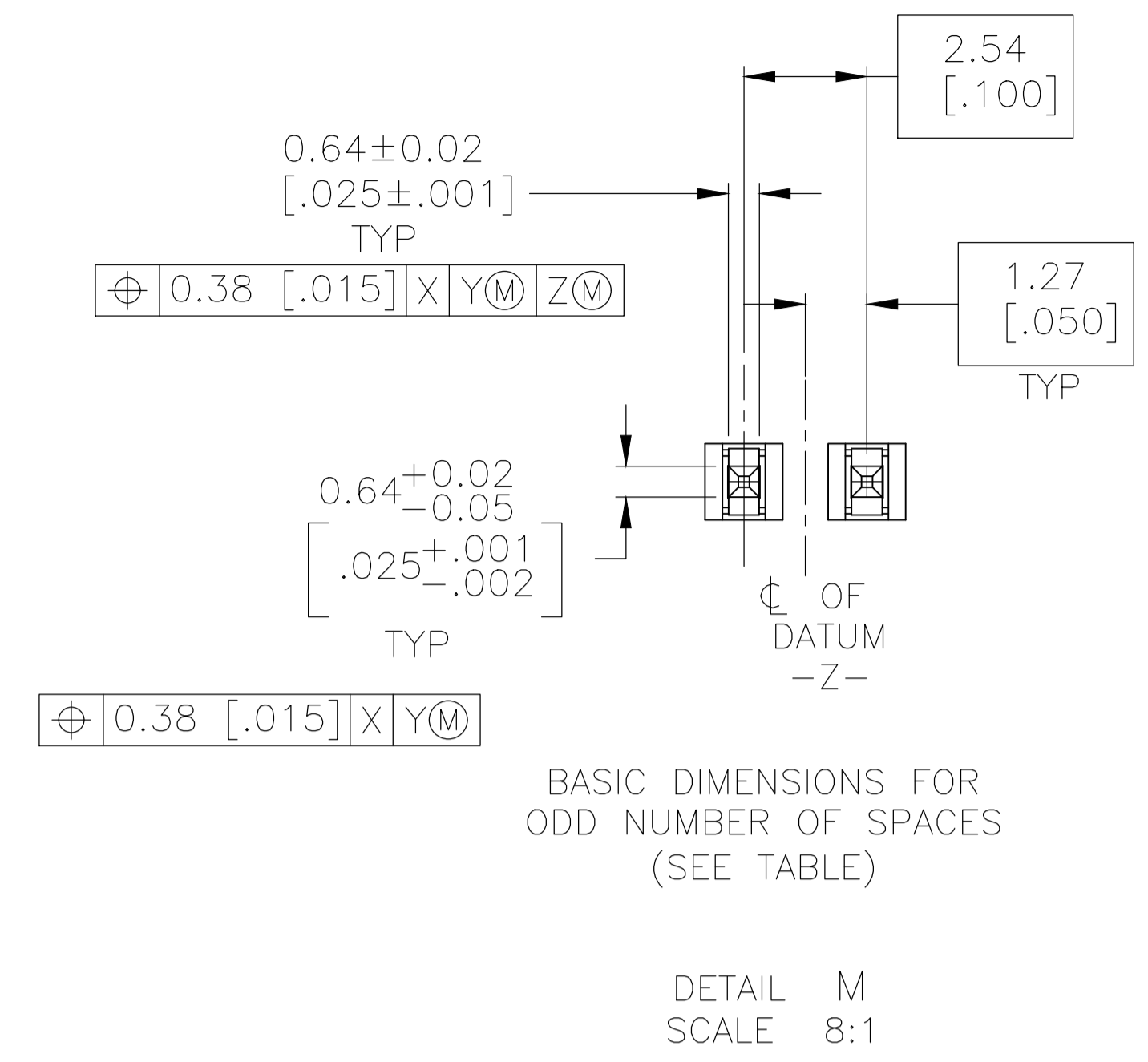

- 1 HOUSING: HIGH TEMPERATURE THERMOPLASTIC, COLOR-BLACK. POST: BRASS.
- 2 DATUMS AND BASIC DIMENSIONS ESTABLISHED BY THE CUSTOMER.
- 3 TWO POLARIZATION SLOTS ON ASSEMBLIES WITH FOUR OR MORE POSITIONS.
- 4 0.00254-0.00508 [.000100-.000200] MATTE TIN OVER
0.00127-0.00254 [.000050-.000100] NICKEL.
- 5 PARTS ARE PACKAGED IN TAPE AND REEL PER EIA-481 SPECIFICATIONS. SEE TABLE FOR TAPE WIDTHS.
- 6 PRELIMINARY PART- NOT RELEASED FOR PRODUCTION
- 7 0.25 [.010] RECESS PERMISSIBLE IN THIS AREA FOR MOLD SHUT OFF

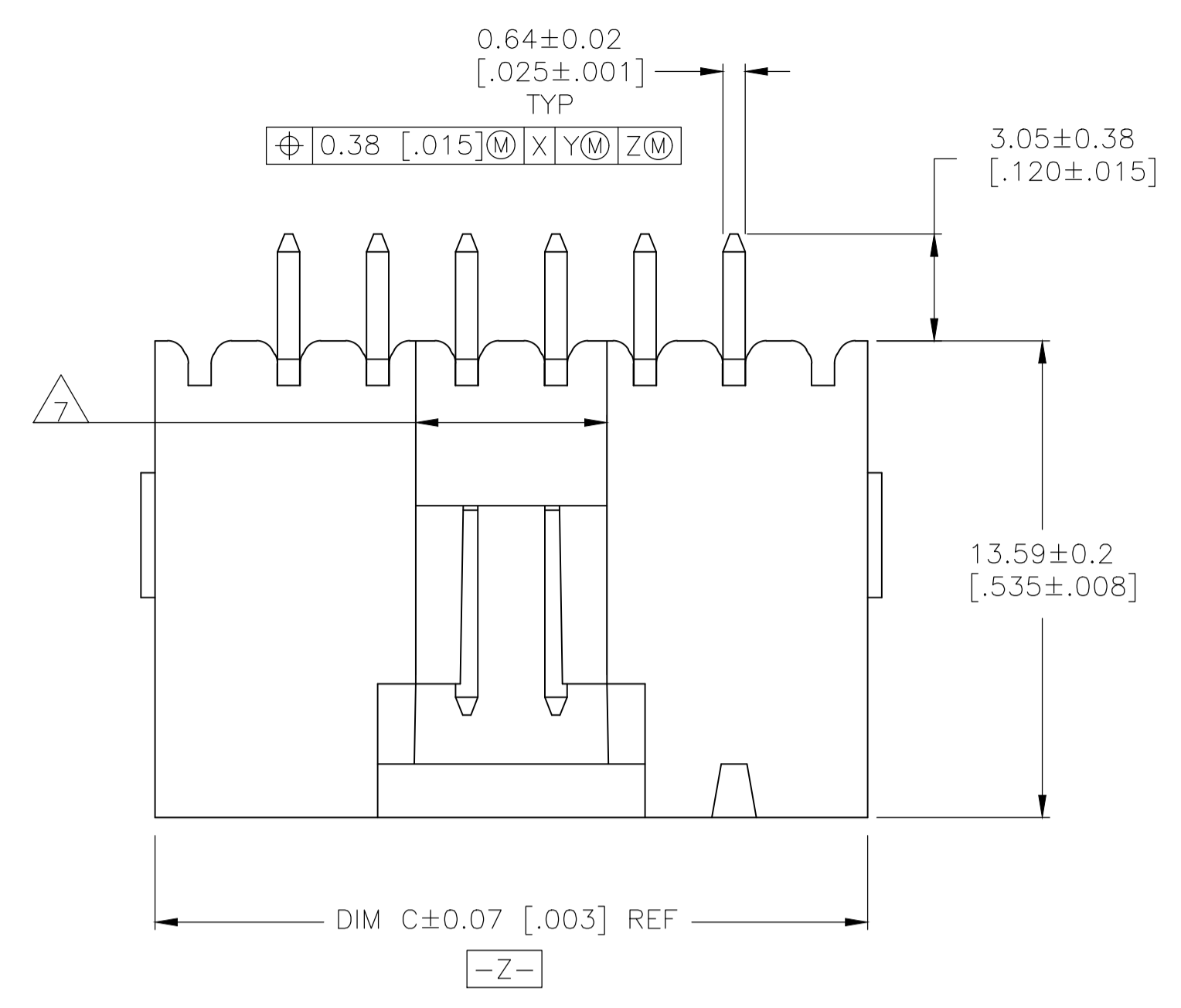
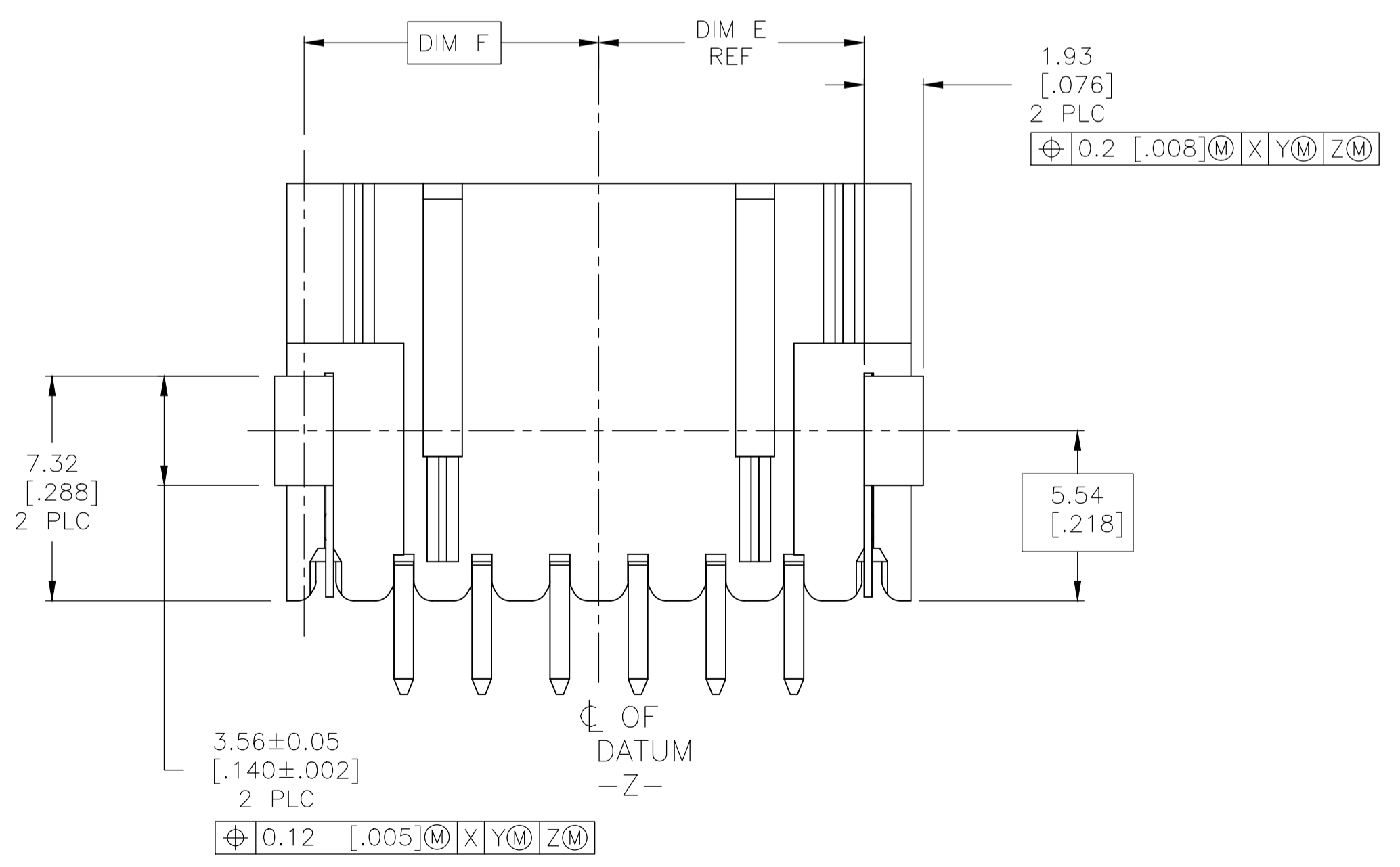
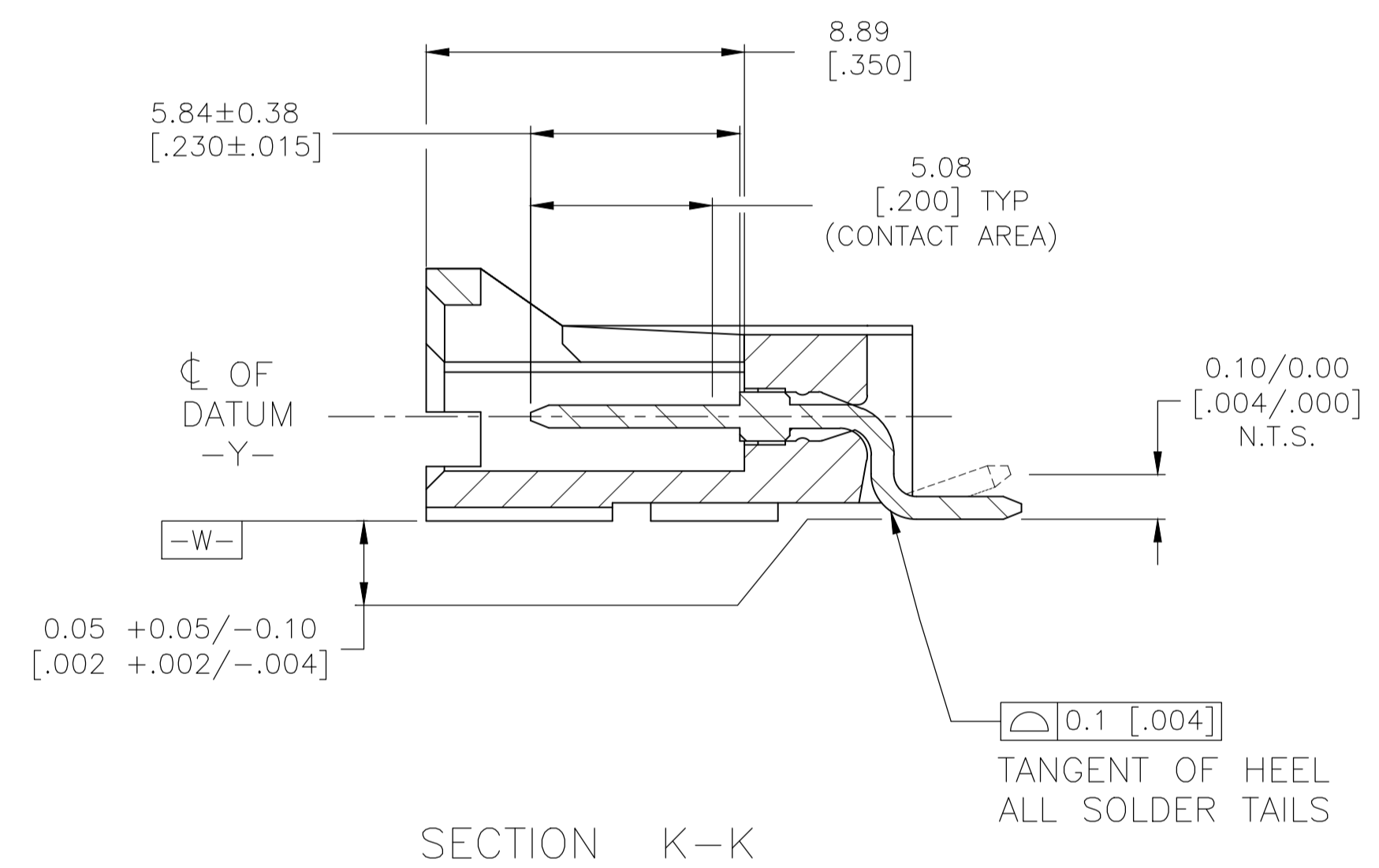
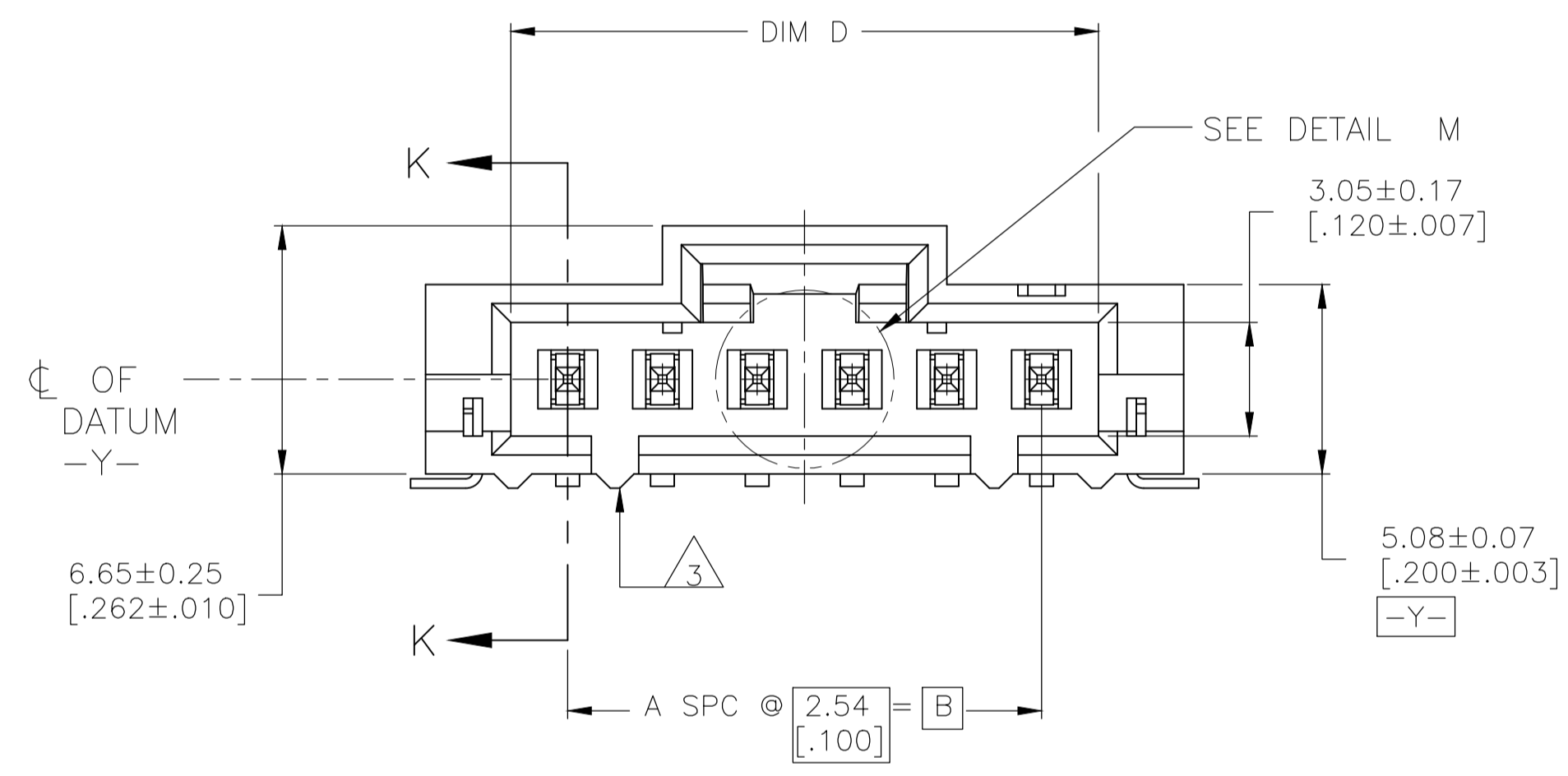

32	8.33 [.328]	7.37 [.290]	13.21 [.520]	17.78 [.700]	10.16 [.400]	4	5	1977162-5
72	23.58 [.928]	22.62 [.890]	43.72 [1.720]	48.30 [1.900]	40.67 [1.600]	16	17	1977162-4
72	21.04 [.828]	20.08 [.790]	38.64 [1.520]	43.21 [1.700]	13.59 [1.400]	14	15	1977162-3
56	18.51 [.728]	17.53 [.690]	33.55 [1.320]	38.13 [1.500]	30.50 [1.200]	12	13	1977162-2
44	9.60 [.378]	8.64 [.340]	15.76 [.620]	16.26 [.800]	12.70 [.500]	5	6	1977162-1
EIA 481 TAPE WIDTH mm	F	E	D	C	B	A	NO OF POSN	PART NUMBER

THIS DRAWING IS A CONTROLLED DOCUMENT.

DIMENSIONS: mm (INCHES)	TOLERANCES UNLESS OTHERWISE SPECIFIED:	APVD R BROWN 12JUL2007	NAME 108-25034
0 PLC ± -	1 PLC ± -	DATE 12JUL2007	PRODUCT SPEC
2 PLC ± -	3 PLC ± -	SIZE A1	APPLICATION SPEC
4 PLC ± 0.13 [.005]	ANGLES ± -	WEIGHT -	RESTRICTED TO

MATERIAL 1 FINISH 4

CUSTOMER DRAWING SCALE 6:1 SHEET 1 OF 2 REV C

STE TE Connectivity Ltd.

HEADER ASSEMBLY, LATCHING, RIGHT ANGLE SURFACE MOUNT, MTE, AMPMODU

REVISIONS				
P	LTR	DESCRIPTION	DATE	APPV
-		SEE SHEET 1	-	-

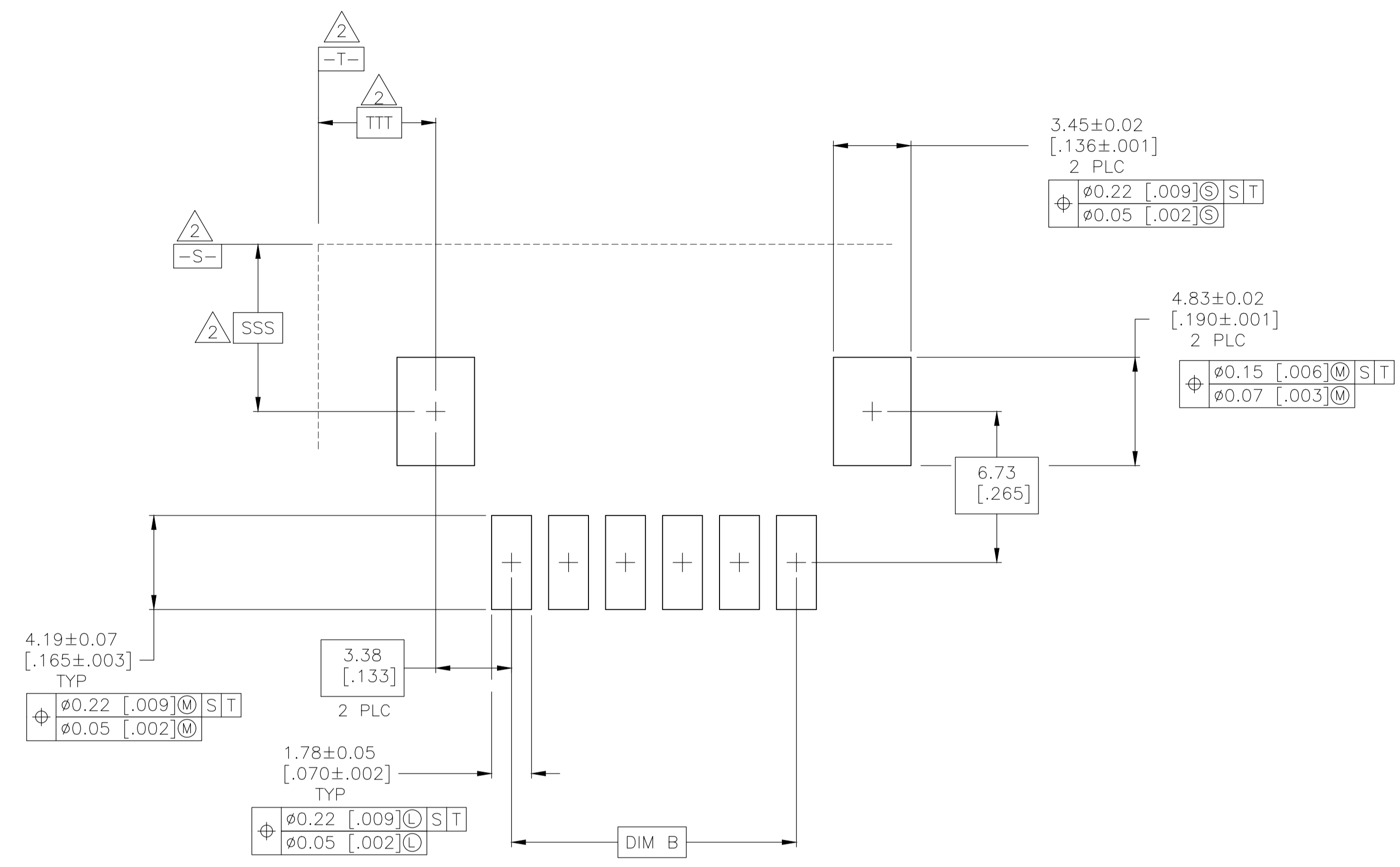

RECOMMENDED PC BOARD LAYOUT

THIS DRAWING IS A CONTROLLED DOCUMENT.		DIN R BROWN 12JUL2007	
		CHK R BROWN 12JUL2007	
		APPV R BROWN 12JUL2007	NAME
		PRODUCT SPEC	HEADER ASSEMBLY, LATCHING, RIGHT ANGLE SURFACE MOUNT, MTE, AMPMODU
		APPLICATION SPEC	108-25034
		SIZE	A1
		WEIGHT	00779 C=1977162
		CUSTOMER DRAWING	SCALE 6:1 SHEET 2 OF 2 REV C

单击下面可查看定价，库存，交付和生命周期等信息

[>>TE Connectivity\(泰科\)](#)