

1 VERPACKUNGSEINHEIT:

- | | | |
|--|---|---|
| <ul style="list-style-type: none"> -1 AMPLIMITE ABSCHIRMKAPPE -1 BUCHSENSTECKER AWG26-22 -2 MONTAGESCHRAUBEN M3 IN PLASTIKBEUTEL VERPACKT
PLASTIKBEUTEL MIT GEWINDEGRÖSSE "M3" BESCHRIFTET -2 MONTAGESCHRAUBEN 4-40 UNC IN PLASTIKBEUTEL VERPACKT
PLASTIKBEUTEL MIT GEWINDEGRÖSSE "4-40 UNC" BESCHRIFTET | } | <ul style="list-style-type: none"> - TEILE IN PLASTIKBEUTEL VERPACKT - PLASTIKBEUTEL MIT AMP BESTELL-NR. "966 778-1" UND SEL SACHNUMMER "3AV 10130 0002" BESCHRIFTET - 120 PLASTIKBEUTEL IN FALTSCHACHTEL VERPACKT |
|--|---|---|

2 VERPACKUNGSEINHEIT: 84 (MINDESTBESTELLMENGE)

- | | | |
|--|---|--|
| <ul style="list-style-type: none"> - 84 ABSCHIRMKAPPEN IN KARTONS VERPACKT -168 MONTAGESCHRAUBEN M3 IN PLASTIKBEUTEL VERPACKT
PLASTIKBEUTEL MIT GEWINDEGRÖSSE "M3" BESCHRIFTET -168 MONTAGESCHRAUBEN 4-40 UNC IN PLASTIKBEUTEL VERPACKT
PLASTIKBEUTEL MIT GEWINDEGRÖSSE "4-40 UNC" BESCHRIFTET -336 SCHRAUBEN FÜR KABELSCHELLE UND ABSCHIRMKAPPEN IN PLASTIKBEUTEL VERPACKT - 84 KABELSCHELLEN IN PLASTIKBEUTEL VERPACKT - 84 BUCHSENSTECKER IN TABLEAU VERPACKT | } | <ul style="list-style-type: none"> - TEILE IN UMKARTON VERPACKT - UMKARTON MIT AMP BESTELL-NR. "966 778-2" UND SEL SACHNUMMER "8AK 00003 2028" BESCHRIFTET |
|--|---|--|

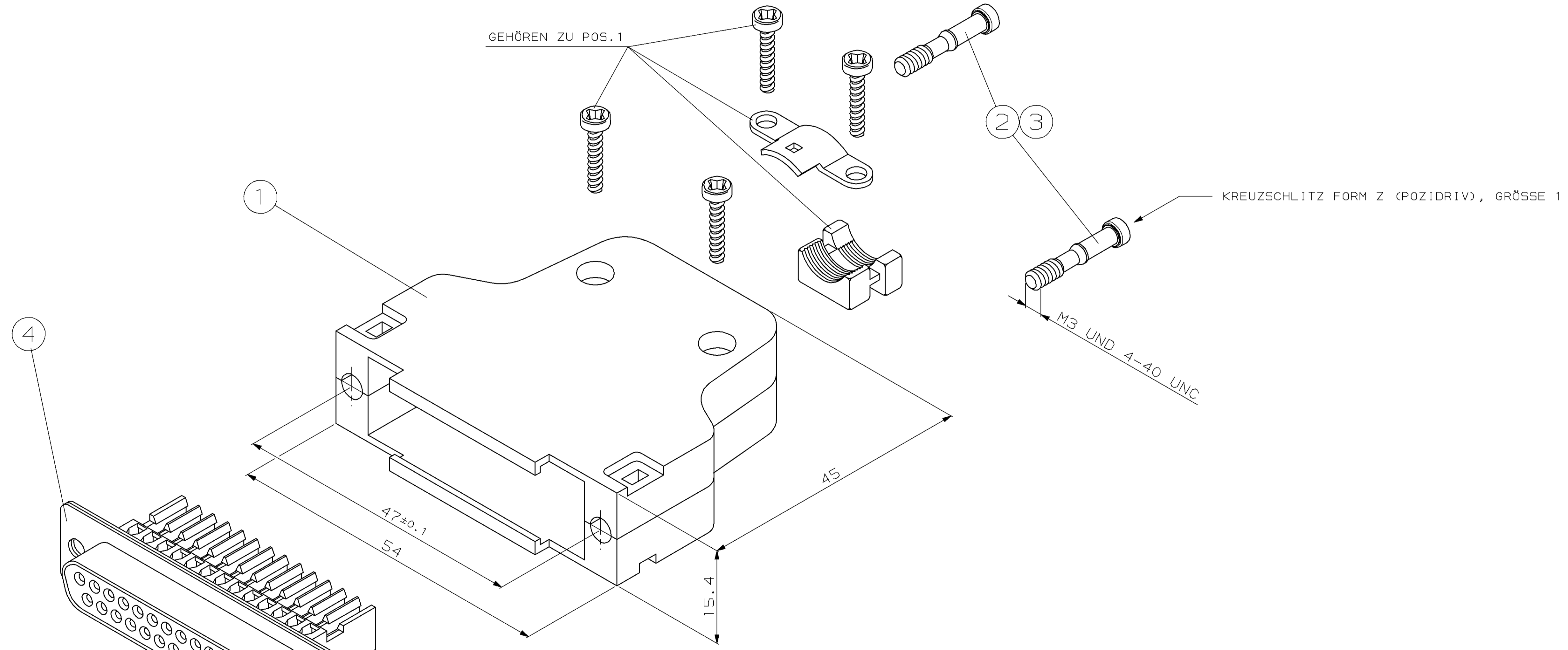

1 RÜCKSEITE (KAMMER 1) DES METALLKÖRPERS MIT G E L B E M FARBUNKT (MIN. ø2mm) MARKIERT

POS.	STOCK	BENENNUNG EINZELTEIL	AMP-PN	WERKSTOFF	FARBE
4	1	BUCHSENSTECKER AWG26-22	745 495-2	-	KONTAKTBREICH 0,8µm Au OBER NI
3	2	MONTAGESCHRAUBE 4-40 UNC	-	STAHL	E2J DIN 267
2	2	MONTAGESCHRAUBE M3	-	STAHL	E2J DIN 267
1	1	AMPLIMITE ABSCHIRMKAPPE	-	ZINK-DRUCKGUSS	10-12µm NI OBER 5-8µm Cu
4	1	BUCHSENSTECKER AWG26-22	745 495-2	-	KONTAKTBREICH 0,8µm Au OBER NI
3	2	MONTAGESCHRAUBE 4-40 UNC	-	STAHL	E2J DIN 267
2	2	MONTAGESCHRAUBE M3	-	STAHL	E2J DIN 267
1	1	AMPLIMITE ABSCHIRMKAPPE	-	ZINK-DRUCKGUSS	10-12µm NI OBER 5-8µm Cu

<p>THIS DRAWING IS UNCLASSIFIED... IT IS SUBJECT TO CHANGE AND THE CONTROLLING ENGINEERING DEPARTMENT SHALL BE CONTACTED FOR THE LATEST REVISION.</p>		<p>DATE: 16-FEB-98 UIN: I. SCHERZER APVD: R. KRÄMER</p>
<p>OTHERWISE SPECIFIED, ALL DIMENSIONS ARE IN MILLIMETERS UNLESS OTHERWISE SPECIFIED.</p>		<p>DATE: 16-FEB-98 UIN: G. FELDMEIER APVD: G. FELDMEIER</p>
<p>APPLIMITE-ABSCHIRMKAPPEN KIT (STANDARD MONTAGE - BAUGRÖSSE 3)</p>		<p>AMP Deutschland GmbH D - 63225 Langen</p>
<p>SIZE: A1 CAGE CODE: 00779 DRAWING NO: 966778</p>		<p>RESTRICTED TO: AMP FÜR CUSTOMER DRAWING /KUNDENZEICHNUNG</p>

单击下面可查看定价，库存，交付和生命周期等信息

[>>TE Connectivity\(泰科\)](#)