

THIS DRAWING IS UNPUBLISHED. RELEASED FOR PUBLICATION
 © COPYRIGHT - By - ALL RIGHTS RESERVED.

REVISIONS					
P	LTR	DESCRIPTION	DATE	DWN	APVD
Y1		REVISED PER ECO-16-009170	20JUN2016	NK	DR

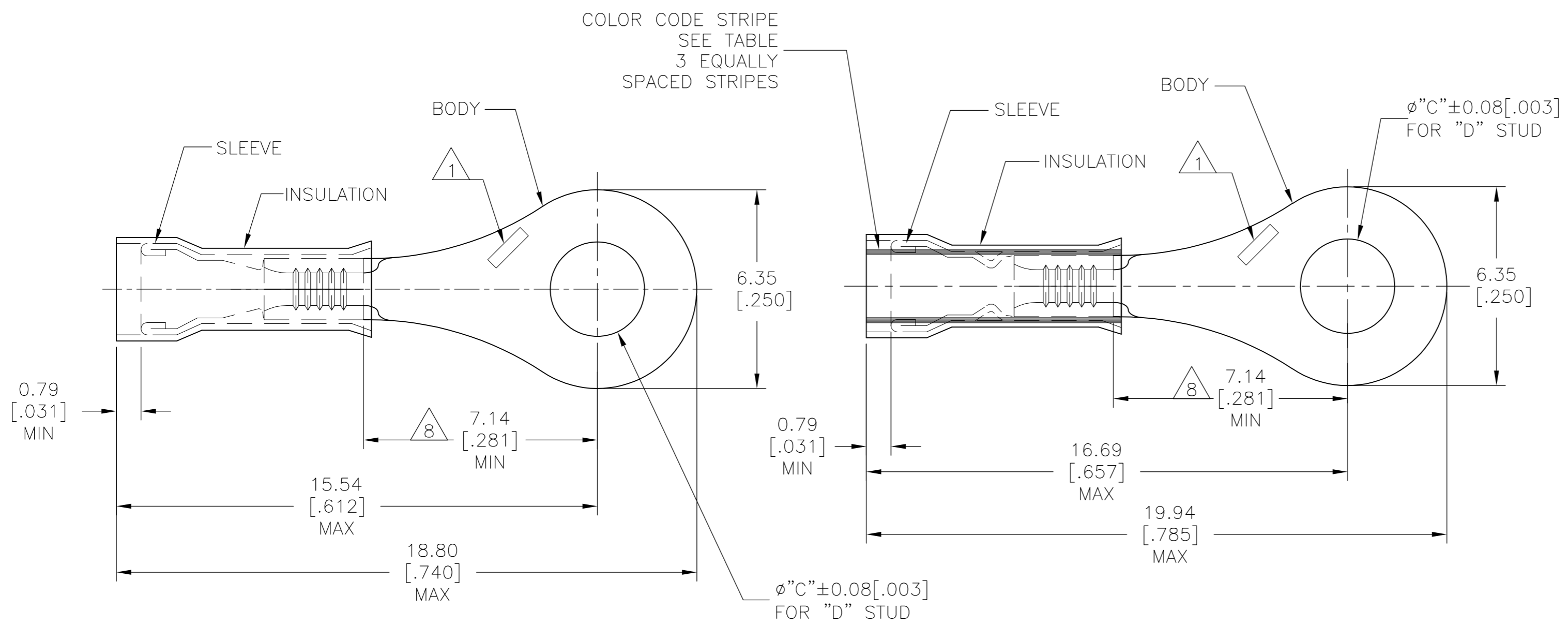

STYLE A

STYLE B
INSULATION RESTRICTING

- 1 STAMP "AMP", APPROX AS SHOWN.
- 2 WIRE INSULATION DIA: SEE TABLE.
- 3 TONGUE MATERIAL THK: 0.46±0.05[.018±.002].
- 4 BODY & SLEEVE: CU PER ASTM B152
INSULATION: NYLON PER ASTM D4066, COLOR - YELLOW.
- 5 BODY: TIN PLATE 0.00254[.000100] MIN EXT THK PER ASTM B545.
- 6 SLEEVE: TIN PLATE 0.00254[.000100] MIN THK PER ASTM B545.
- 7 SLEEVE: NICKEL PLATE PER SAE AMS QQ-N-290.
- 8 APPLIES FROM EDGE OF METAL WIRE BARREL TO CENTER OF STUD HOLE.
- 9 MEETS MS25036-145, CLASS 2.
- 10 NOTE DELETED.

0.10-0.41mm ² [202-810CMA]	100	LOOSE PIECE, BOX	M3.5[#6]	3.68[.145]	1.27-2.08[.050-.082]	26-22	--	A		6		8-326875-1	
0.24mm ² [475CMA]	500	LOOSE PIECE	#10	5.00[.197]	0.79-1.40[.031-.055]	24	BLUE	B	5	7	4	2-326875-5	
	500	LOOSE PIECE	M3.5[#6]	3.68[.145]	0.79-1.40[.031-.055]	24	BLUE	B				2-326875-4	
0.10-0.41mm ² [202-810CMA]	4000	326875 ON TAPE, REEL	M3.5[#6]	3.68[.145]	1.27-2.08[.050-.082]	26-22	--	A	6	9	9	2-326875-1	
	500	LOOSE PIECE	M3.5[#6]	3.68[.145]	1.27-2.08[.050-.082]	26-22	--	A				326875	
CIRCULAR MIL AREA	QTY	PACKAGE TYPE	STUD SIZE "D"	DIM "C"	WIRE INSUL. DIA	WIRE SIZE	COLOR CODE	STYLE	BODY	SLEEVE	MATERIAL	PART NO	
										FINISH			

AMP INCORPORATED
CUSTOMER SERVICE SYSTEMS

FOR ADDITIONAL PRODUCT INFORMATION OR COPIES OF DRAWINGS AND TECHNICAL DOCUMENTS: PRODUCT INFORMATION CENTER 1-800-522-6752

FOR APPLICATION TOOLING INFORMATION: TOOLING ASSISTANCE CENTER 1-800-722-1111

FOR ORDER ENTRY: 1-800-526-5142

MAX RECOMMENDED OPERATING TEMPERATURE: 105°C[221°F] MAX

VOLTAGE RATING: 300V MAX

CIRCULAR MIL AREA RANGE: SEE TABLE

THIS DRAWING IS A CONTROLLED DOCUMENT.

DWN: JR RUTH 14JAN10
 CHK: TOM MICHIELUTTI 14JAN10
 APVD: MIKE PERCHERKE 14JAN10

TE Connectivity

NAME: TERMINAL, NYLON - PIDG - RING TONGUE
 WIRE SIZE: 26-22

SIZE: A2 CAGE CODE: 00779 DRAWING NO: C=326875 RESTRICTED TO: -

SCALE: 8:1 SHEET: 1 OF 1 REV: Y1

CUSTOMER DRAWING

单击下面可查看定价，库存，交付和生命周期等信息

[>>TE Connectivity\(泰科\)](#)