

THIS DRAWING IS UNPUBLISHED. RELEASED FOR PUBLICATION
 © COPYRIGHT - By - ALL RIGHTS RESERVED.

LOC	DIST	REVISIONS			
P	LTR	DESCRIPTION	DATE	DWN	APVD
AF	50	E	REVISED PER ECR-12-013486	08JAN13	KH KR

SUGGESTED MATING TAB

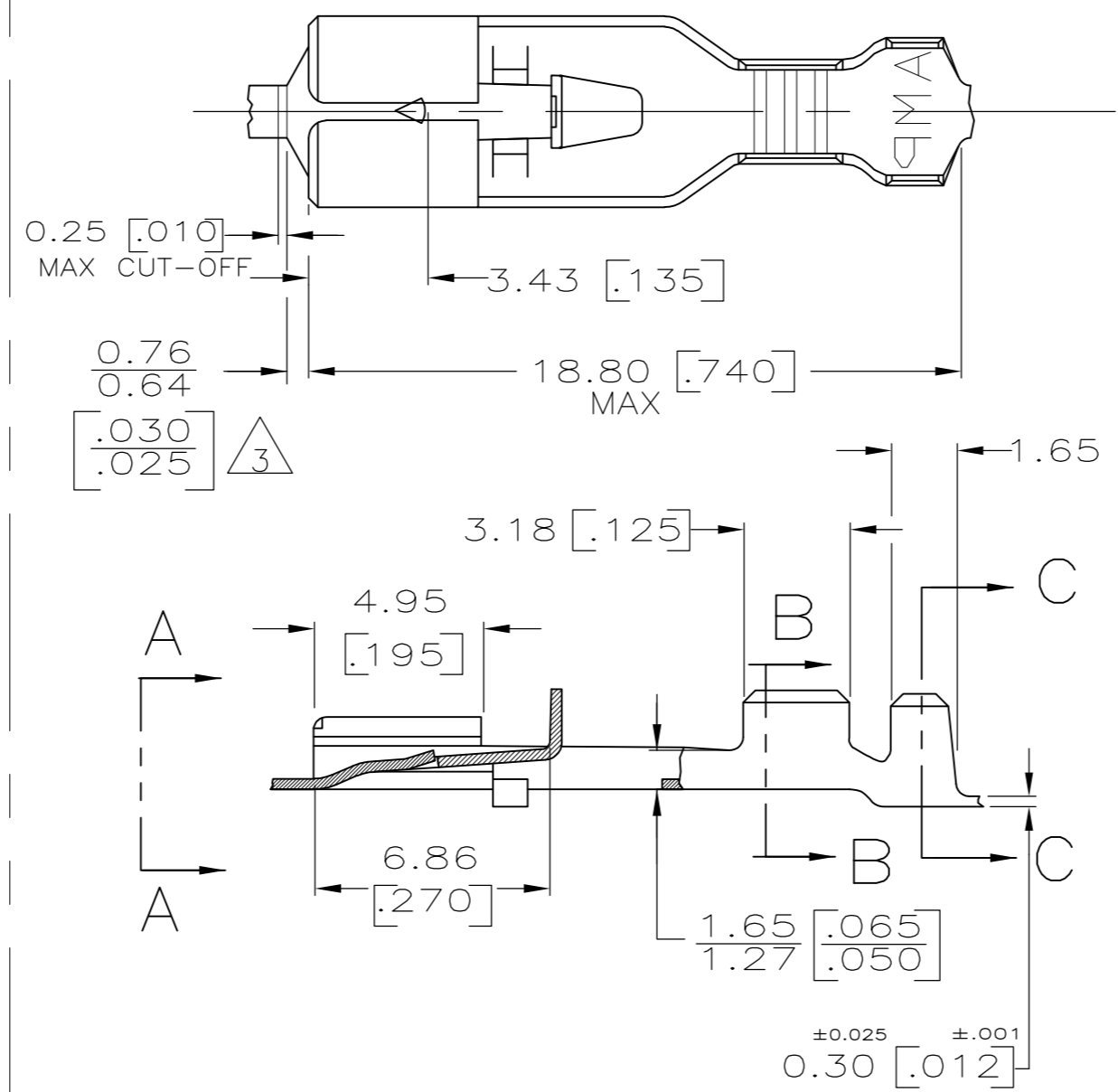
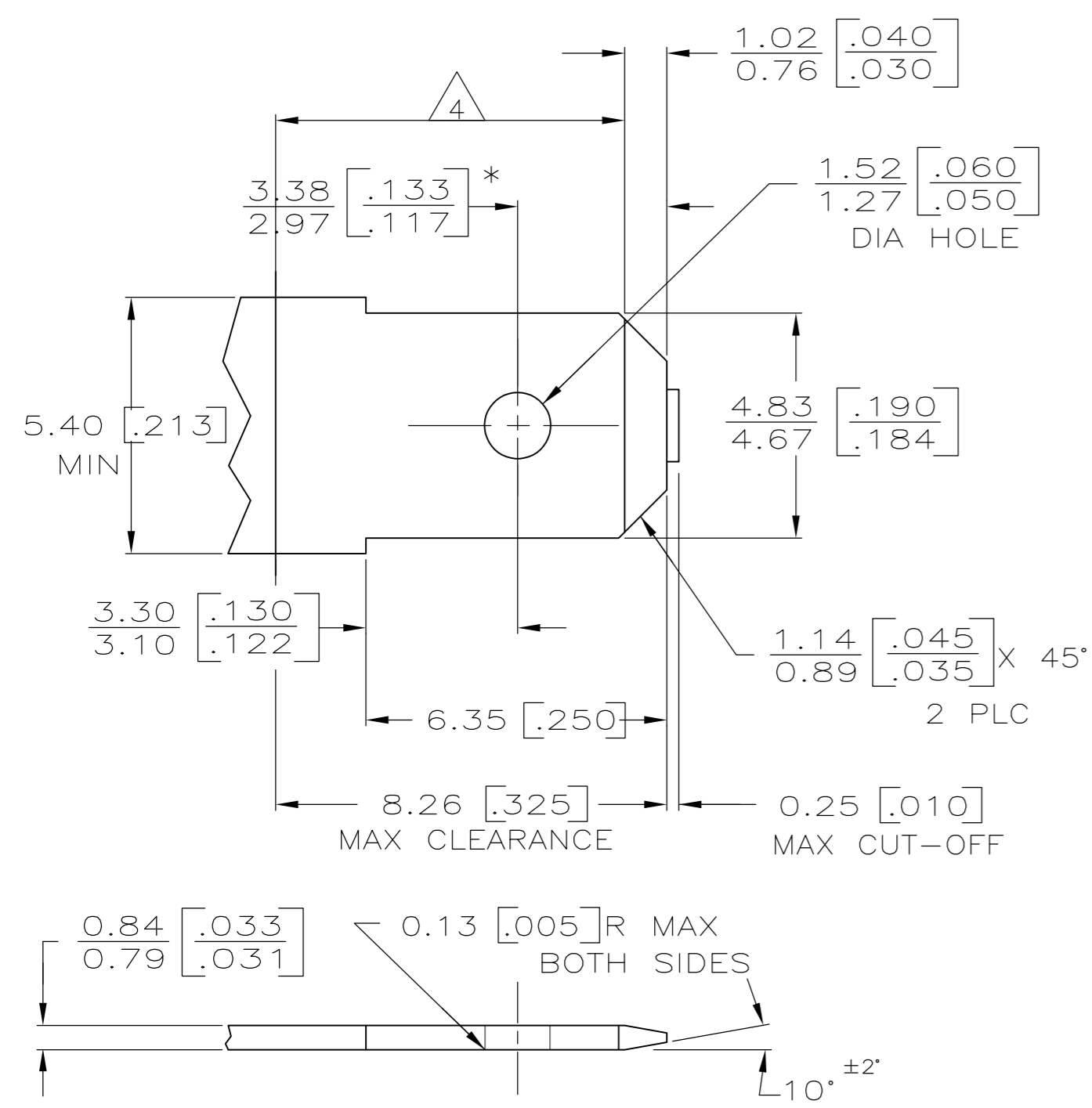

- 1 DIMENSIONS IN BRACKETS ARE IN INCHES.
- 2 CONTINUOUS STRIP ON REELS.
- 3 THIS DIMENSIONS MUST BE MAINTAINED FOR PROPER FUNCTION OF THE LATCHING MECHANISM.
- 4 WIRE SIZE IS 0.5-1.4mm [20-16] AWG
- 5 INSULATION RANGE IS 1.52-2.79 [.060-.110] DIA

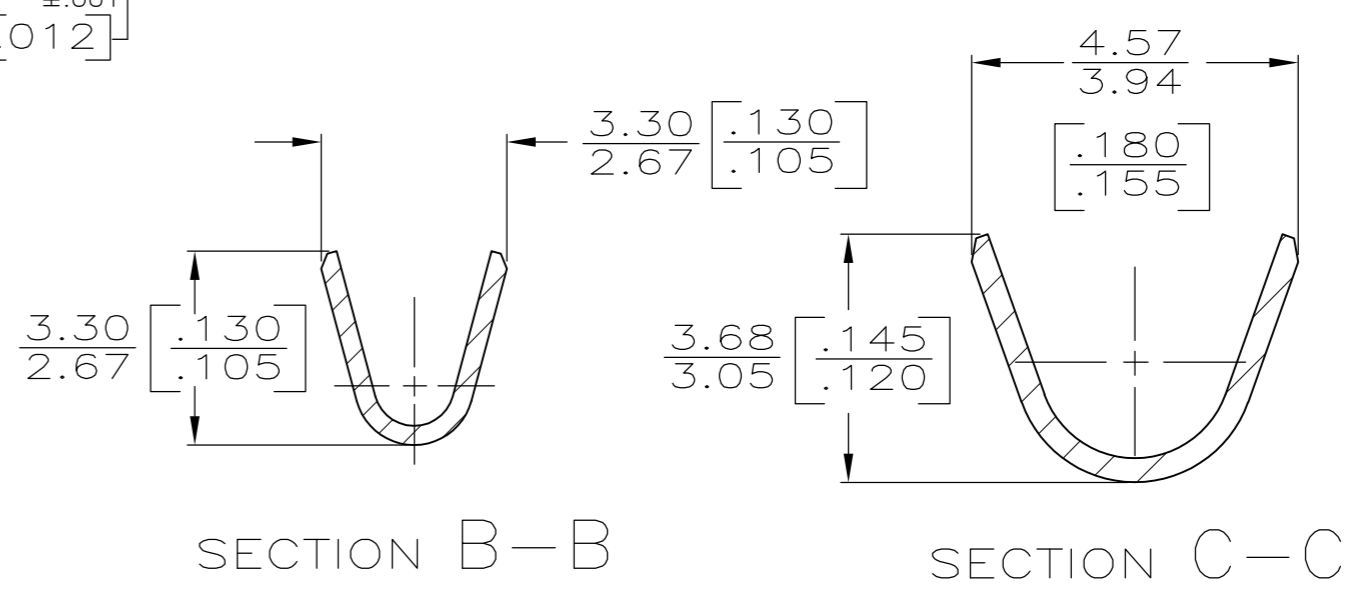
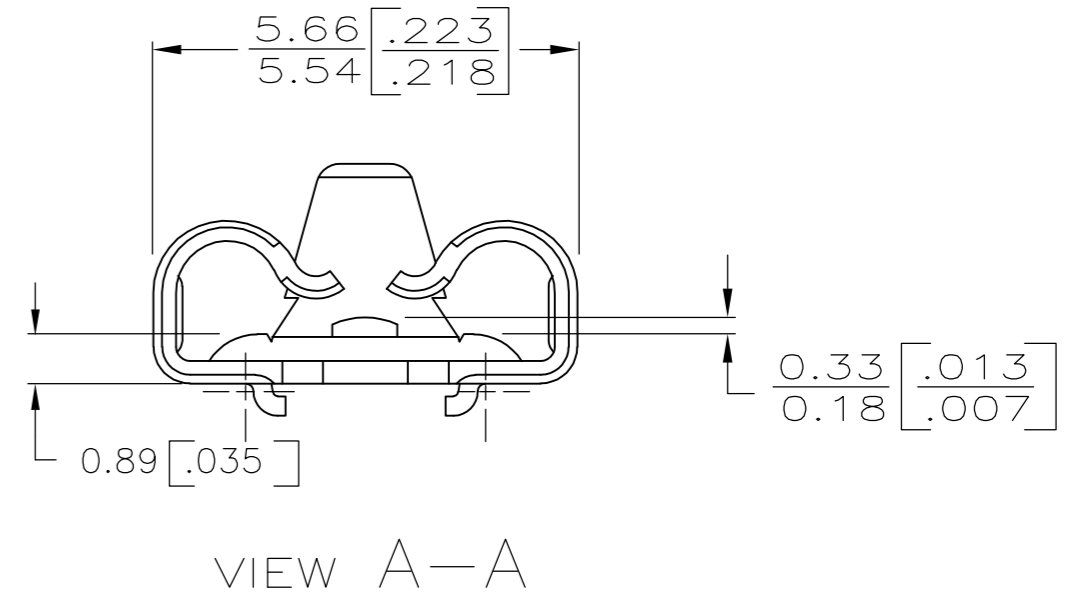

- 1 MATL: #2 HARD BRASS OR NICKEL PLATED STEEL.
 - 2 NO BURRS PERMISSIBLE AT HOLE.
 - 3 TIN PLATING IS REQUIRED ON BRASS WHEN TERMINAL TEMPERATURE IS OVER 225°F
 - 4 MUST BE FLAT WITHIN 0.076 [.003] OVER THIS LENGTH.
 - 5 HOLE MUST BE SYMMETRICAL ABOUT TAB CENTER WITHIN 0.076 [.003].
- * TO BE USED ONLY WHEN SHOULDER IS ELIMINATED.

F OR O	3.56 [.140]	4.78 [.188]	F	2.29 [.090]	1.448 [.057]	1.3mm [.16]
					1.27 [.050]	0.8mm [.18]
					1.143 [.045]	0.5mm [.20]
TYPE	WIDTH	STRIP LENGTH ±.015	TYPE	WIDTH	±.051 [±.002] HEIGHT	WIRE
INSUL BARREL CRIMP			WIRE BARREL CRIMP			

-	63498-2
TIN	63498-1
FINISH	PART NO.

THIS DRAWING IS A CONTROLLED DOCUMENT.		DWN	JR RUTH	10/12/89	 TE Connectivity
DIMENSIONS: mm [INCHES]		CHK	MS FEHER	10/12/89	
TOLERANCES UNLESS OTHERWISE SPECIFIED:		APVD	R KUZO	10/12/89	
0 PLC ± - 1 PLC ± - 2 PLC ± - 3 PLC ± 0.25 [.010] 4 PLC ± - ANGLES ± - FINISH SEE TABLE		PRODUCT SPEC			
MATERIAL: BRASS		APPLICATION SPEC	RECEPTACLE, POSITIVE LOCK, 4.75 [.187] SERIES		RESTRICTED TO
CUSTOMER DRAWING		WEIGHT	-	SCALE: 5:1	SHEET: 1 OF 1
		SIZE	A2	CAGE CODE	00779
		DRAWING NO	C=63498		REV: E

单击下面可查看定价，库存，交付和生命周期等信息

[>>TE Connectivity\(泰科\)](#)