

LOC		DIST		REVISIONS				
AD	00	REV	PER	ECO	NO	DATE	BY	APP'D
D1		REV PER	ECO-07-002646			02MAR2007	BC	RP

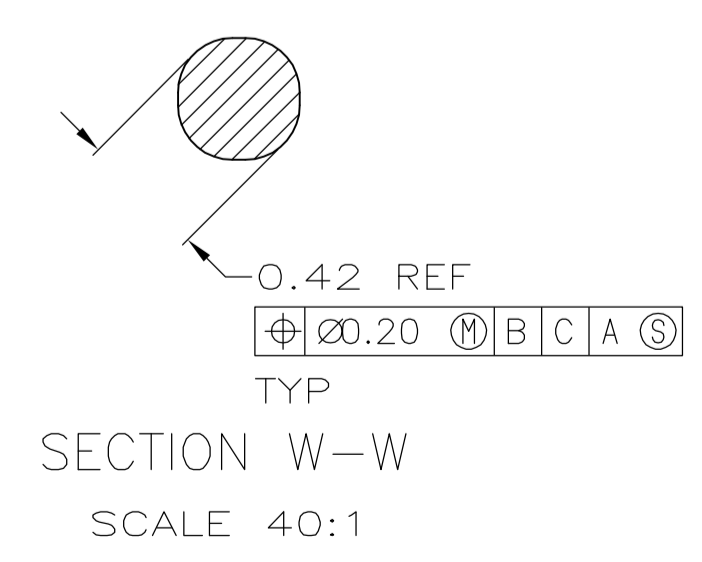

- 1 MATERIAL: HOUSING: POLYESTER. COLOR: GREY. UL 94V-0. CONTACT: PHOSPHOR BRONZE.
- 2 FINISH: CONTACT MATING AREA: 1.27µm MIN GOLD OR 0.08µm MIN GOLD OVER 0.76µm MIN PALLADIUM-NICKEL. ACTION PIN AREA: 0.5µm MIN TIN LEAD PLATE, ALL OVER 1.27µm MIN NICKEL UNDERPLATE.
- 3 FINISH: CONTACT LUBRICATION WITH BELLCORE APPROVED LUBRICANT. TECHNICAL REFERENCE: TR-NWT-001217 ISSUE 1, SEPT 1992.
- 4 DIMENSION APPLIES AFTER CONNECTOR IS APPLIED TO P.C. BOARD.
- 5 REFERENCE APPLICATION SPEC 114-1103 FOR RECOMMENDED PLATED THRU HOLE DIAMETER AND PLATING THICKNESSES.
- 6 CURRENT RATING 10A/CONTACT PER PRODUCT SPEC 108-1651.

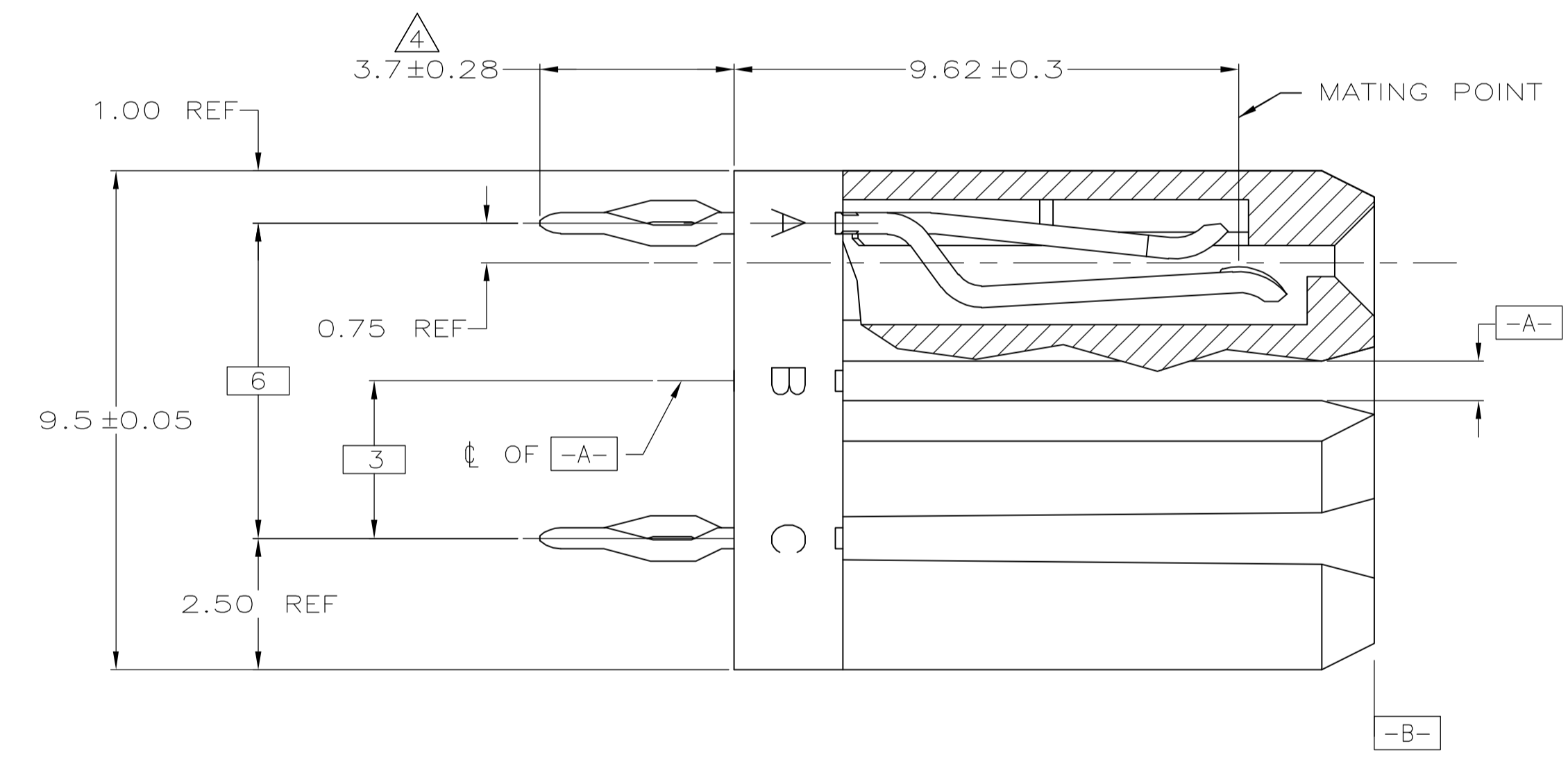
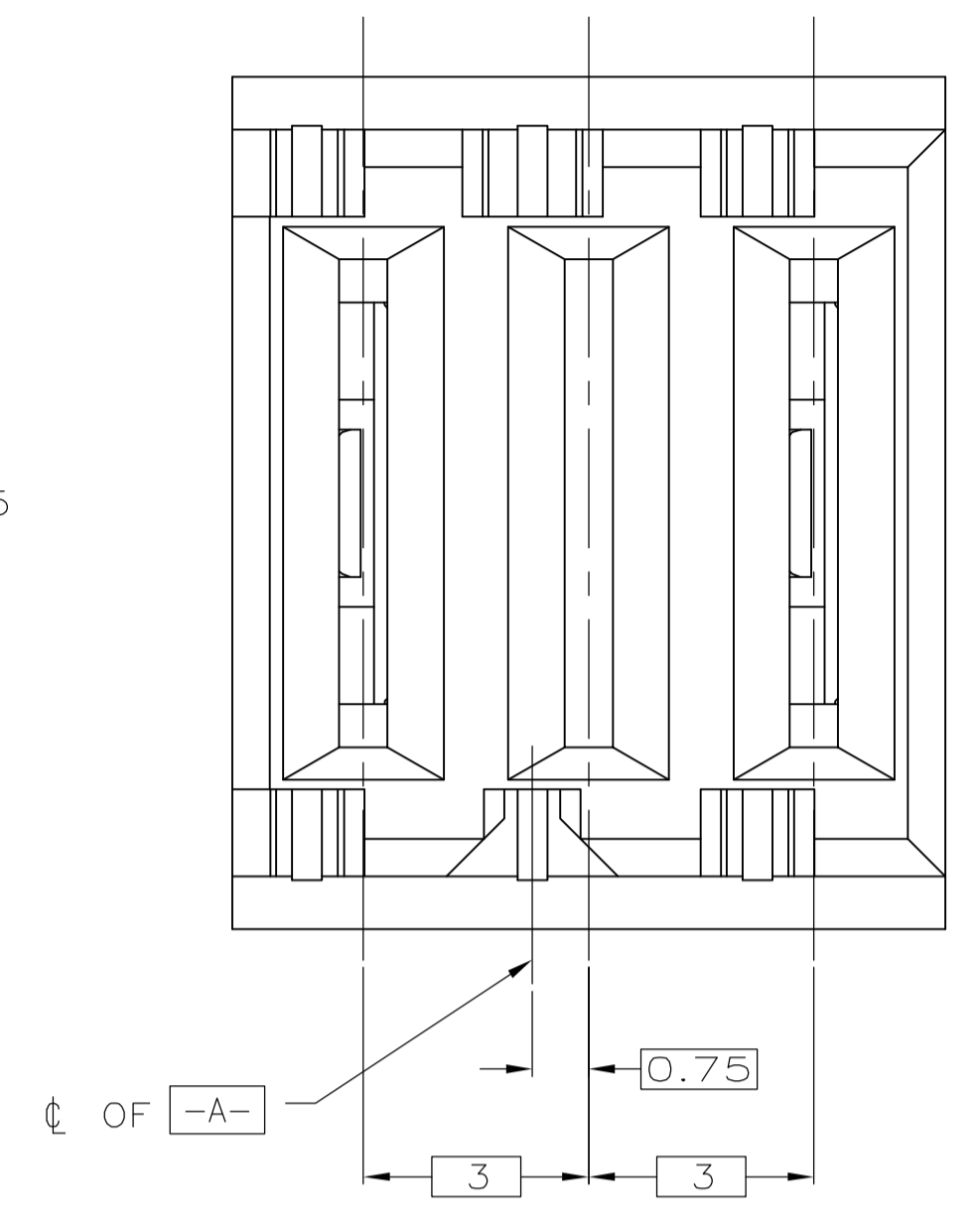
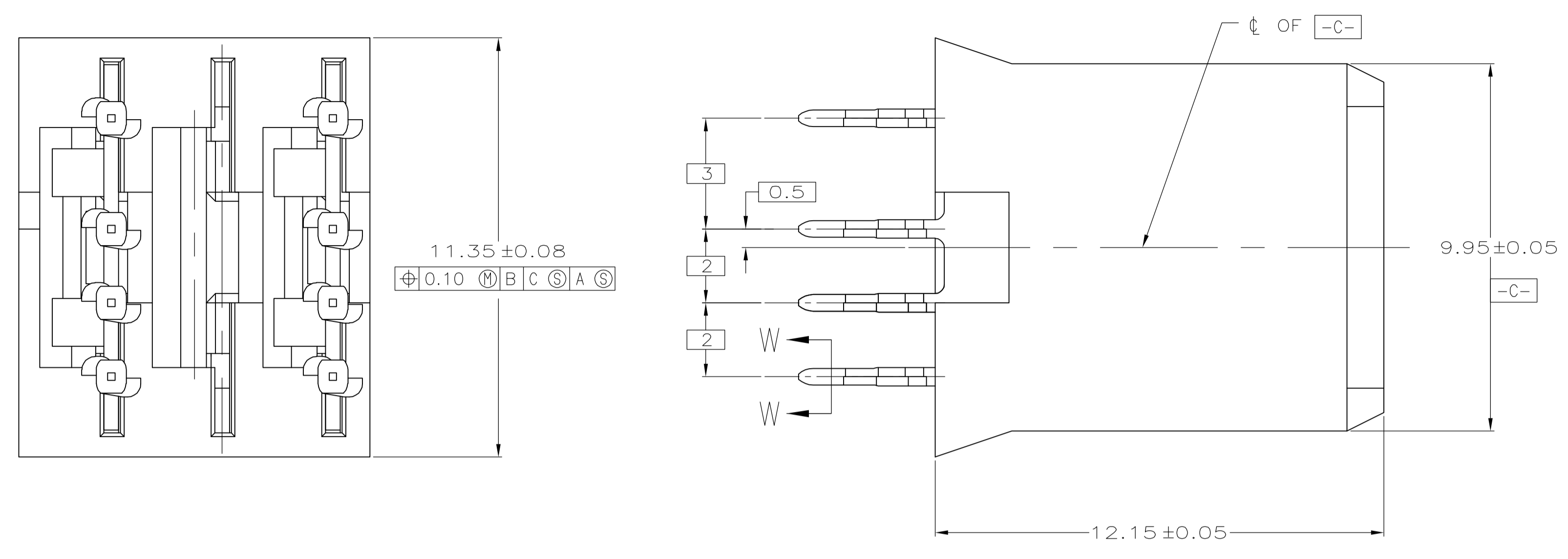
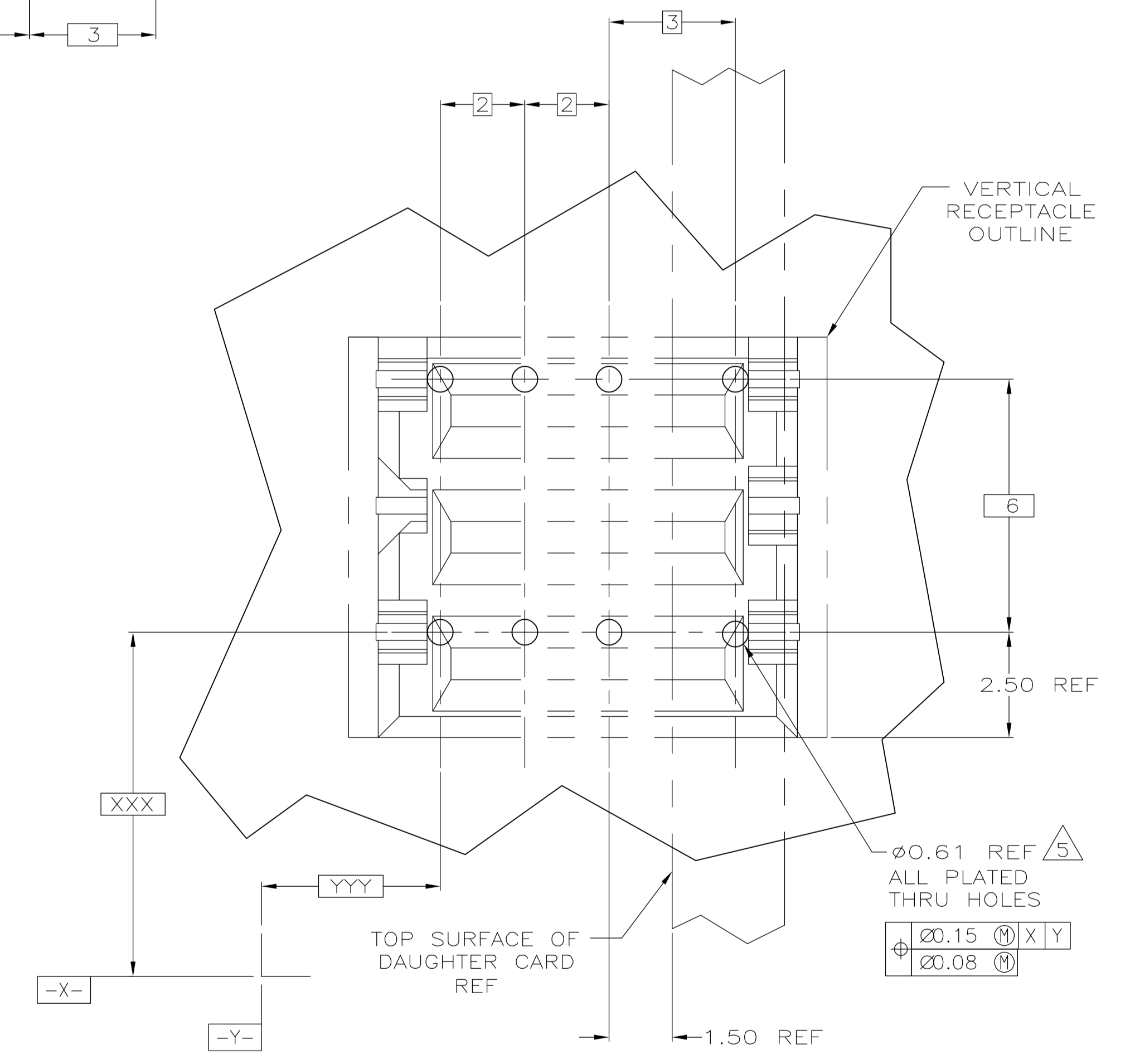

RECOMMENDED PCB HOLE LAYOUT

223984-1
PART NUMBER

THIS DRAWING IS A CONTROLLED DOCUMENT.		DWG: T. SHUEY 12-11-98		Tyco Electronics Corporation Harrisburg, PA 17105-3608	
DIMENSIONS: mm		CHK: R. PATTERSON 12-11-98		NAME: R. PATTERSON 12-11-98	
TOLERANCES UNLESS OTHERWISE SPECIFIED:		PRODUCT SPEC		APPLICATION SPEC	
0 PLC ± - 1 PLC ± - 2 PLC ± 0.13 3 PLC ± - 4 PLC ± - ANGLES ± -		SIZE: A1		CAGE CODE: 00779	
MATERIAL: 1		FINISH: 2, 3		DRAWING NO: 223984	
CUSTOMER DRAWING		SCALE: 10:1		SHEET: 1 OF 1	

单击下面可查看定价，库存，交付和生命周期等信息

[>>TE Connectivity\(泰科\)](#)