

THIS DRAWING IS UNPUBLISHED. RELEASED FOR PUBLICATION
 © COPYRIGHT BY TYCO ELECTRONICS CORPORATION. ALL RIGHTS RESERVED.

LOC	DIST	REVISIONS					
AJ	00	P	LTR	DESCRIPTION	DATE	DWN	APVD
		B		REV PER ECO 06-006349	21MAR2007	DW	KW

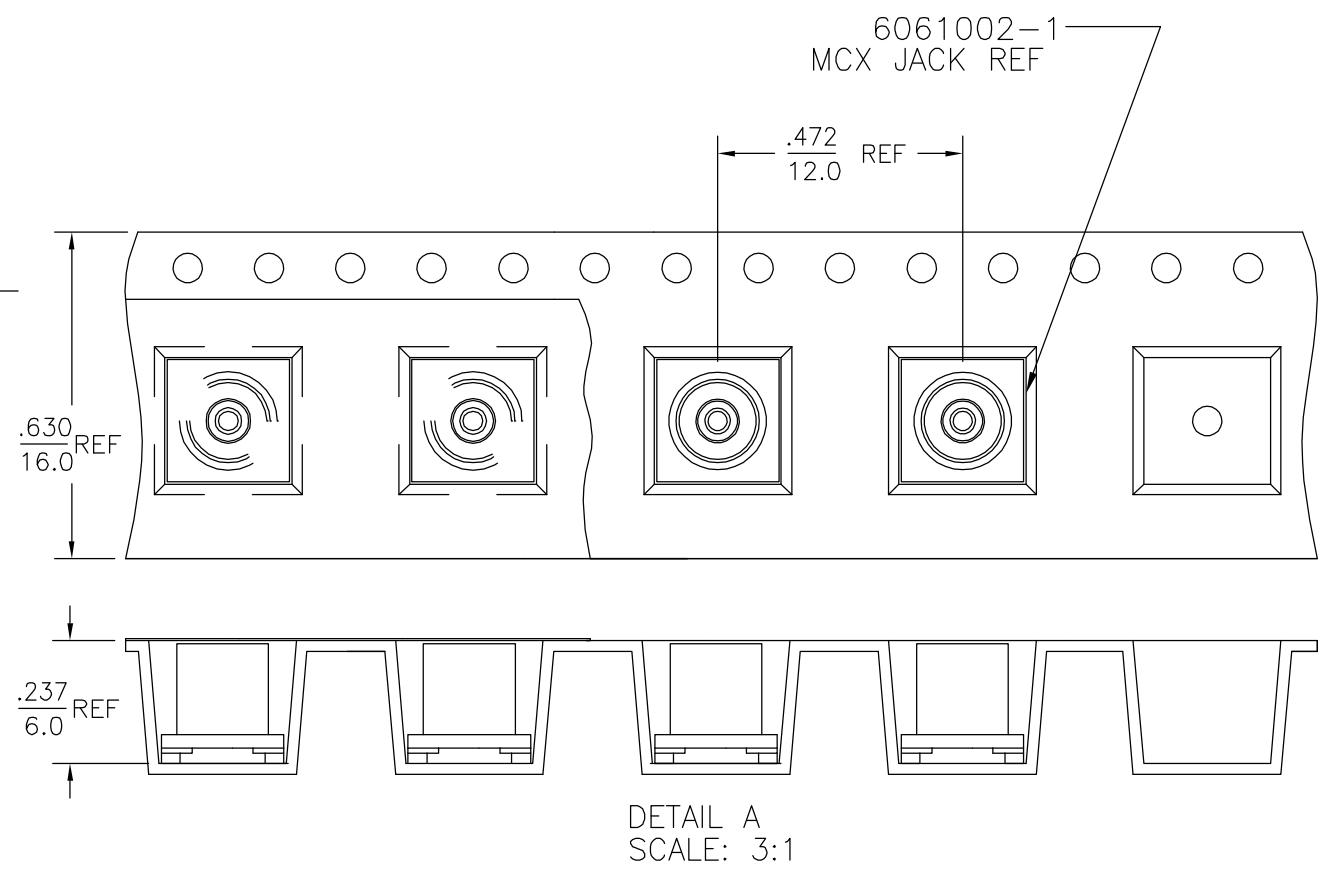
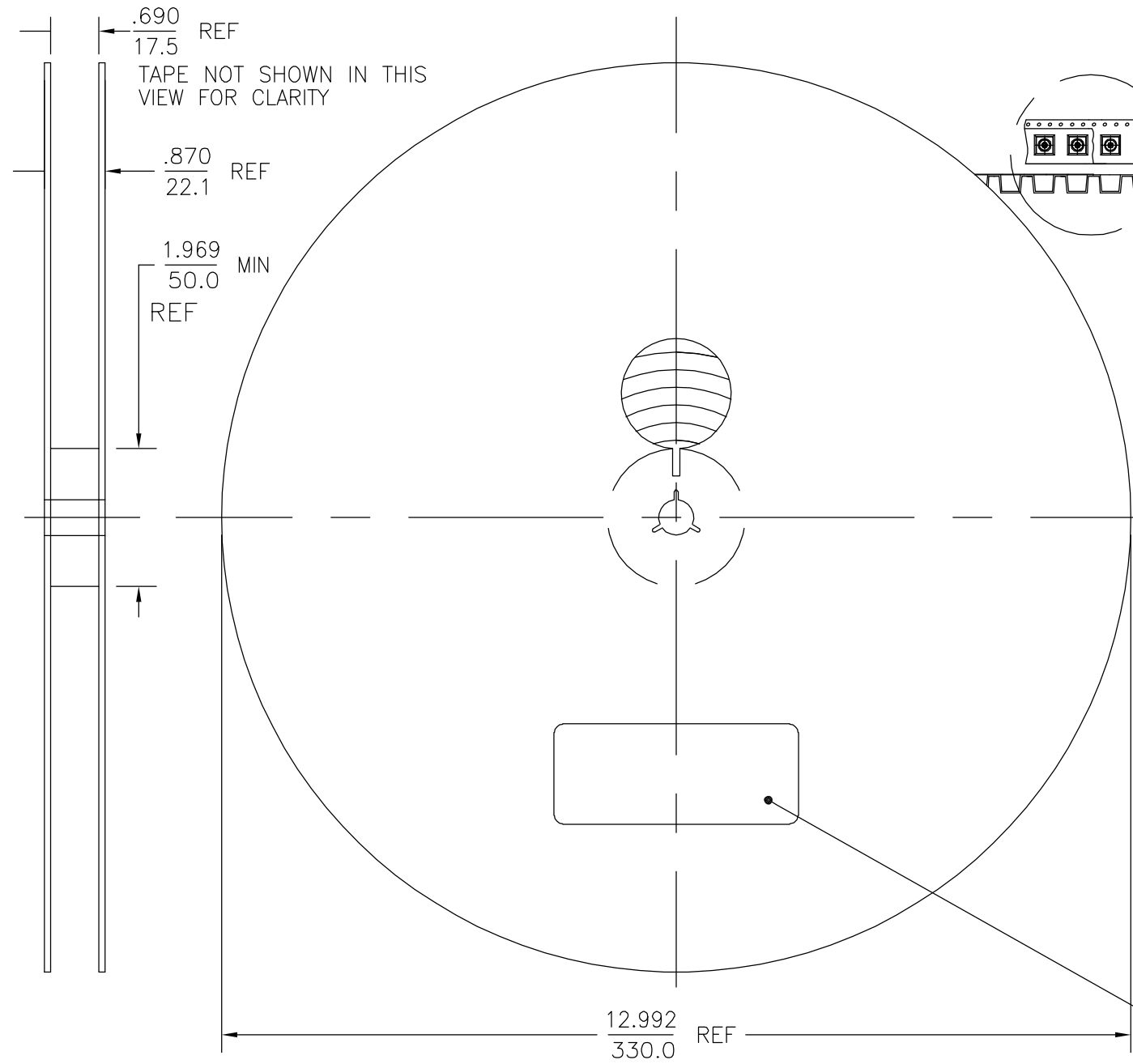

REEL IDENTIFICATION LABEL REF (SEE NOTE 5)

1. TAPE, REEL, AND TAPING SHALL MEET THE REQUIREMENTS OF EIA-481-2.
2. EMBOSSED TAPE SHALL BE CONDUCTIVE TYPE.
3. FOR PART ORIENTATION IN TAPE SEE DETAIL A.
4. REEL SHALL CONTAIN 900 PIECES P/N 6061002-1
5. REEL IDENTIFICATION LABEL SHALL BE PRINTED WITH REEL P/N, CONNECTOR P/N, MANUFACTURER QTY, AND TAPING DATE AS A MINIMUM.

6061092-1
PART NUMBER

THIS DRAWING IS A CONTROLLED DOCUMENT.		DWN L. VARELA - DOCK5 01FEB2005	tyco Electronics Tyco Electronics Corporation Harrisburg, PA 17105-3608	
DIMENSIONS: INCHES [mm]		CHK J. HAVENER 01FEB2005	NAME	
TOLERANCES UNLESS OTHERWISE SPECIFIED:		APVD K. WEIDNER 01FEB2005	TAPE & REEL PACKAGING MCX JACK, 330mm REEL (900 PARTS PER REEL) (5899-5004-54)	
0 PLC ± -		PRODUCT SPEC	SIZE	CAGE CODE
1 PLC ± -		APPLICATION SPEC	A3	00779
2 PLC ± -		WEIGHT	DRAWING NO C-6061092	
3 PLC ± -			RESTRICTED TO	
4 PLC ± -			-	
ANGLES ± 1°			SCALE	SHEET
FINISH			1:2	1 OF 1
MATERIAL			REV B	
-		CUSTOMER DRAWING		

单击下面可查看定价，库存，交付和生命周期等信息

[>>TE Connectivity\(泰科\)](#)