

LOC		DIST		REVISIONS			
GP	00	REV	PER	EC	DATE	BY	APPROV
0		REV PER EC	0513-0016-05		04-14-05	JA	JG

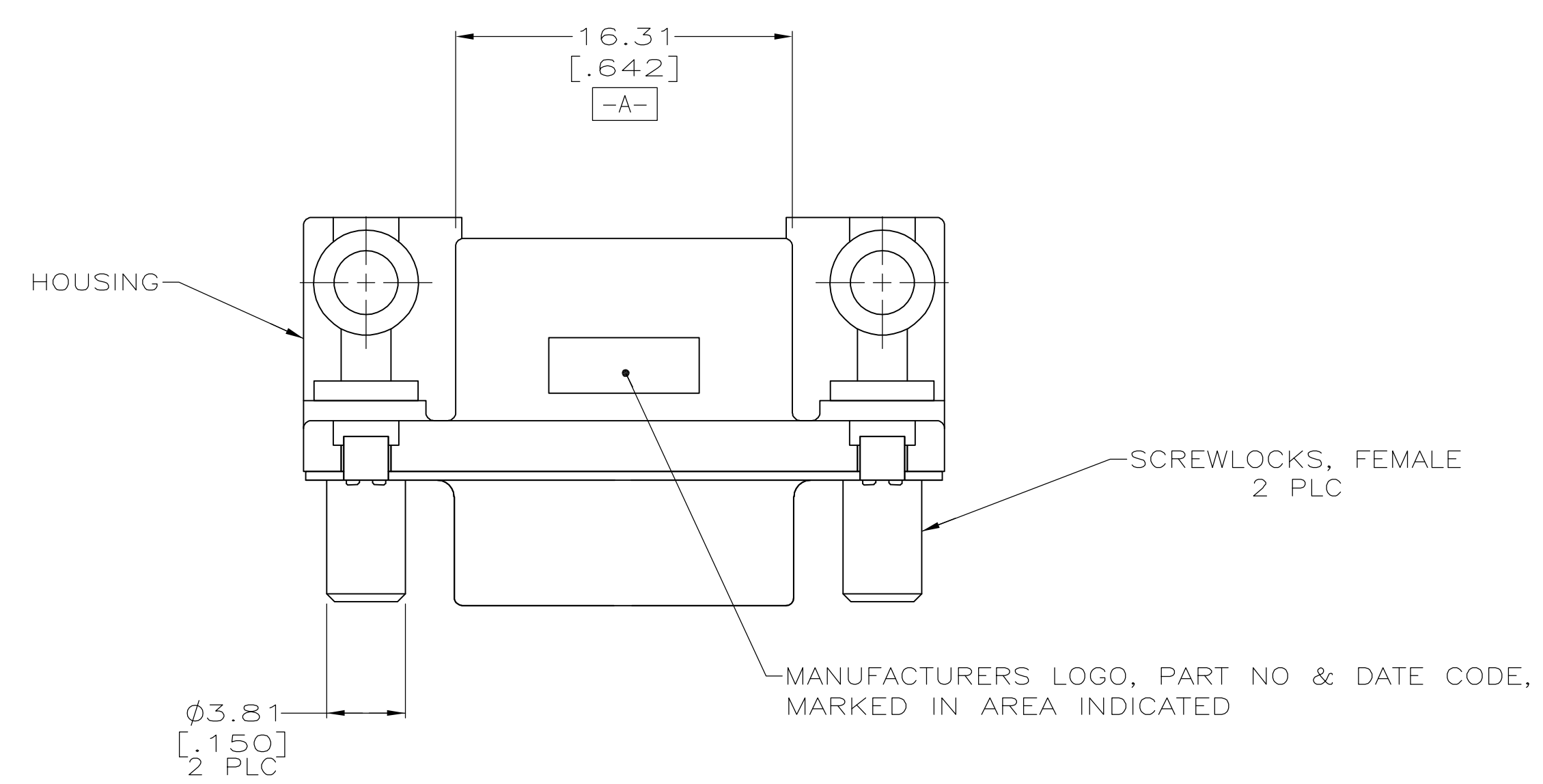

- △ HOUSING & FACE COVER: NYLON, THERMOPLASTIC, UL 94V0 RATED, BLACK; SHELL: CARBON STEEL
- SOCKET CONTACTS: PHOSPHOR BRONZE; EYELETS: BRASS;
- SCREWLOCKS: ZINC.
- △ SOCKET CONTACTS: GOLD PLATED FOR A LENGTH OF 1.27 [.050] MIN FROM MATING END, 0.76µm [.000030] MIN GOLD IN MATED AREA, 2.54µm [.000100] MIN TIN FOR A LENGTH OF 3.56 [.140] MIN FROM OPPOSITE END, BOTH OVER 1.27µm [.000050] MIN NICKEL.
- EYELETS: 2.54µm [.000100] MIN TIN OVER COPPER FLASH.
- SHELL: 2.54µm [.000100] MIN TIN OVER 1.27µm [.000050] MIN COPPER.
- SCREWLOCKS: CLEAR CHROMATE.
- △ DATUMS AND BASIC DIMENSIONS ESTABLISHED BY CUSTOMER.
- △ POSITION TOLERANCE APPLIES AT CONTACT TIP.
- 5. COMPATIBLE WITH SOLDERING APPLICATIONS TO A MAXIMUM OF 225°C FOR A MAXIMUM DURATION OF 90 SECONDS. TEMPERATURE TO BE MEASURED ON CONNECTOR SURFACE.

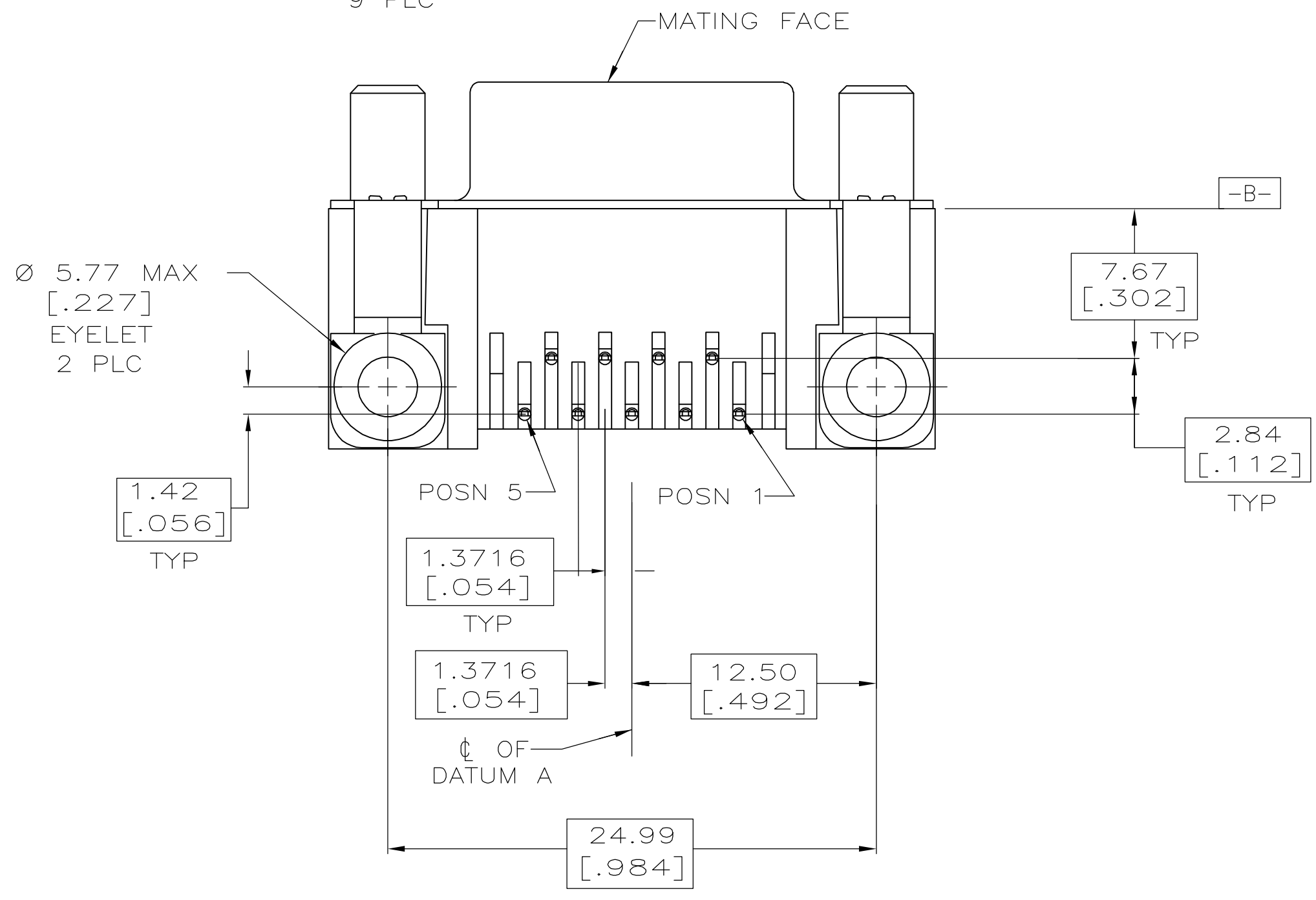
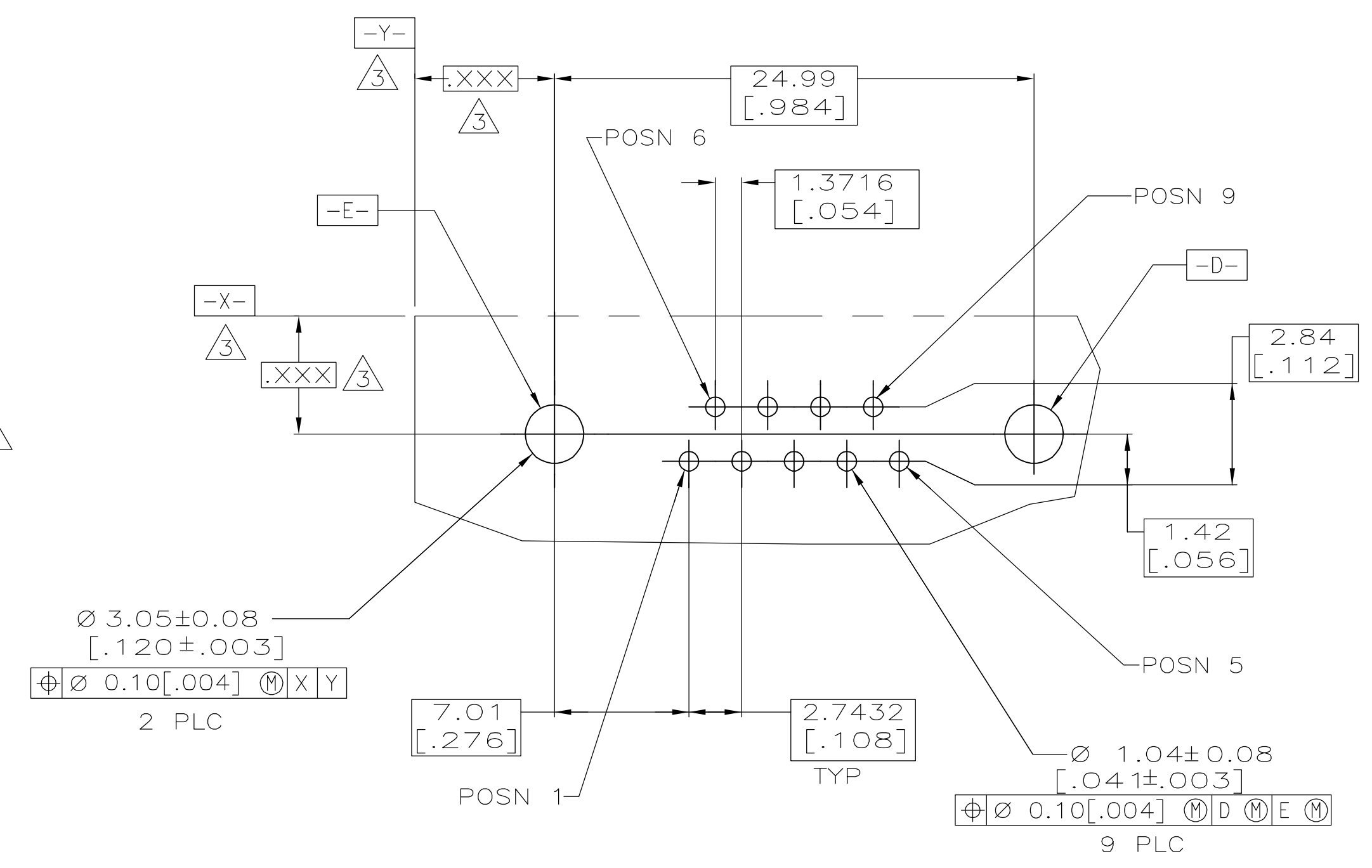
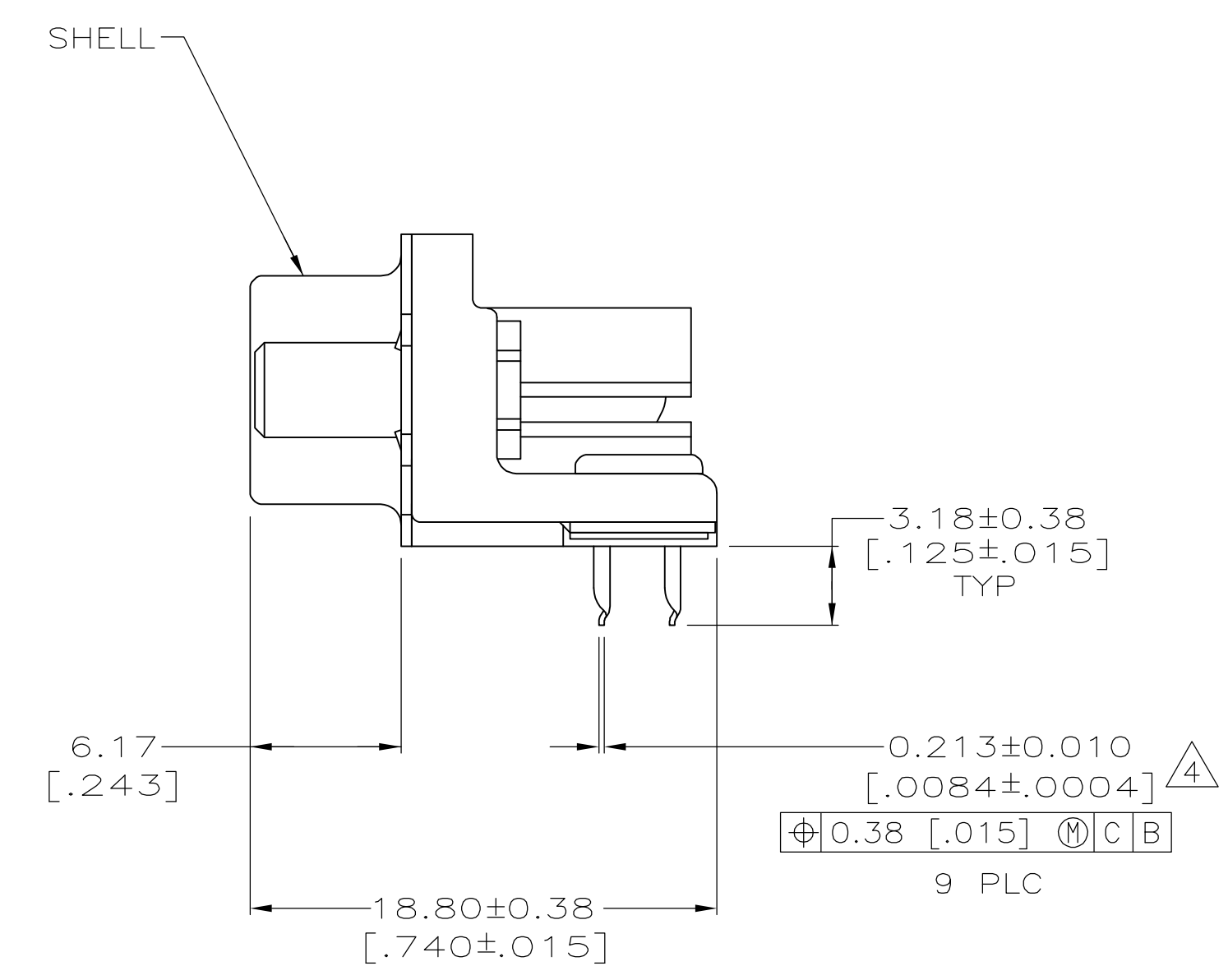
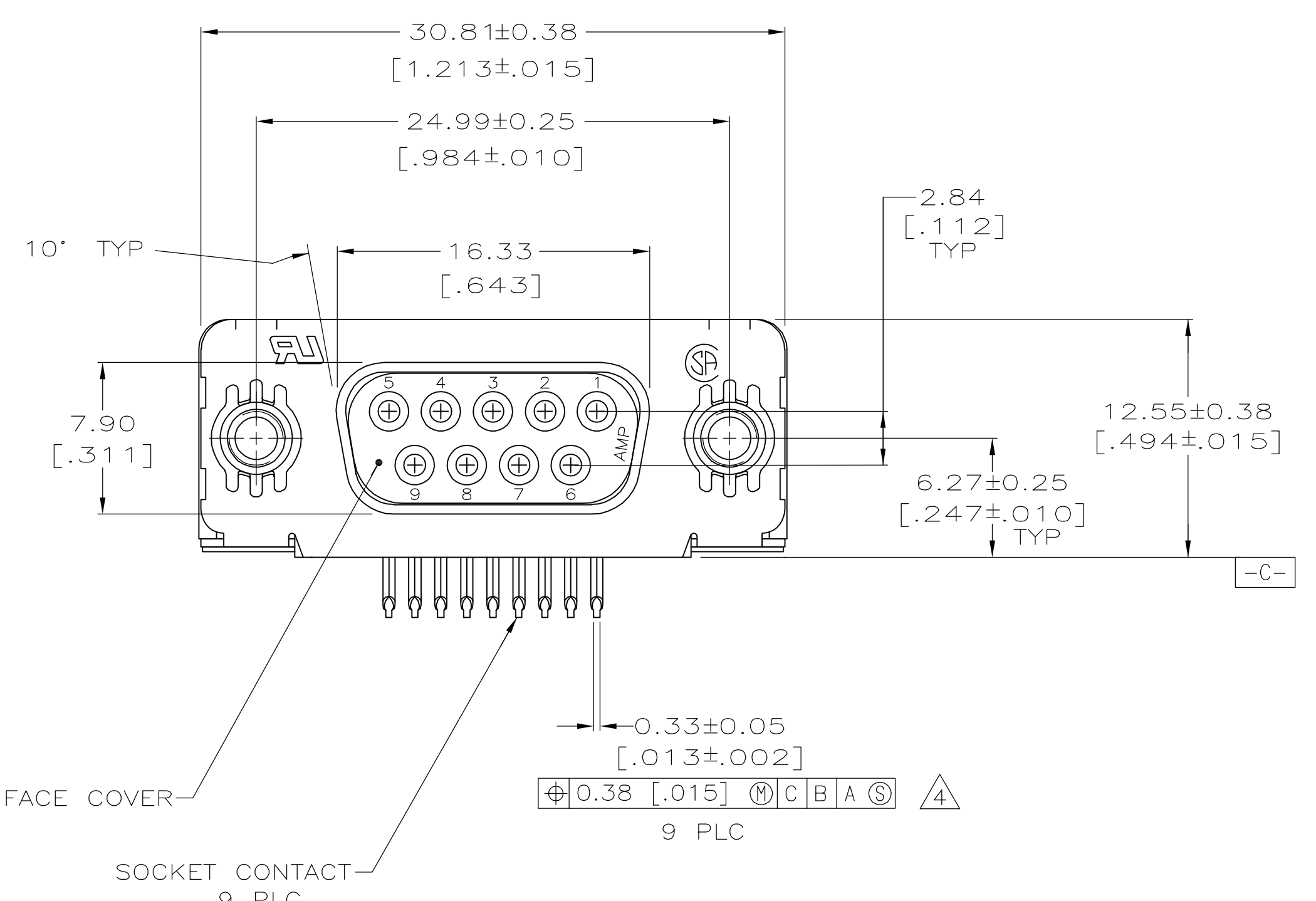

**COPYRIGHT 2005
 TYCO ELECTRONICS CORP
 ALL RIGHTS RESERVED**

THIS DRAWING IS A CONTROLLED DOCUMENT.		DIN J. ALCORTA - DOCK5 04-14-05	Tyco Electronics Corporation Harrisburg, PA 17105-3608
DIMENSIONS: mm [INCHES]		CHK S. BOLASH 04-14-05	
TOLERANCES UNLESS OTHERWISE SPECIFIED:		APVD M. WALMSLEY 04-14-05	NAME RCPT ASSEMBLY, SIZE 1, 318 SERIES, WITH FRONT METAL SHELL, HIGH TEMPERATURE, AMPLITE HD-20
0 PLC ± -	1 PLC ± -	PRODUCT SPEC 108-40025	APPLICATION SPEC 114-40010
2 PLC ± 0.13 [.005]	3 PLC ± -	SIZE A1	CAGE CODE DRAWING NO 00779
4 PLC ± -	ANGLES ± ± °	WEIGHT -	RESTRICTED TO 5788803
MATERIAL 1	FINISH 2	CUSTOMER DRAWING SCALE 4:1 SHEET 1 OF 1 REV 0	

5788803-1
 PART NO

单击下面可查看定价，库存，交付和生命周期等信息

[>>TE Connectivity\(泰科\)](#)

[>>点击查看相关商品](#)