

4

3

2

1

© 2020 TE Connectivity. All Rights Reserved.

B1 MOLD VARIANT 2 : PART MARKINGS

MATED WITH
PASSEND ZU:
967402/1718230PROJEKT NR:
A97-52144

REVISIONS

P	LTR	DESCRIPTION	DATE	DWN	APVD
A		NEW DRAWING	03MAY2000	J.Goets	Hass
A1		NEW DASH-NO. (-2) ADDED	01SEP2000	JG	Hass
B		REVISED PER PCN E-13-005564	22APR2013	KH	JG
B1		REVISED PER PCN E-20-010191	17JUL2020	MK	JG

WAS/war 97-52144-001

ASSEMBLY WITH PIN HOUSING IN CUT-OFF:
Zusammenbau mit Stiftgehäuse
im Befestigungsausschnitt:

1394277-1 WITH RING
mit Ring

SECTION A-A

1394277-2 WITHOUT RING
ohne RingB1 NOTES
Bemerkungen1 TE-PART NUMBER
TE-Part Nummer2 TE-LOGO or AMP-LOGO
TE-Logo or AMP-Logo3 MATERIAL MARKING
Werkstoffkennzeichnung4 REVISION OF THE MOULD
Werkzeugaenderungsindex5 PRODUCTION DATE
Produktionsdatum6 CAVITY MARKING
Nestmarkierung7 INJECTOR MARKING
Injektormarkierung8 SUITABLE FOR:
Passend zu Stiftgehäusen:2-4POS. PIN HOUSING TE-NO. 967402;
5-7POS. PIN HOUSING TE-NO. 1718230Passend zu:
2-4pol. stiftgehäuse TE-Nr. 967402;
5-7pol. stiftgehäuse TE-Nr. 17182309 PACKAGING: LOOSE PIECE IN CARDBOARD BOX
Verpackung: Schuetztgut im Versandkarton

TE ORDER-NO. TE Bestell-Nr.	REV.	POS.	QTY Stueck	MATERIAL	SURFACE Oberflaeche COLOUR Farbe	DESCRIPTION SINGLE PARTS Beschreibung Einzelteile	ITEM NO Itd. Nr.	MATERIAL SEE TABLE siehe Tabelle	FINISH SEE TABLE siehe Tabelle	WEIGHT 7.82/8.42g	SCALE 2:1	SHEET 1 OF 2	REV B1		
1394277-2	B	3	1	PP/EPDM	BLACK schwarz	SEALING Dichtung	2	THIS DRAWING IS A CONTROLLED DOCUMENT. DIESE ZEICHNUNG IST EIN KONTROLLIERTES DOKUMENT.	DWN J.Granzow 06APR2000		NAME COVER FOR 4POS. AND 7POS. PIN HOUSING Schutzkappe	SIZE A2	CAGE CODE 00779	DRAWING NO C-1394277	RESTRICTED TO
		1	1	PA66-GF30	BLACK schwarz	COUPLING RING Kupplungsring		DIMENSIONS: MASSE/WEITEN: mm	TOLERANCES UNLESS OTHERWISE SPECIFIED: ALLGEMEINTOLERANZEN Acc. to ISO 8015						
1394277-1	B	2	1	PP/EPDM	BLACK schwarz	SEALING WITH RING Dichtung mit Ring	1		APVD Ch. Eberwein 22APR2013	PRODUCT SPEC 108-18621/18622	APPLICATION SPEC 114-18255	SCALE 2:1	SHEET 1 OF 2	REV B1	
		1	1	PA66-GF30	BLACK schwarz	COUPLING RING Kupplungsring			APVD Ch. Eberwein 22APR2013	PRODUCT SPEC 108-18621/18622	APPLICATION SPEC 114-18255	SCALE 2:1	SHEET 1 OF 2	REV B1	

1471-9 (3/13)

Downloaded From Onevac.com

P	LTR	DESCRIPTION	DATE	DWN	APVD
-		SEE SHEET 1	-	-	-

B1 MOLD VARIANT 1 : PART MARKINGS

1394277-1 WITH RING
mit Ring

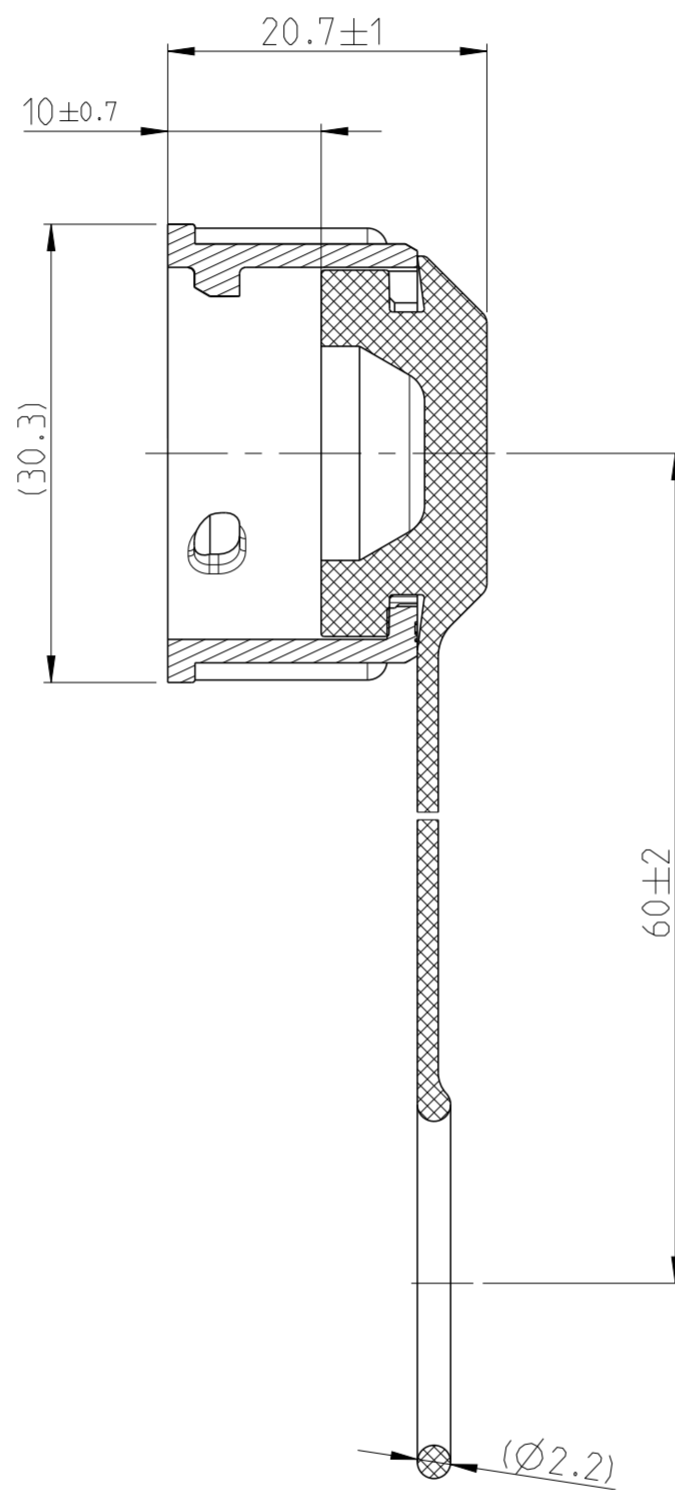
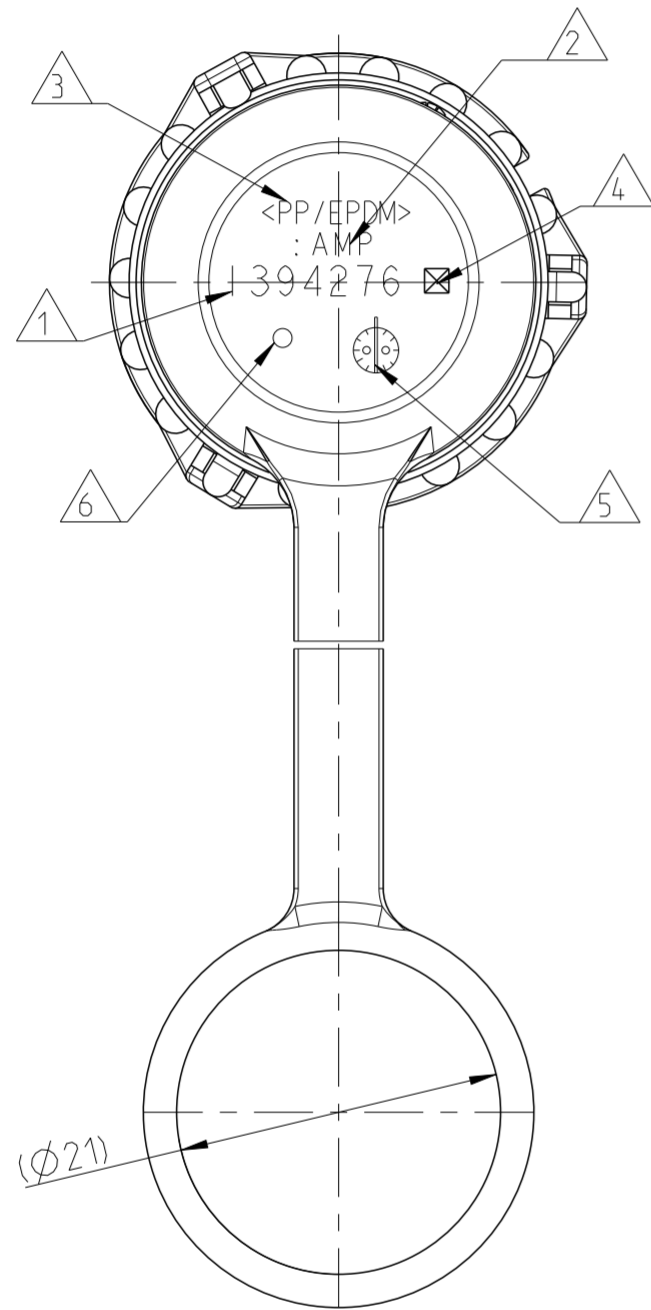

SECTION A-A

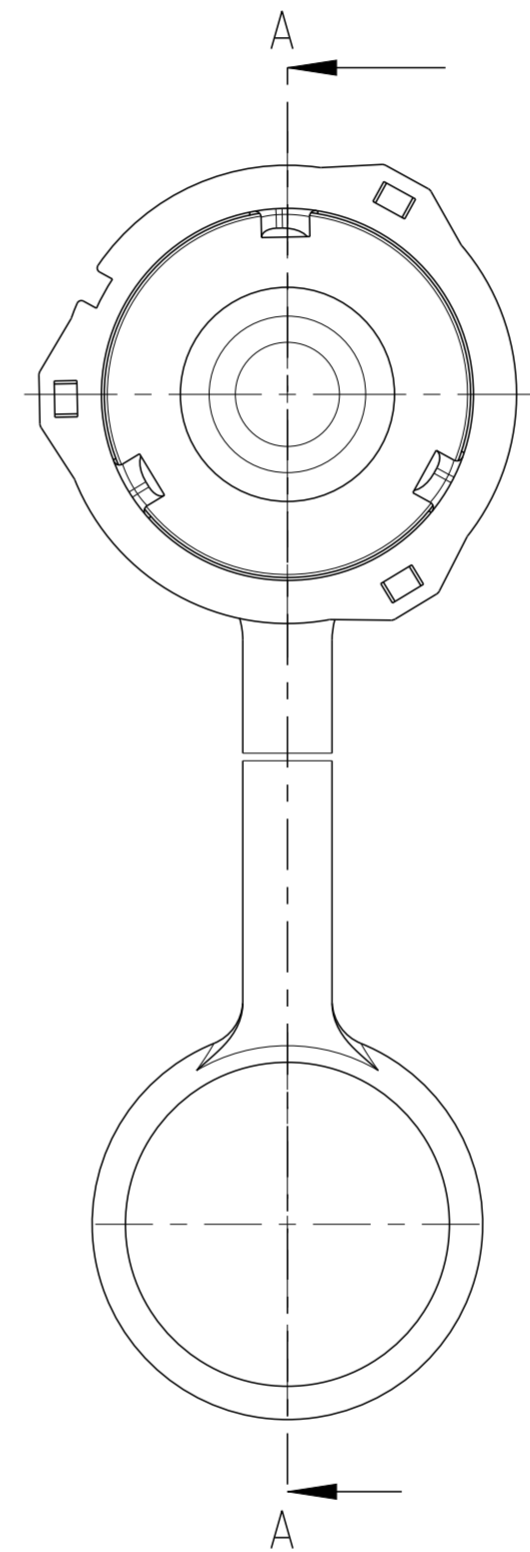

1394277-2 WITHOUT RING
ohne Ring

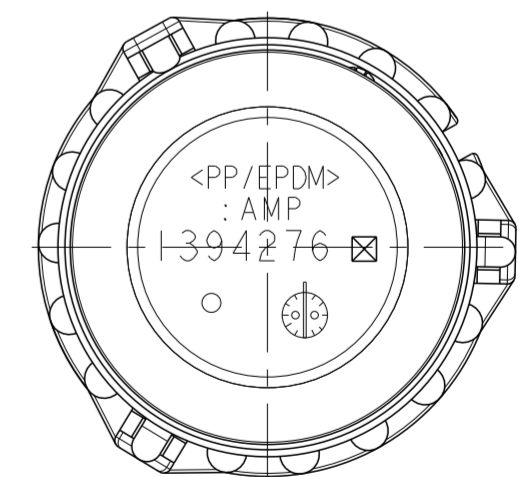

THIS DRAWING IS A CONTROLLED DOCUMENT. DIESE ZEICHNUNG IST EIN KONTROLLIERTES DOKUMENT.		DWN J.Granzow 06APR2000		
		CHK J.Granzow 22APR2013		
DIMENSIONS: MASSENWEITEN: (mm)		APVD Ch. Eberwein 22APR2013	NAME COVER FOR 4POS. AND 7POS.PIN HOUSING Schutzkappe	
TOLERANCES UNLESS OTHERWISE SPECIFIED: ALLGEMEINTOLERANZEN Acc.to ISO 8015		PRODUCT SPEC 108-18621/18622	SIZE A2	
0-PLC ±0.5mm 1-PLC ± 2-PLC ± 3-PLC ± 4-PLC ±		APPLICATION SPEC 114-18255	CAGE CODE 00779	
MATERIAL SEE TABLE siehe Tabelle		WEIGHT 7.82/8.42g	DRAWING NO C-1394277	
FINISH SEE TABLE siehe Tabelle		CUSTOMER DRAWING	RESTRICTED TO	
		SCALE 2:1	SHEET 2 OF 2	
			REV B1	

单击下面可查看定价，库存，交付和生命周期等信息

[>>TE Connectivity\(泰科\)](#)