

LOC	DIST	REVISIONS			
P	LTN	DESCRIPTION	DATE	DWN	APVD
GP	00	A	REVISED PER ECO-12-018933	31OCT12	KH MH
-	-	-	-	-	-
-	-	-	-	-	-

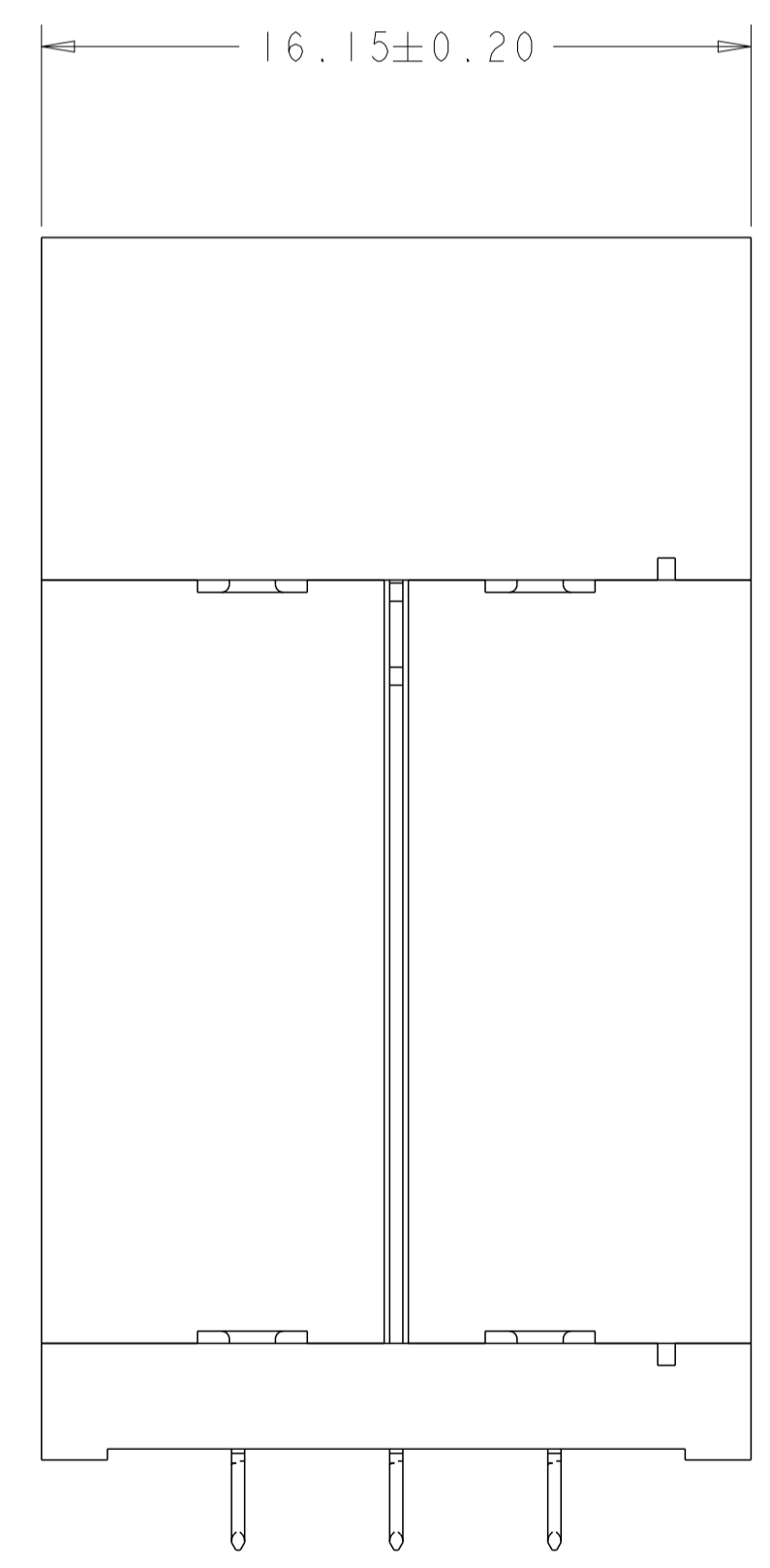
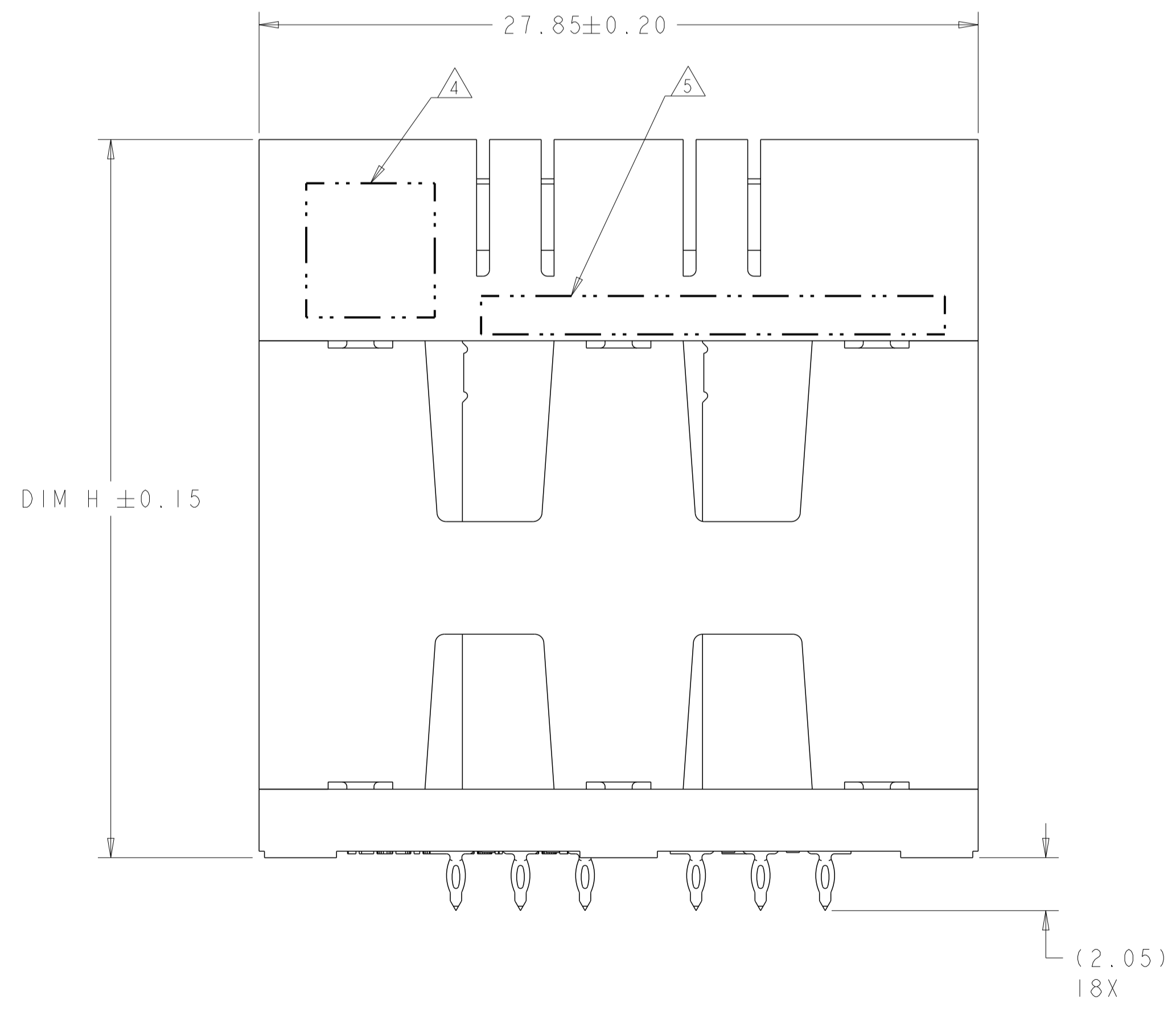
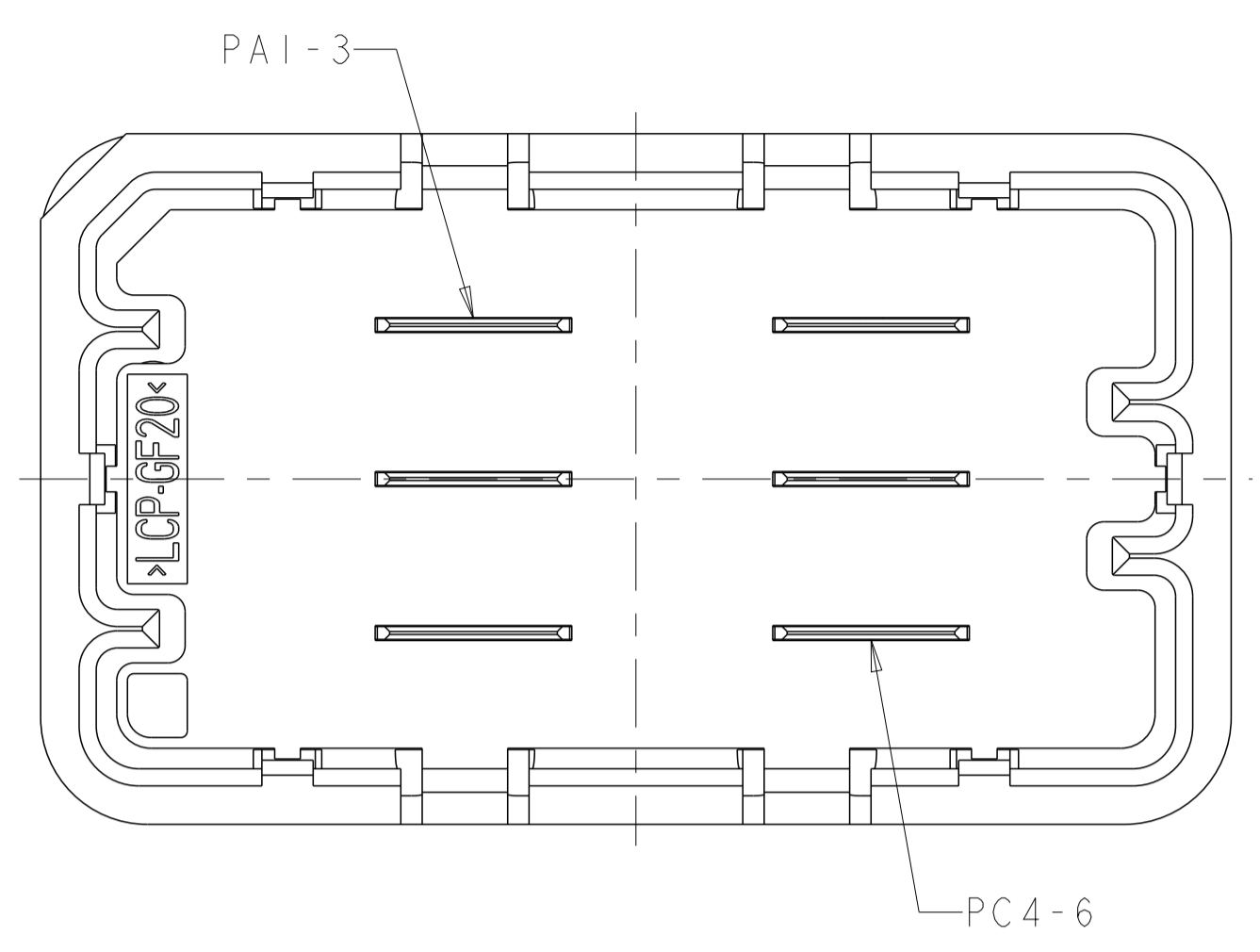

- △ MATERIAL:
 BASE HOUSING, UPPER HOUSING, ORGANIZER,
 AND SPACER: THERMOPLASTIC, FLAMMABILITY
 RATING UL94 V-0
 CONTACT: COPPER ALLOY
- 2. CONFORMS TO THE REQUIREMENTS OF TE PRODUCT
 SPECIFICATION, 108-2375; BASED ON TELCORDIA
 GR-1217-CORE FOR SYSTEM QUALITY LEVEL III,
 APPLICATIONS IN CONTROLLED ENVIRONMENTS
 (CENTRAL OFFICE).
 SEE TE PRODUCT SPECIFICATION 108-2375 FOR
 TEST SEQUENCES.
- △ 3. SPECIFIED POSITIONAL TOLERANCE DEFINES HOLE TO
 HOLE LOCATION WITHIN HOLE PATTERN. POSITIONAL
 TOLERANCE OF HOLE PATTERN TO FIDUCIAL MARKS
 OR PCB DATUMS SHALL BE DEFINED BY CUSTOMER.
- △ 4. AREA RESERVED FOR TE CONNECTIVITY LOGO.
- △ 5. AREA RESERVED FOR PART NUMBER (X-XXXXXXX-X) AND
 DATE CODE (YYWW).
- △ 6. USE CENTER LINES INDICATED ON PCB HOLE PATTERN
 TO ESTABLISH ALIGNMENT BETWEEN HEADER AND
 RECEPTACLE BOARDS.
- △ PLATED THROUGH HOLE REQUIREMENTS:
 HOLE SIZE PRIOR TO PLATING = $\varnothing 0.700 \pm 0.025$
 COPPER PLATING THICKNESS = 0.038 ± 0.013
 CALCULATED FINISHED HOLE SIZE = $\varnothing 0.624 \pm 0.051$
 THESE DIMENSIONS APPLY TO THE TOP 1.50mm OF
 THE PCB THICKNESS FROM THE CONNECTOR MOUNTING
 SIDE.
- △ CONTACT SALES FOR AVAILABILITY OF THIS STACK
 HEIGHT.

SIZE 1 HALF-WIDE *
6 POWER CONTACTS

* SIZE 2 AND SIZE 3 ARE ALSO AVAILABLE

THIS DRAWING IS A CONTROLLED DOCUMENT.		DWN HAMNER 02NOV2010	TE Connectivity
DIMENSIONS:		CHK D. TROUT 03NOV2010	
mm	TOLERANCES UNLESS OTHERWISE SPECIFIED:	APVD J. FEEDER 03NOV2010	NAME HEADER ASSEMBLY, HALF-WIDE, 6P, STRADA MESA MEZZANINE CONNECTOR
0 PLC ± 2 PLC ±0.13 3 PLC ±0.013 4 PLC ± ANGLES ±1	FINISH ±	PRODUCT SPEC 108-2375 APPLICATION SPEC 114-13249 WEIGHT - Customer Drawing	SIZE CAGE CODE DRAWING NO A100779C=2149520 RESTRICTED TO
MATERIAL	△	SCALE 6:1	SHEET 1 OF 4 REV A

LOC	DIST	REVISIONS			
P	LYR	DESCRIPTION	DATE	OWN	APVD
GP	00	SEE SHEET 1	-	-	-

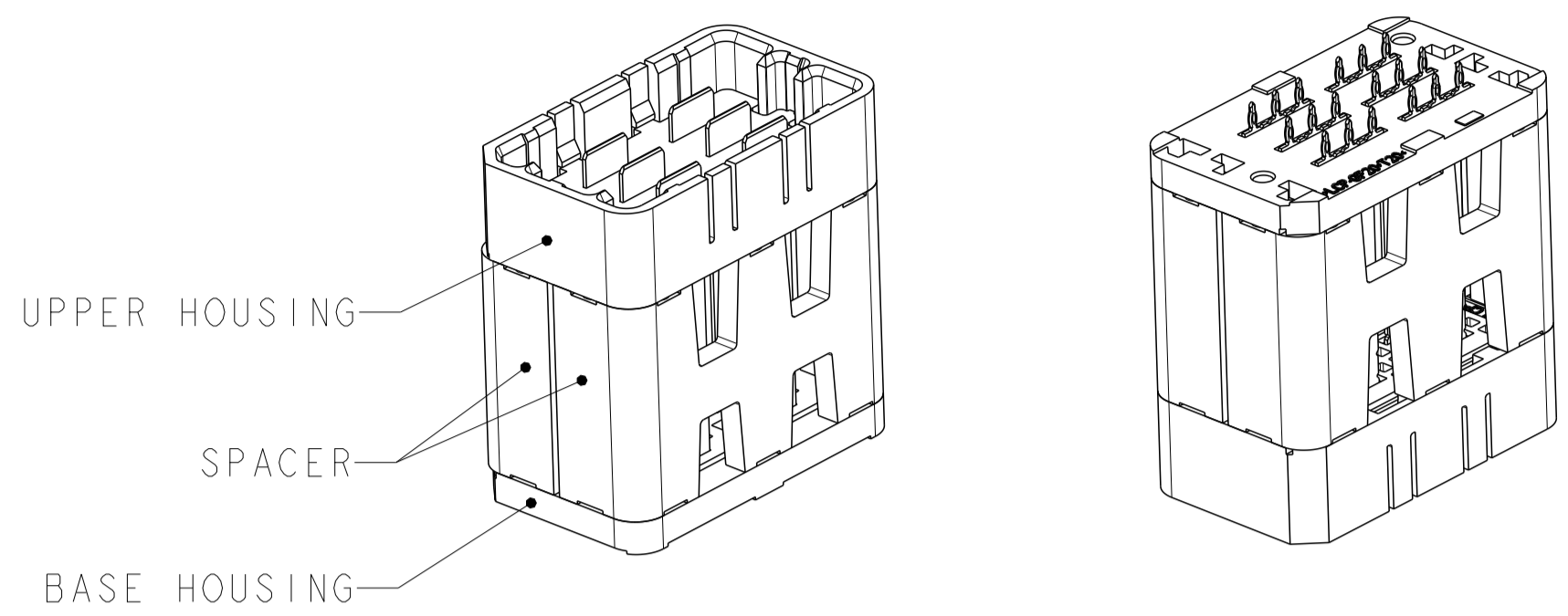

ISOMETRIC VIEW
 TYPICAL CONFIGURATION FOR 14mm THRU 42mm
 28mm SHOWN
 SCALE 2:1

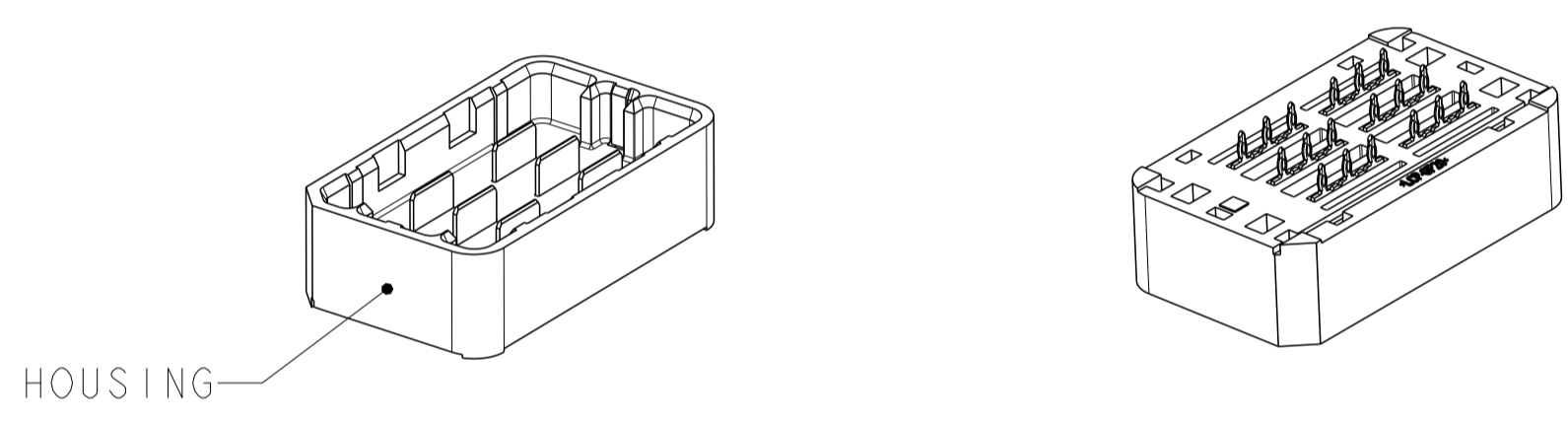

ISOMETRIC VIEWS
 TYPICAL CONFIGURATION FOR 8mm THRU 13mm
 8mm SHOWN
 SCALE 2:1

TOOLED	DIM H	STACK HEIGHT	CONTACT TAIL PLATING	PART NUMBER
△	41.8	42mm	MATTE Sn	9-2149520-2
△	40.8	41mm	MATTE Sn	9-2149520-1
YES	39.8	40mm	MATTE Sn	9-2149520-0
△	38.8	39mm	MATTE Sn	8-2149520-9
△	37.8	38mm	MATTE Sn	8-2149520-8
△	36.8	37mm	MATTE Sn	8-2149520-7
△	35.8	36mm	MATTE Sn	8-2149520-6
△	34.8	35mm	MATTE Sn	8-2149520-5
△	33.8	34mm	MATTE Sn	8-2149520-4
△	32.8	33mm	MATTE Sn	8-2149520-3
△	31.8	32mm	MATTE Sn	8-2149520-2
△	30.8	31mm	MATTE Sn	8-2149520-1
△	29.8	30mm	MATTE Sn	8-2149520-0
△	28.8	29mm	MATTE Sn	7-2149520-9
△	27.8	28mm	MATTE Sn	7-2149520-8
△	26.8	27mm	MATTE Sn	7-2149520-7
△	25.8	26mm	MATTE Sn	7-2149520-6
YES	24.8	25mm	MATTE Sn	7-2149520-5
△	23.8	24mm	MATTE Sn	7-2149520-4
△	22.8	23mm	MATTE Sn	7-2149520-3
YES	21.8	22mm	MATTE Sn	7-2149520-2
△	20.8	21mm	MATTE Sn	7-2149520-1
△	19.8	20mm	MATTE Sn	7-2149520-0
△	18.8	19mm	MATTE Sn	6-2149520-9
△	17.8	18mm	MATTE Sn	6-2149520-8
△	16.8	17mm	MATTE Sn	6-2149520-7
△	15.8	16mm	MATTE Sn	6-2149520-6
△	14.8	15mm	MATTE Sn	6-2149520-5
△	13.8	14mm	MATTE Sn	6-2149520-4
△	12.8	13mm	MATTE Sn	6-2149520-3
△	11.8	12mm	MATTE Sn	6-2149520-2
△	10.8	11mm	MATTE Sn	6-2149520-1
△	9.8	10mm	MATTE Sn	6-2149520-0
△	8.8	9mm	MATTE Sn	5-2149520-9
△	7.8	8mm	MATTE Sn	5-2149520-8

TOOLED	DIM H	STACK HEIGHT	CONTACT TAIL PLATING	PART NUMBER
△	41.8	42mm	Sn/Pb	4-2149520-2
△	40.8	41mm	Sn/Pb	4-2149520-1
YES	39.8	40mm	Sn/Pb	4-2149520-0
△	38.8	39mm	Sn/Pb	3-2149520-9
△	37.8	38mm	Sn/Pb	3-2149520-8
△	36.8	37mm	Sn/Pb	3-2149520-7
△	35.8	36mm	Sn/Pb	3-2149520-6
△	34.8	35mm	Sn/Pb	3-2149520-5
△	33.8	34mm	Sn/Pb	3-2149520-4
△	32.8	33mm	Sn/Pb	3-2149520-3
△	31.8	32mm	Sn/Pb	3-2149520-2
△	30.8	31mm	Sn/Pb	3-2149520-1
△	29.8	30mm	Sn/Pb	3-2149520-0
△	28.8	29mm	Sn/Pb	2-2149520-9
△	27.8	28mm	Sn/Pb	2-2149520-8
△	26.8	27mm	Sn/Pb	2-2149520-7
△	25.8	26mm	Sn/Pb	2-2149520-6
YES	24.8	25mm	Sn/Pb	2-2149520-5
△	23.8	24mm	Sn/Pb	2-2149520-4
△	22.8	23mm	Sn/Pb	2-2149520-3
YES	21.8	22mm	Sn/Pb	2-2149520-2
△	20.8	21mm	Sn/Pb	2-2149520-1
△	19.8	20mm	Sn/Pb	2-2149520-0
△	18.8	19mm	Sn/Pb	1-2149520-9
△	17.8	18mm	Sn/Pb	1-2149520-8
△	16.8	17mm	Sn/Pb	1-2149520-7
△	15.8	16mm	Sn/Pb	1-2149520-6
△	14.8	15mm	Sn/Pb	1-2149520-5
△	13.8	14mm	Sn/Pb	1-2149520-4
△	12.8	13mm	Sn/Pb	1-2149520-3
△	11.8	12mm	Sn/Pb	1-2149520-2
△	10.8	11mm	Sn/Pb	1-2149520-1
△	9.8	10mm	Sn/Pb	1-2149520-0
△	8.8	9mm	Sn/Pb	2149520-9
△	7.8	8mm	Sn/Pb	2149520-8

THIS DRAWING IS A CONTROLLED DOCUMENT. DWN HAMNER 02NOV2010
 CHK D. TROUT 03NOV2010
 APVD J. FEDDER 03NOV2010

STE TE Connectivity

NAME: HEADER ASSEMBLY, HALF-WIDE, 6P, STRADA MESA MEZZANINE CONNECTOR

PRODUCT SPEC: 108-2375
 APPLICATION SPEC: 114-13249

SIZE: A1 CAGE CODE: 2149520 DRAWING NO: 100779

RESTRICTED TO: Customer Drawing SCALE: 6:1 SHEET 2 OF 4 REV A

THIS DRAWING IS UNPUBLISHED. RELEASED FOR PUBLICATION 20
 © COPYRIGHT 20 BY - ALL RIGHTS RESERVED.

LOC	DIST	REVISIONS					
		P	LTN	DESCRIPTION	DATE	DWN	APVD
GP	00	-	-	SEE SHEET 1	-	-	-

AI CORNER INDICATORS

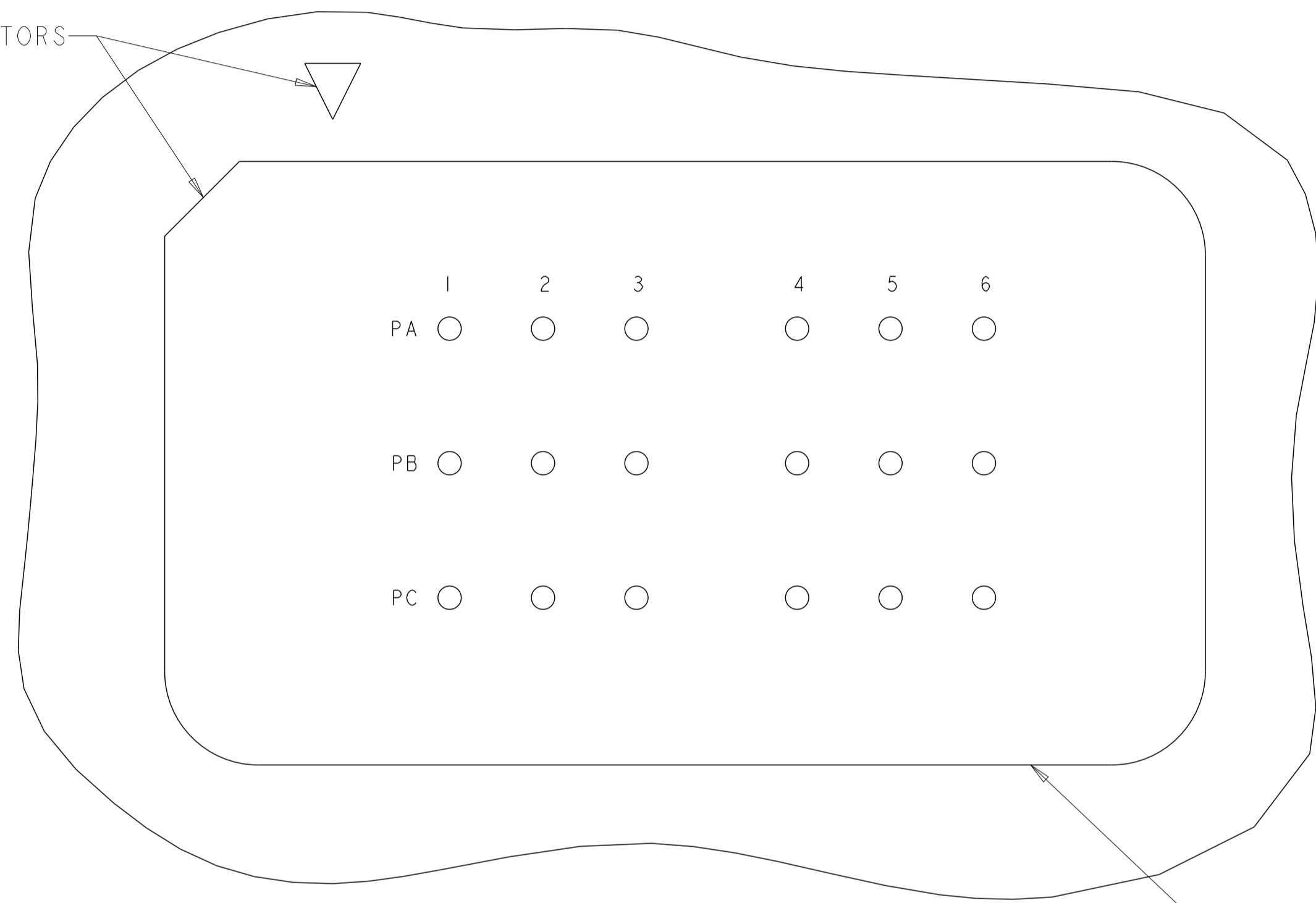

MATED CONNECTOR OUTLINE
 SEE SHEET 4 FOR LOCATION TO HOLES

PCB LAYOUT AND PIN IDENTIFICATION
 SHOWN FROM CONNECTOR SIDE
 SCALE 8:1

THIS DRAWING IS A CONTROLLED DOCUMENT.		DWN HAMNER 02NOV2010	 TE Connectivity
		CHK D. TROUT 03NOV2010	
DIMENSIONS:		APVD J. FEDDER 03NOV2010	NAME
TOLERANCES UNLESS OTHERWISE SPECIFIED:		PRODUCT SPEC	HEADER ASSEMBLY, HALF-WIDE, 6P,
mm	0 PLC ±	108-2375	STRADA MESA MEZZANINE CONNECTOR
	1 PLC ±	APPLICATION SPEC	SIZE CAGE CODE DRAWING NO RESTRICTED TO
	2 PLC ±0.13	114-13249	A100779C=2149520
	3 PLC ±0.013	WEIGHT	-
	4 PLC ±	Customer Drawing	SCALE 6:1 SHEET 3 OF 4 REV A
	ANGLES ±1		
MATERIAL	FINISH		

LOC		DIST		REVISIONS			
P	LTN	DESCRIPTION	DATE	DMN	APVD		
-	-	SEE SHEET 1	-	-	-		

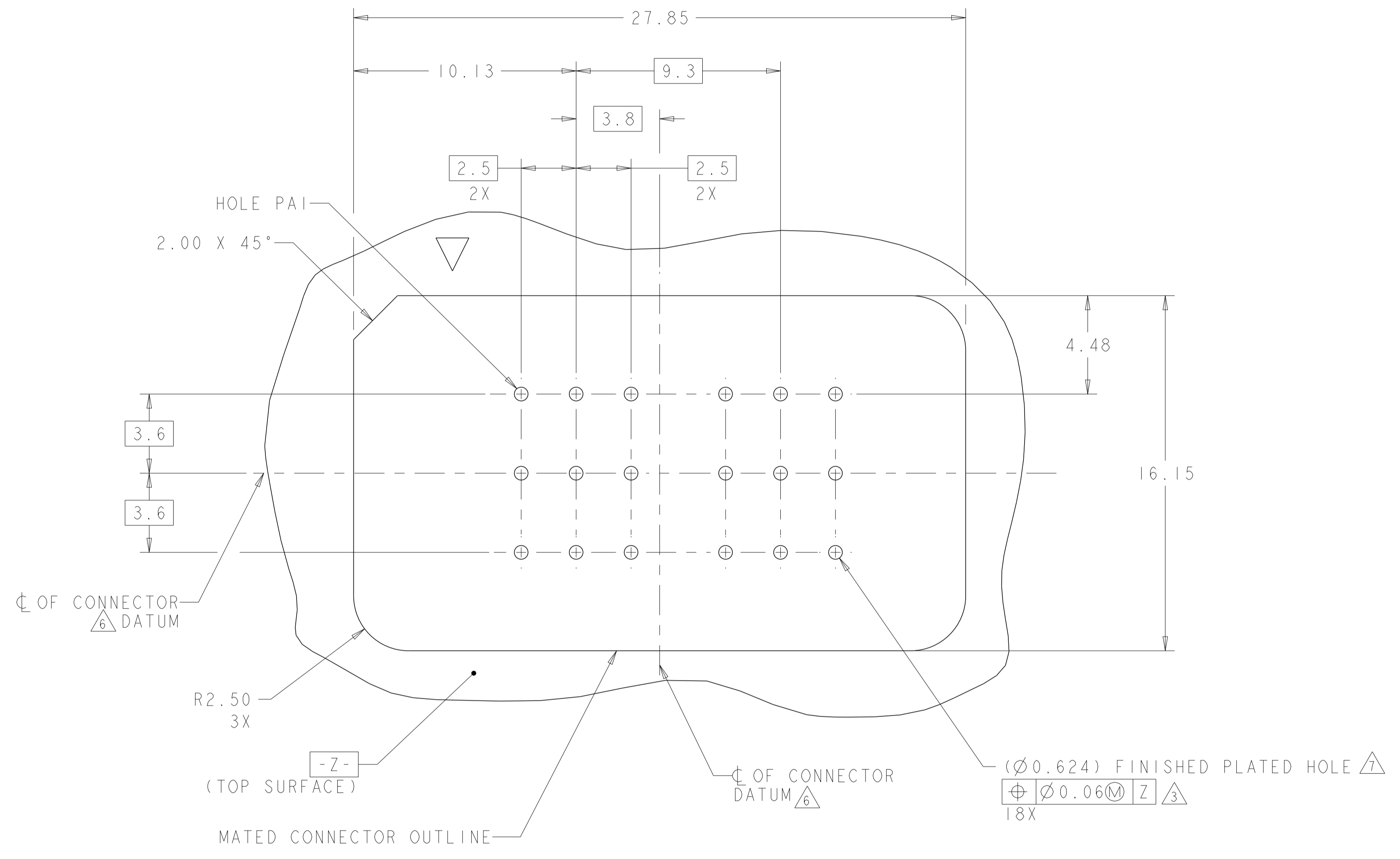

PCB HOLE PATTERN
 SHOWN FROM CONNECTOR SIDE
 SCALE 7:1

THIS DRAWING IS A CONTROLLED DOCUMENT.		DMN HAMNER 02NOV2010	TE Connectivity
DIMENSIONS: mm		CHK D. TROUT 03NOV2010	
TOLERANCES UNLESS OTHERWISE SPECIFIED: 0 PLC ± 1 PLC ± 2 PLC ±0.13 3 PLC ±0.013 4 PLC ± ANGLES ±1 FINISH -		APVD J. FEDDER 03NOV2010	NAME
MATERIAL -		PRODUCT SPEC 108-2375	HEADER ASSEMBLY, HALF-WIDE, 6P, STRADA MESA MEZZANINE CONNECTOR
		APPLICATION SPEC 114-13249	SIZE CAGE CODE DRAWING NO RESTRICTED TO
		WEIGHT -	A 100779 C=2149520
		Customer Drawing	SCALE 6:1 SHEET 4 OF 4 REV A

单击下面可查看定价，库存，交付和生命周期等信息

[>>TE Connectivity\(泰科\)](#)