

THIS DRAWING IS UNPUBLISHED. RELEASED FOR PUBLICATION
 © COPYRIGHT - By - ALL RIGHTS RESERVED.

LOC		DIST		REVISIONS			
P	LTR	DESCRIPTION	DATE	DWN	APVD		
D		REV PER ECO-11-005194	15JUL11	PY	DE		

- 1 TE INFO MARKED PER MIL-STD-130.
- 2 MARKED AS SHOWN IN RED INK.
- 3 THIS END MATES WITH TE PART NO. 859059-1.

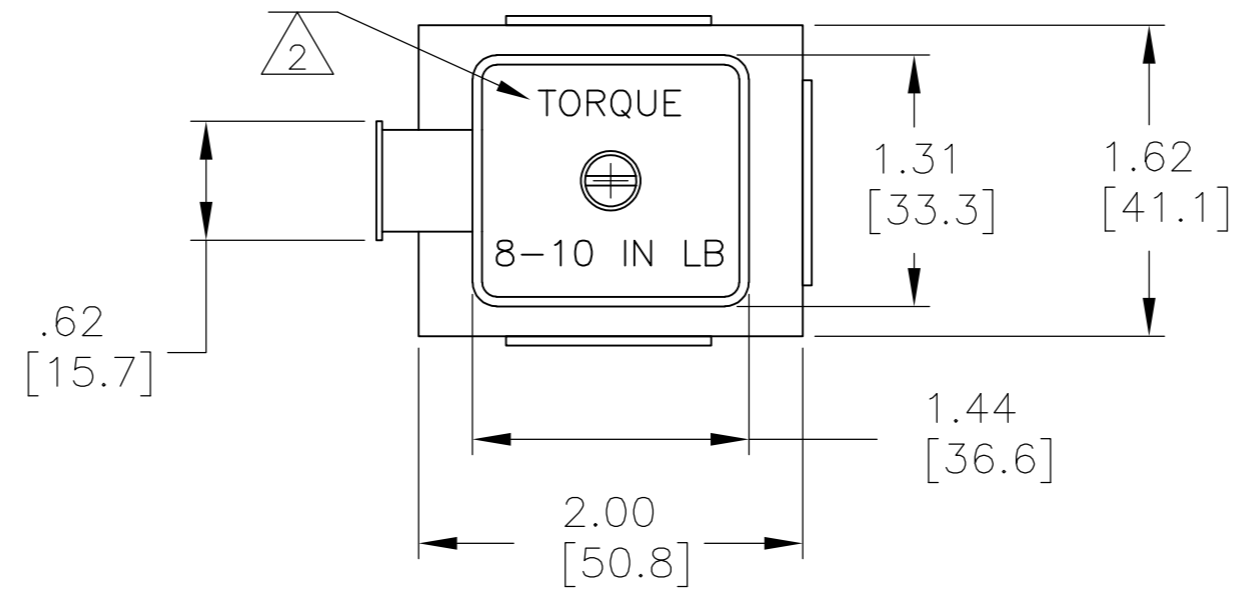
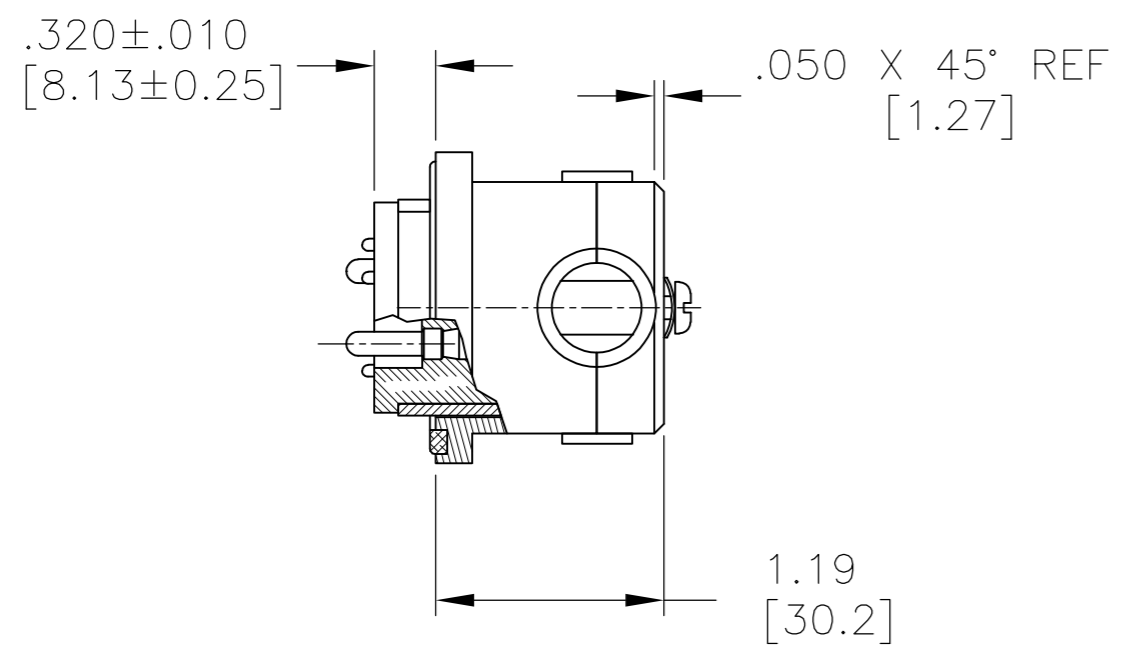
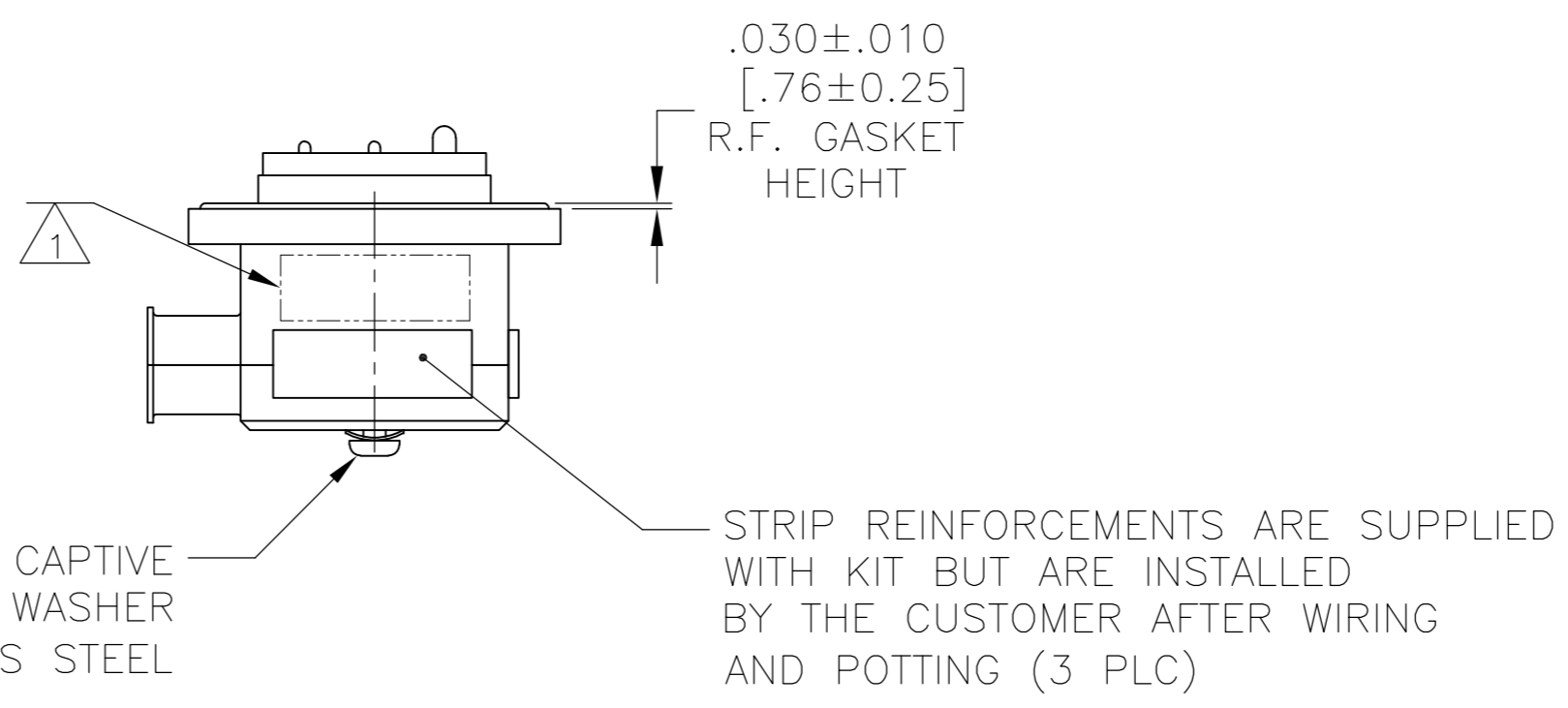
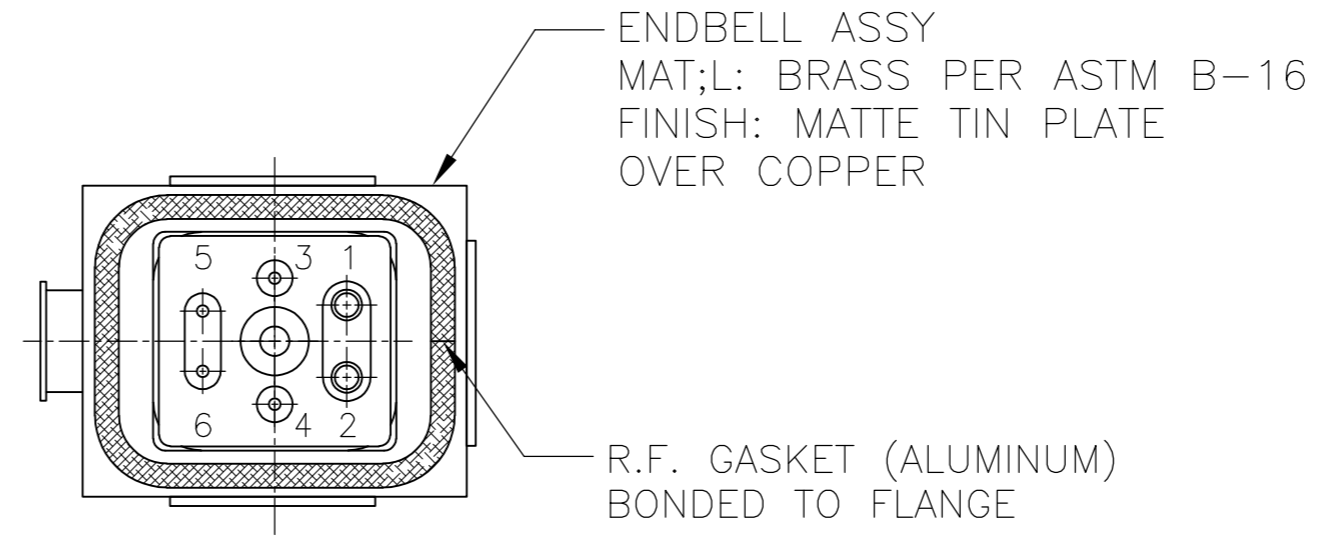

OBSOLETE	ELASTOMER FLOUROSILICONE MLDG. CMPD.	858057-3
	85/15 FLOUROSILICONE/ SILICONE MOLDING COMPOUND	858057-2
OBSOLETE	SILICONE RUBBER MLDG. CMPD.	858057-1
	MOLDED PLUG MATERIAL	PART NO.

DIMENSIONS:		TOLERANCES UNLESS OTHERWISE SPECIFIED:		DWN		C.C.THOMAS		6-4-09	
INCHES		0 PLC	± -	CHK	D.EABY	6-4-09		TE Connectivity	
		1 PLC	± -	APVD	D.EABY	6-4-09		NAME	
		2 PLC	± .03 [0.8]	PRODUCT SPEC	PLUG AND ENDBELL ASSY,LGH				
		3 PLC	± -	APPLICATION SPEC					
		4 PLC	± -	FINISH					
		ANGLES	± -	WEIGHT					
MATERIAL		SEE CALLOUTS		SCALE		A2 00779		C=858057	
SEE CALLOUTS		SEE CALLOUTS		CUSTOMER DRAWING		SCALE 1:1		SHEET 1 of 1	

858057

单击下面可查看定价，库存，交付和生命周期等信息

[>>TE Connectivity\(泰科\)](#)