

- 1 POST TO WITHSTAND 13 NEWTONS (3LBS.) MIN. AXIAL FORCE IN BOTH DIRECTIONS SHOWN WITHOUT DISLODGING.
- 2 TOLERANCES APPLY TO SOLDER SIDE OF BOARD.
- 3 MEASURED AT SURFACE -A-
- 4 PLASTIC FLASH PERMITTED IN THIS AREA.
- 5 PARTS COMPLY WITH AMP SOLDERABILITY SPEC. NO. 109-11-2.
- 6 ONE HOLE MAY BE UNDERSIZED (.065/.060 DIA.) FOR ASSEMBLY RETENTION DURING WAVE SOLDERING.
- 7 MATERIAL: HEADER-THERMOPLASTIC POLYESTER
GLASS-FILLED 94V-0 (NATURAL)
POST-COPPER ALLOY (BRIGHT TIN LEAD FOR CONTACTS 644754-2 THRU 2-644754-4;
MATTE TIN FOR CONTACTS 3-644754-2 THRU 5-644754-4)
- 8 COORDINATE DIMENSION APPLIES FROM CENTER OF ACTUAL FEATURE.
- 9 PLASTIC BURRS CAUSED BY CUT-OFF TOOLING ARE PERMITTED WITHIN THE MAXIMUM TOLERANCE ENVELOPE.
- 10 POST TO BE MEASURED WHEN STRIP IS HELD FLAT.
- 11 POST MUST WITHSTAND TWO 90° BENDS AGAINST EXTRUSION WITHOUT BREAKING.
- 12 DIMENSION SHOULD BE .325-.400 WHEN MATING WITH A MTA 156 CONNECTOR ASSEMBLY OR .325-.345 WHEN MATING WITH A SL-156 CONNECTOR ASSEMBLY.
- 13 PIN BURR OF .005 MAX. VERTICAL AND .003 MAX. HORIZONTAL PERMITTED AT POST TIPS ON BOTH ENDS.
- 14 OBSOLETE PARTS: OBSOLETE CIS STREAMLINING PER D.RENAUD/D.SINISI

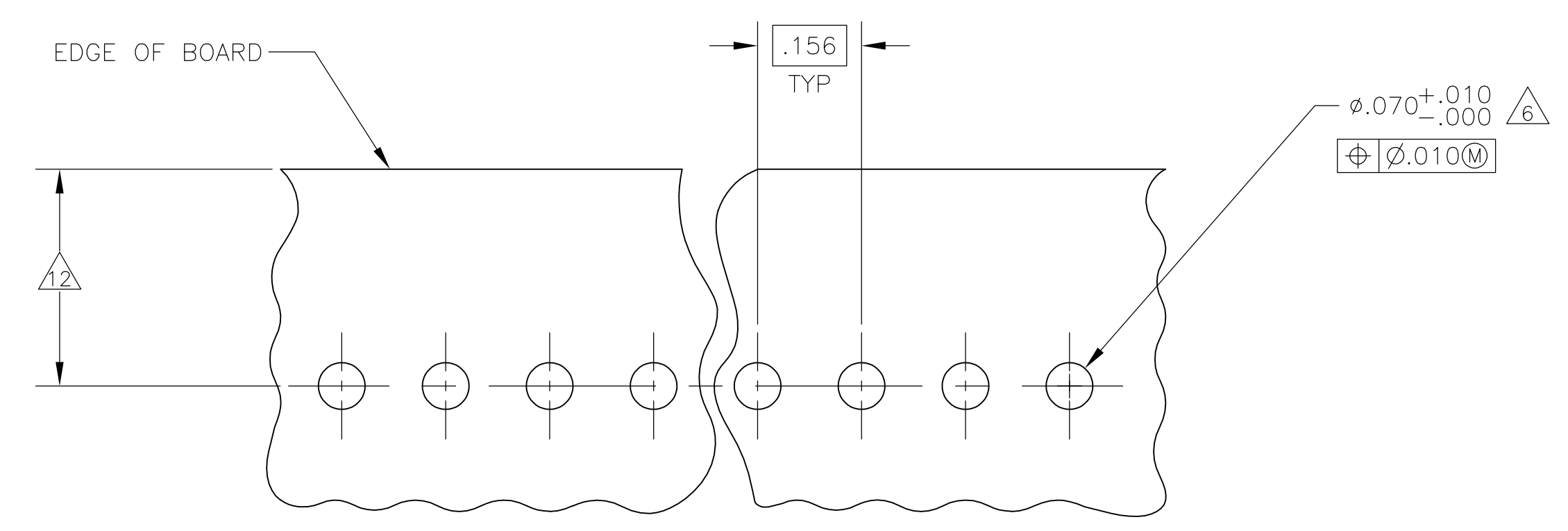
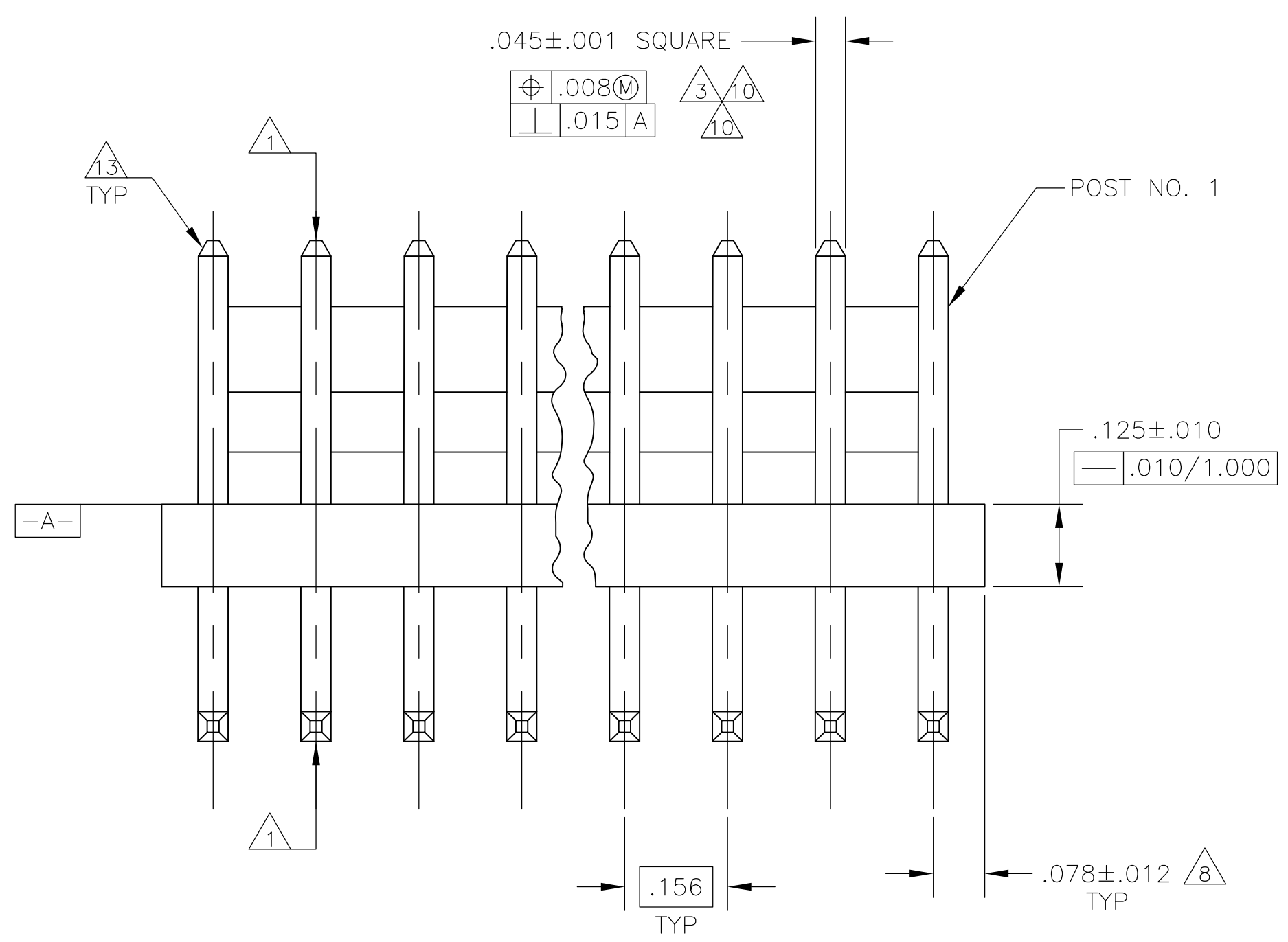
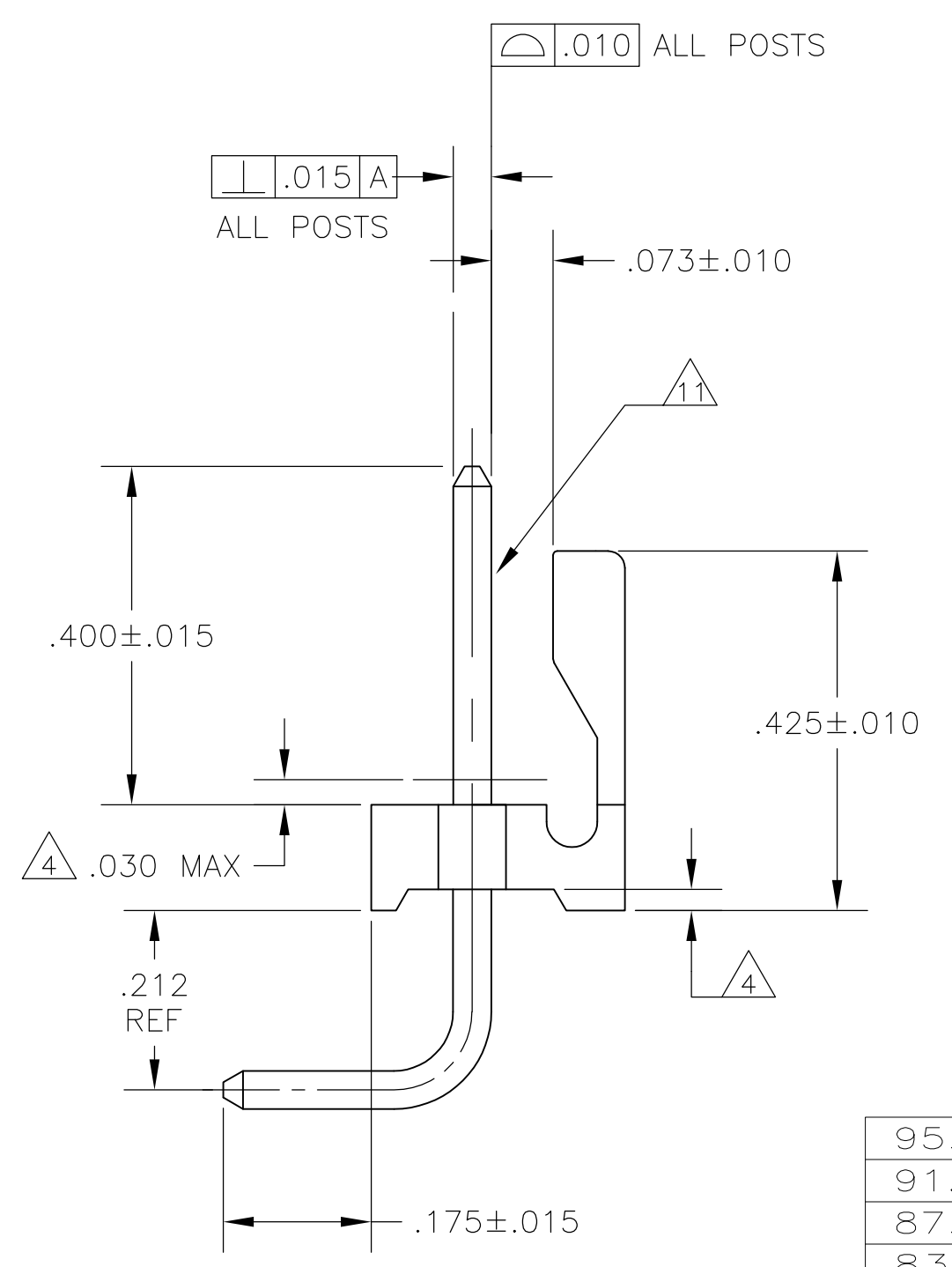
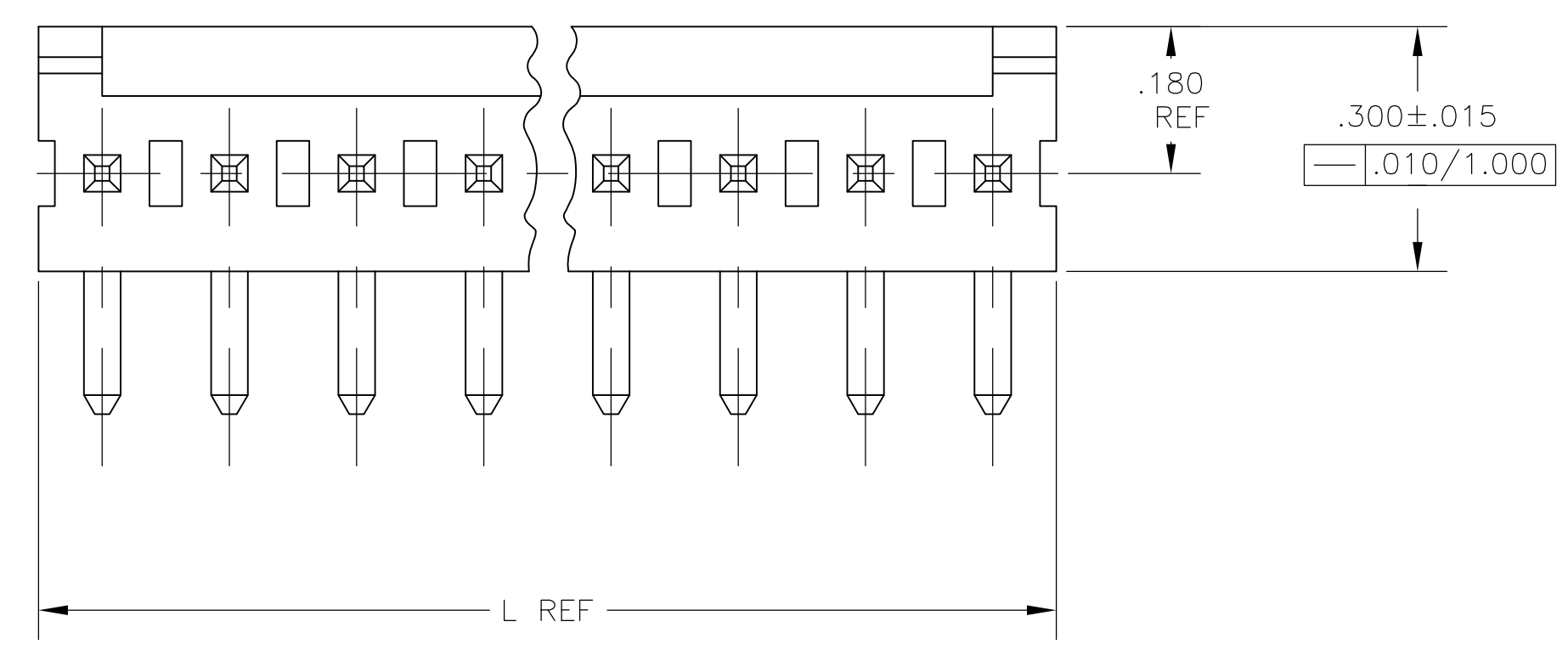

95.10	3.744	24	5-644754-4
91.14	3.588	23	5-644754-3
87.17	3.432	22	5-644754-2
83.21	3.276	21	5-644754-1
79.25	3.120	20	5-644754-0
75.29	2.964	19	4-644754-9
71.32	2.808	18	4-644754-8
67.36	2.652	17	4-644754-7
63.40	2.496	16	4-644754-6
59.44	2.340	15	4-644754-5
55.47	2.184	14	4-644754-4
51.51	2.028	13	4-644754-3
47.55	1.872	12	4-644754-2
43.59	1.716	11	4-644754-1
39.62	1.560	10	4-644754-0
35.66	1.404	9	3-644754-9
31.70	1.248	8	3-644754-8
27.74	1.092	7	3-644754-7
23.77	.936	6	3-644754-6
19.81	.780	5	3-644754-5
15.85	.624	4	3-644754-4
11.89	.468	3	3-644754-3
7.92	.312	2	3-644754-2
MM	[IN]	NUMBER OF POSITIONS	PART NUMBER
L			

14 SUPERSEDED	95.10	3.744	24	2-644754-4
	91.14	3.588	23	2-644754-3
	87.17	3.432	22	2-644754-2
	83.21	3.276	21	2-644754-1
	79.25	3.120	20	2-644754-0
	75.29	2.964	19	1-644754-9
	71.32	2.808	18	1-644754-8
	67.36	2.652	17	1-644754-7
	63.40	2.496	16	1-644754-6
	59.44	2.340	15	1-644754-5
	55.47	2.184	14	1-644754-4
	51.51	2.028	13	1-644754-3
	47.55	1.872	12	1-644754-2
	43.59	1.716	11	1-644754-1
39.62	1.560	10	1-644754-0	
35.66	1.404	9	644754-9	
31.70	1.248	8	644754-8	
27.74	1.092	7	644754-7	
23.77	.936	6	644754-6	
19.81	.780	5	644754-5	
15.85	.624	4	644754-4	
11.89	.468	3	644754-3	
7.92	.312	2	644754-2	
MM	[IN]	NUMBER OF POSITIONS	PART NUMBER	
L				

.070	1.78		
.068	1.73	1.000	25.40
.065	1.65	.450	11.43
.063	1.60	.425	10.80
.060	1.52	.400	10.16
.045	1.14	.345	8.76
.030	0.76	.325	8.26
.015	0.38	.300	7.62
.012	0.30	.212	5.38
.010	0.25	.180	4.57
.008	0.20	.175	4.45
.005	0.13	.156	3.96
.003	0.08	.125	3.18
.001	0.03	.078	1.98
.000	0.00	.073	1.85
IN	MM	IN	MM

CONVERSION TABLE

RECOMMENDED MOUNTING HOLE PATTERN FOR .109±.016 THICK P.C. BOARD

THIS DRAWING IS A CONTROLLED DOCUMENT.

DIMENSIONS: INCHES	TOLERANCES UNLESS OTHERWISE SPECIFIED:	0 PLC ± -	1 PLC ± -	2 PLC ± -	3 PLC ± .005	4 PLC ± -	ANGLES ± -
--------------------	--	-----------	-----------	-----------	--------------	-----------	------------

MATERIAL: A FINISH: 7

APPROVED: D. ROSSI 07NOV02
NAME: MTA-156 HEADER ASSEMBLY, FRICTION LOCK, RIGHT ANGLE, FRONT BEND .045, SQUARE POST, TIN PLATED, SPECIAL

SIZE: A1 CASE CODE: DRAWING NO: 00779 C=644754
RESTRICTED TO: -

CUSTOMER DRAWING SCALE: 5:1 SHEET 1 OF 1 REV: E2

单击下面可查看定价，库存，交付和生命周期等信息

[>>TE Connectivity\(泰科\)](#)