

NUMBER  
C-1734759



METRIC

THIS INFORMATION IS CONFIDENTIAL AND IS DISCLOSED TO YOU ON CONDITION THAT NO FURTHER DISCLOSURE IS MADE BY YOU TO OTHER THAN AMP PERSONNEL WITHOUT WRITTEN AUTHORIZATION FROM AMP (TAIWAN) LTD. DIMENSIONS IN MILLIMETERS. DO NOT SCALE PRINT.

PRINT  
DW

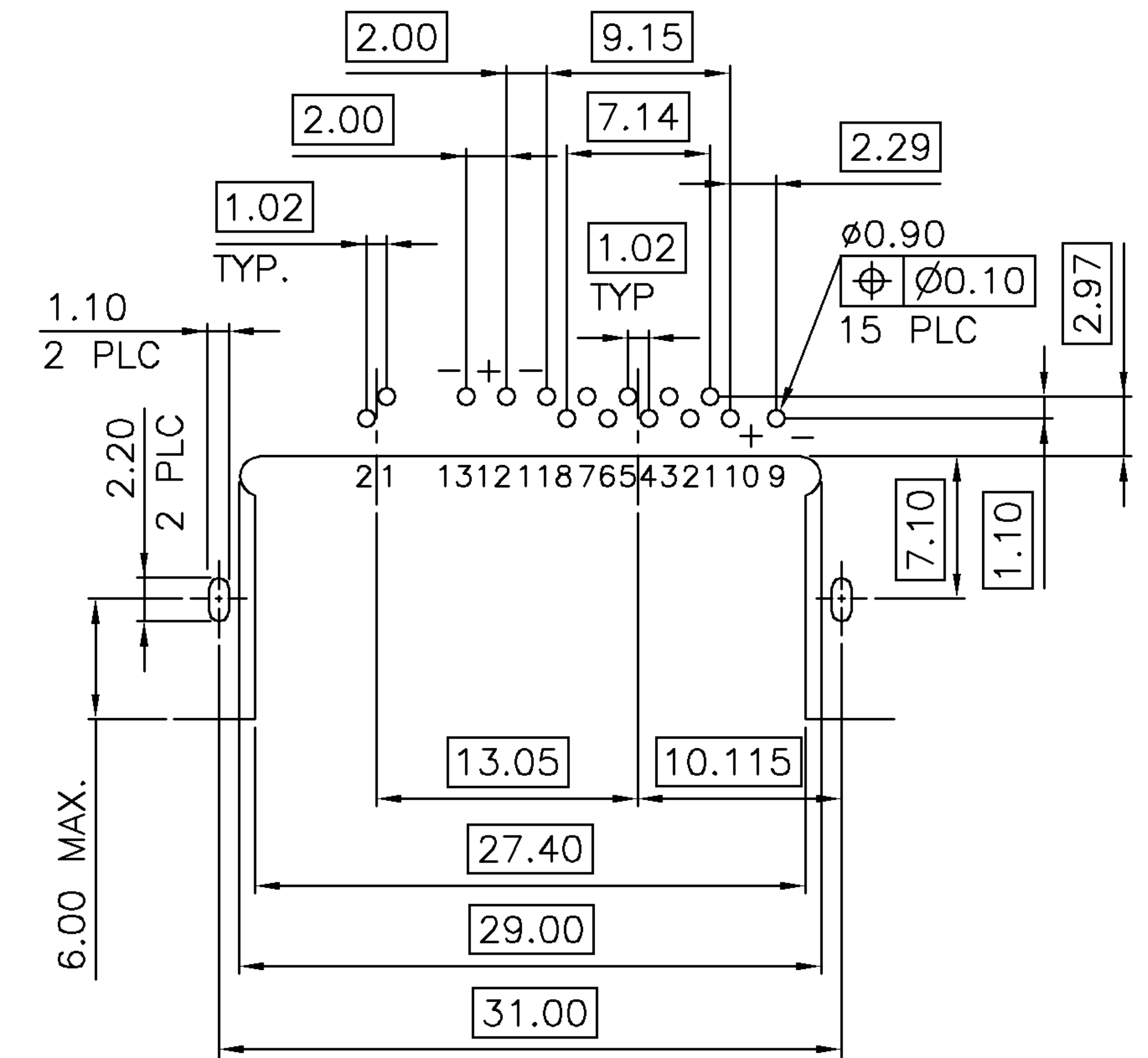
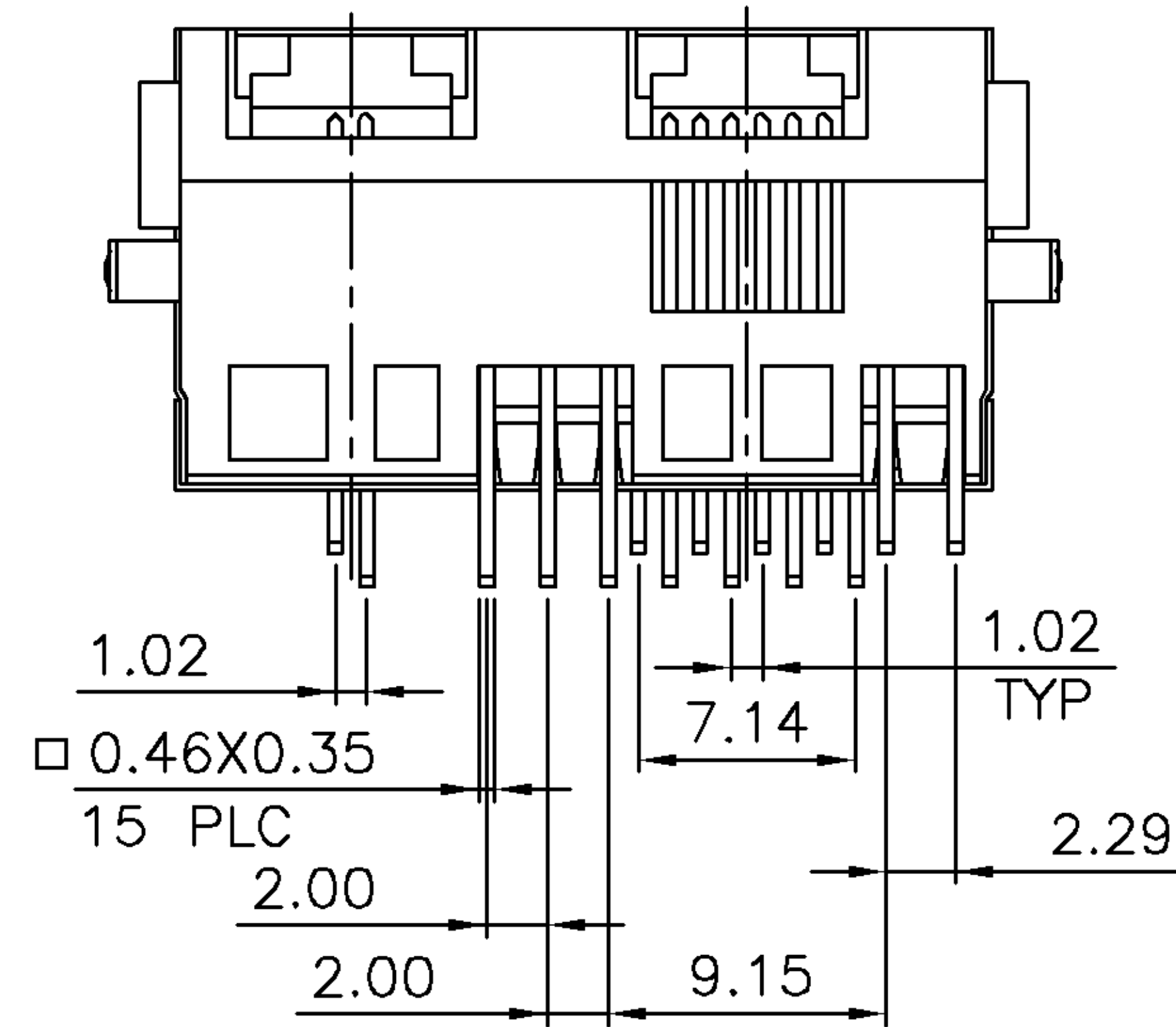
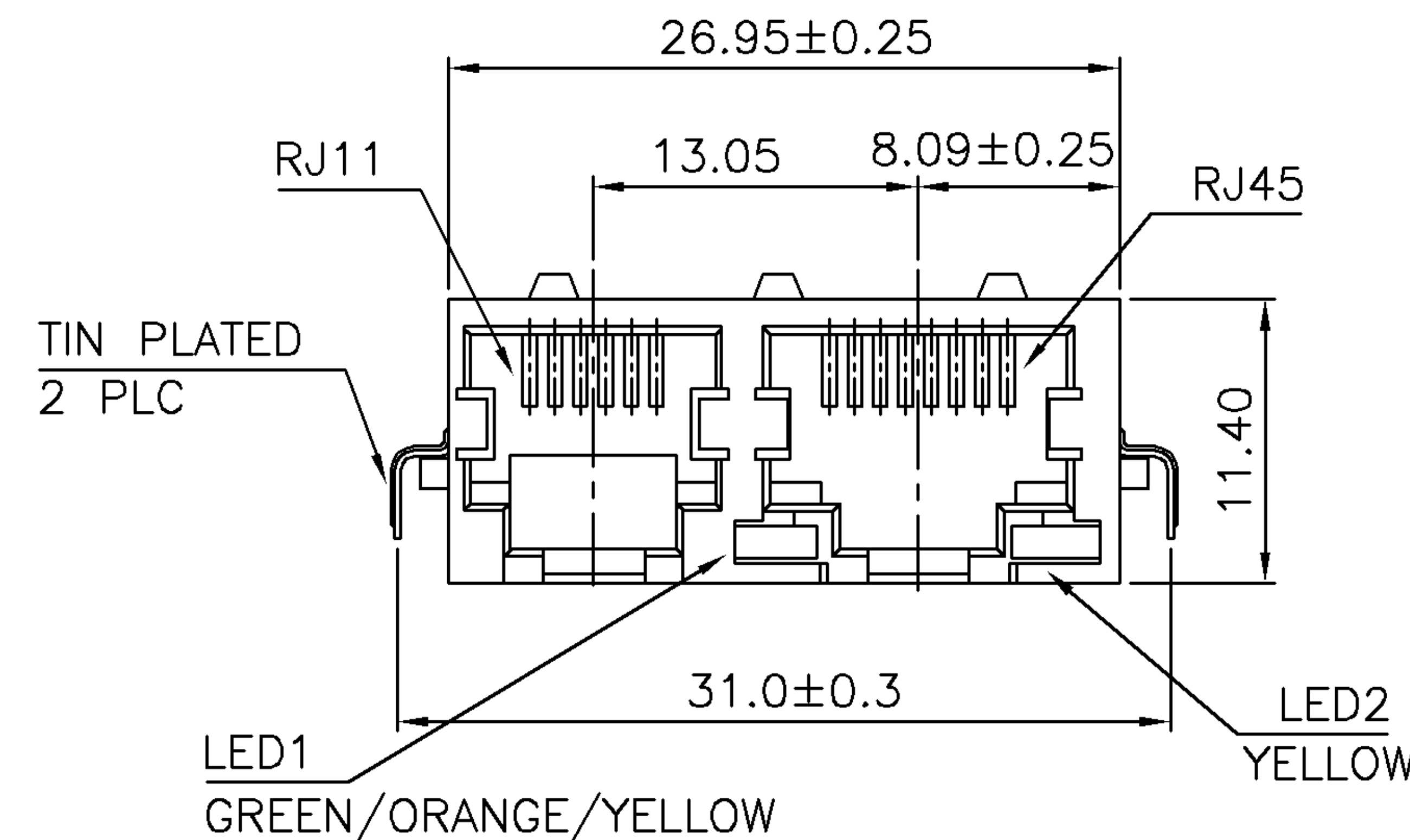
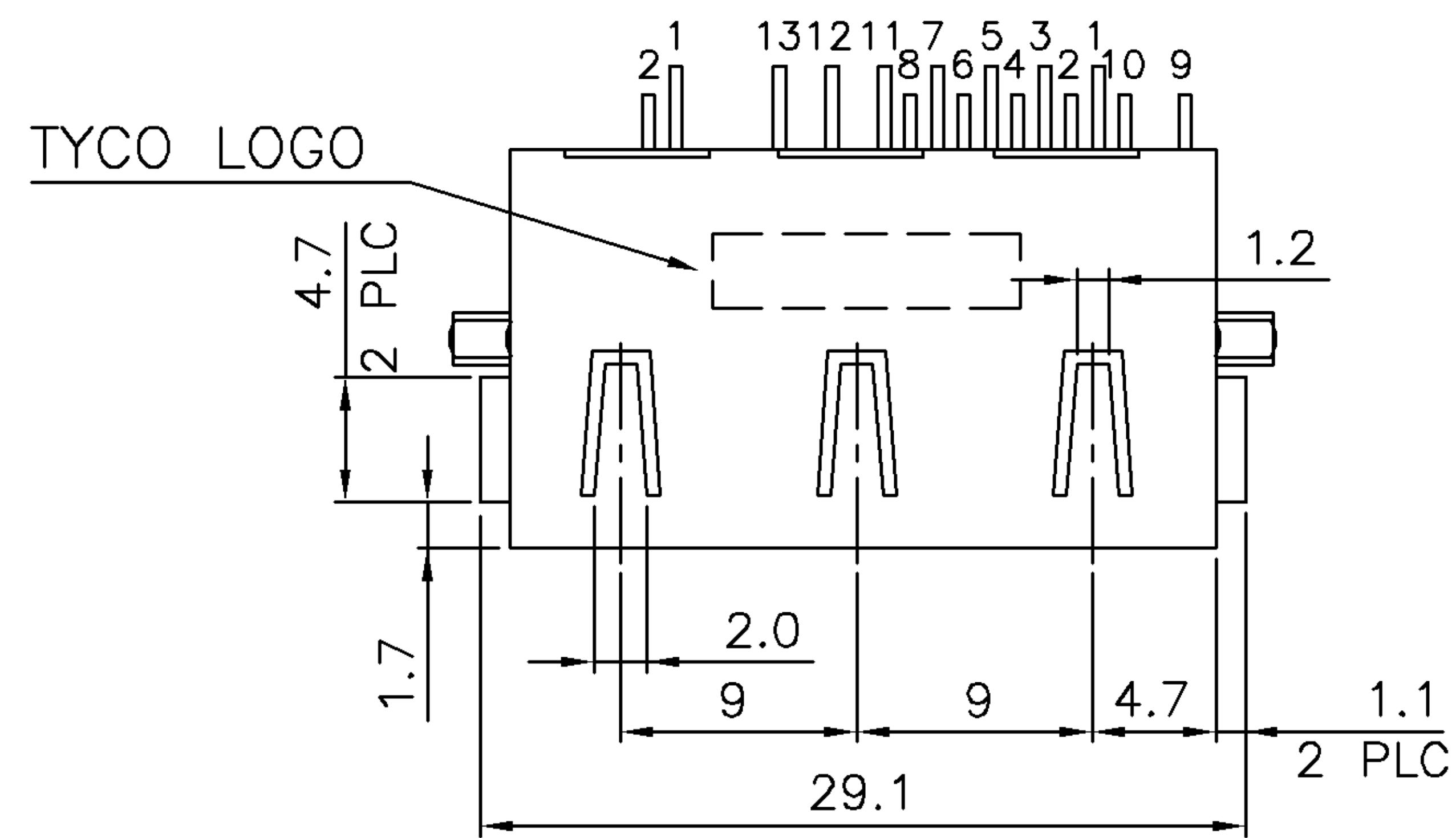
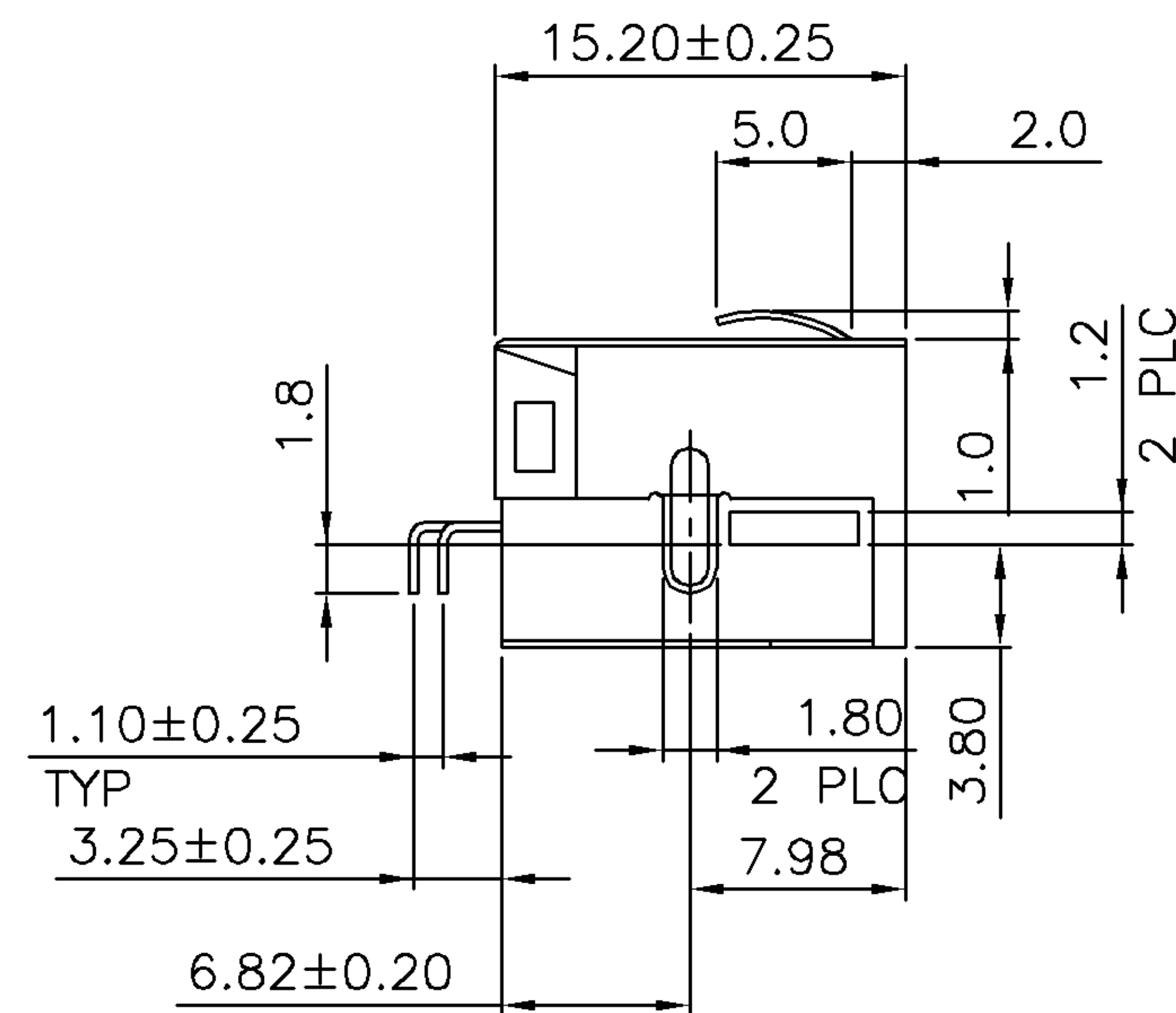

RECOMMENDED PCB LAYOUT (THICKNESS: 1.6mm)  
DIMENSION TOLERANCE: 1 PLC: ±0.1 2PLC: ±0.05

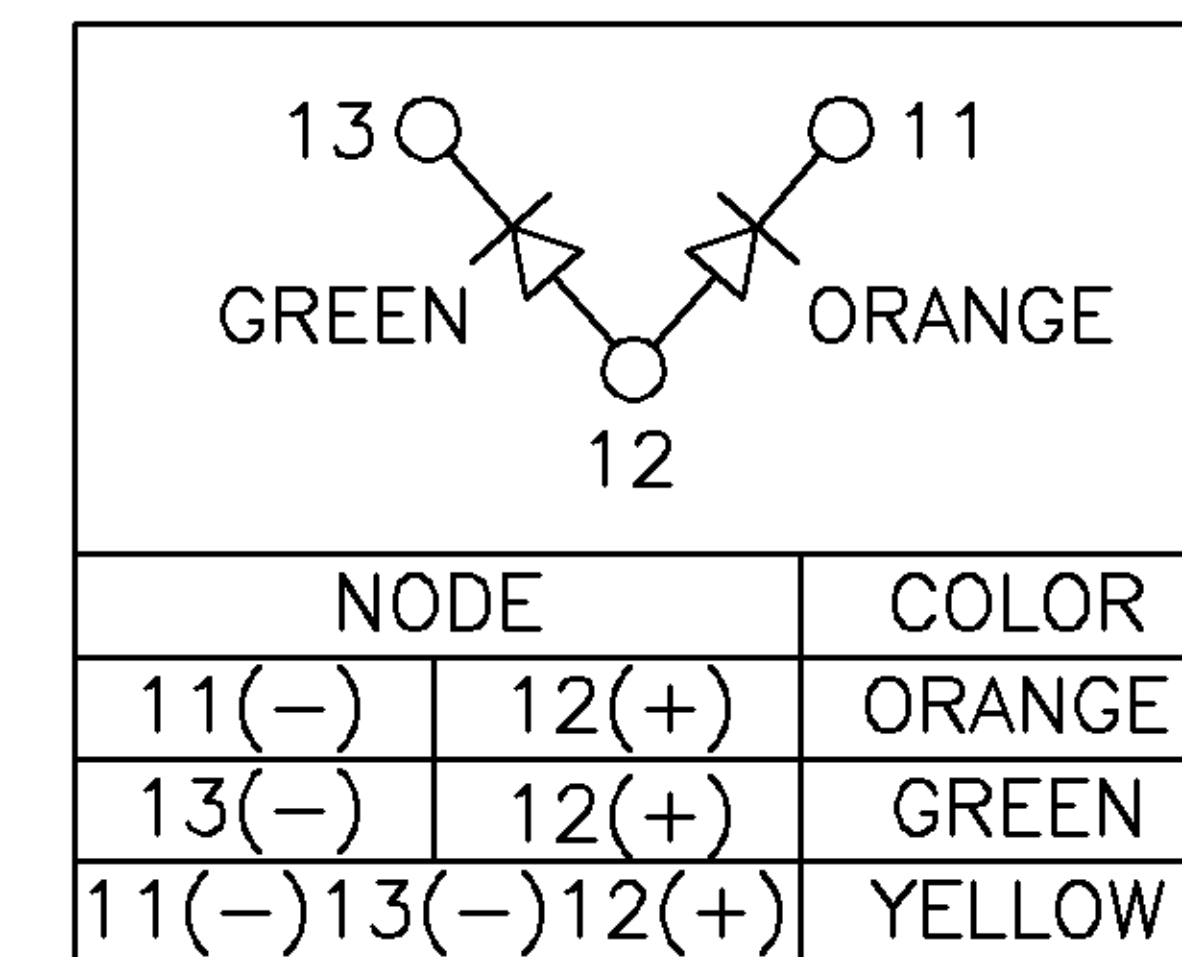

ELECTRICAL CIRCUIT

NOTE:

- MATERIAL:  
HOUSING: THERMOPLASTIC HIGH TEMP., UL 94V-0, COLOR: BLACK.  
CONTACT: PHOSPHOR BRONZE, THICKNESS: 0.35X0.46mm.  
SHIELD: BRASS, THICKNESS=0.20mm.  
LED LIGHT: EPOXY RESIN, THICKNESS: 0.50X0.50mm.
- FINISH:  
CONTACT: GOLD PLATED (SEE TABLE) IN CONTACT AREA, GOLD FLASH ON SOLDER TAILS, 50u" MIN NICKEL UNDERPLATED ALL OVER.  
SHIELD: 20u" MIN. NICKEL PLATED.  
LED LIGHT: 65u" MIN. Ag PLATED.  
85u" MIN. TIN PLATED.
- LED MUST BE REFLOW COMPATIBLE TO FOLLOWING TEMPERATURE PROFILE (FOR 1 CYCLE): ABOVE 160° FOR 120 SECONDS, PEAKING AT 260°C FOR 20~40 SECOND.
- LED DEFECT RATE IS 9000 PPM MAX. AFTER IR REFLOW PROCESS AS NOTE 3.
- WAVE SOLDER CAPABLE TO 265°C PER TYCO SPEC 109-202, CONDITION B.

6 OBSOLETE PARTS: OBSOLETE CIS STREAMLINING PER D.RENAUD/D.SINISI

01	REV PER ECO-09-026495	KK/AE	28NOV 2009
0	FIRST RELEASED	OH/SH	12AUG 2005
LTR	REVISION RECORD	DWN/CHK	DATE

TOLERANCES UNLESS OTHERWISE SPECIFIED: 0 PLC ±0.50 1 PLC ±0.30 2 PLC ±0.20 3 PLC ±0.10 ANGLES ±3'	DWN	O. HU	TYCO HOLDINGS (BERMUDA) VII LTD. TAIWAN BRANCH
	12-AUG-2005	12-AUG-2005	
MATERIAL SEE NOTE	CHK	S. HOU	MODULAR JACK, COMBO, RJ45/RJ11, WITH 3 COLORS LED, REVERSE, DIP TYPE
	APVD	W.J. KE	
FINISH SEE NOTE	PRODUCT SPEC	108-57535	LOC SIZE DRAWING NO REV DW A <sub>3</sub> C-1734759 01
	QUALIFICATION TEST REPORT	501-57625	
WEIGHT	5.0g	SCALE	SHEET 1 OF 2

6 OBSOLETE	50μ"	1734759-4
	30μ"	1734759-3
6 OBSOLETE	15μ"	1734759-2
	6μ"	1734759-1
	MIN. GOLD THICKNESS	PART NUMBER

NUMBER  
C-1734759

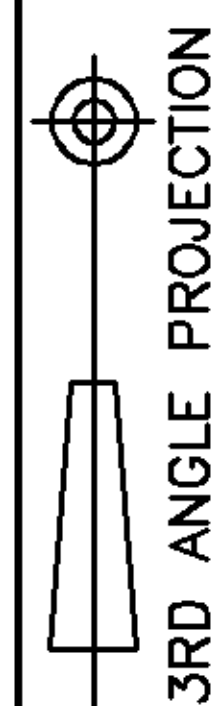

METRIC

THIS INFORMATION IS CONFIDENTIAL AND IS DISCLOSED TO YOU ON CONDITION THAT NO FURTHER DISCLOSURE IS MADE BY YOU TO OTHER THAN AMP PERSONNEL WITHOUT WRITTEN AUTHORIZATION FROM AMP (TAIWAN) LTD. DIMENSIONS IN MILLIMETERS. DO NOT SCALE PRINT.

PRINT  
DW

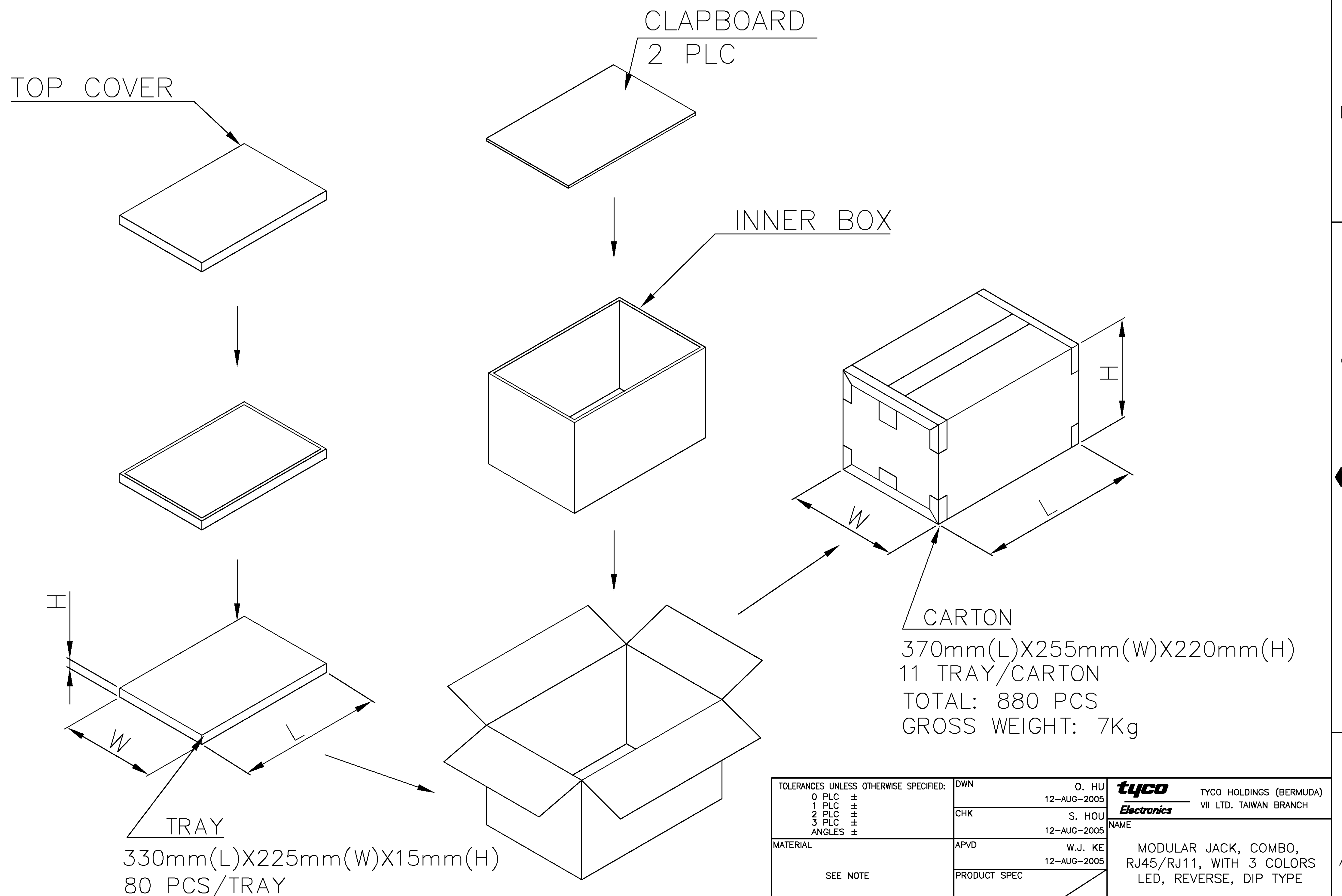

TOLERANCES UNLESS OTHERWISE SPECIFIED:		DWN	O. HU	<b>tyco</b> TYCO HOLDINGS (BERMUDA)	
0 PLC	±		12-AUG-2005	VII LTD. TAIWAN BRANCH	
1 PLC	±	CHK	S. HOU	NAME	
2 PLC	±		12-AUG-2005		
3 PLC	±			MODULAR JACK, COMBO, RJ45/RJ11, WITH 3 COLORS LED, REVERSE, DIP TYPE	
ANGLES	±				
MATERIAL	SEE NOTE	APVD	W.J. KE	LOC SIZE DRAWING NO REV DW C-1734759 01	
		PRODUCT SPEC	12-AUG-2005		
FINISH	SEE NOTE	QUALIFICATION TEST REPORT		SCALE SHEET -- 2 OF 2	
		WEIGHT			

SEE SHEET 1.		ECN	DWN	CHK	DATE
LTR	REVISION RECORD				

单击下面可查看定价，库存，交付和生命周期等信息

[>>TE Connectivity\(泰科\)](#)