

THIS DRAWING IS UNPUBLISHED. RELEASED FOR PUBLICATION
 © COPYRIGHT BY TYCO ELECTRONICS CORPORATION. ALL RIGHTS RESERVED.

LOC	DIST	REVISIONS					
GP	00	P	LTR	DESCRIPTION	DATE	DWN	APVD
		F		ADDED 9--0 PER EC 0S12-0217-03	12MAY03	AWF	AWF
		F1		REVISED PER ECO-09-020689	25AUG09	KK	AEG

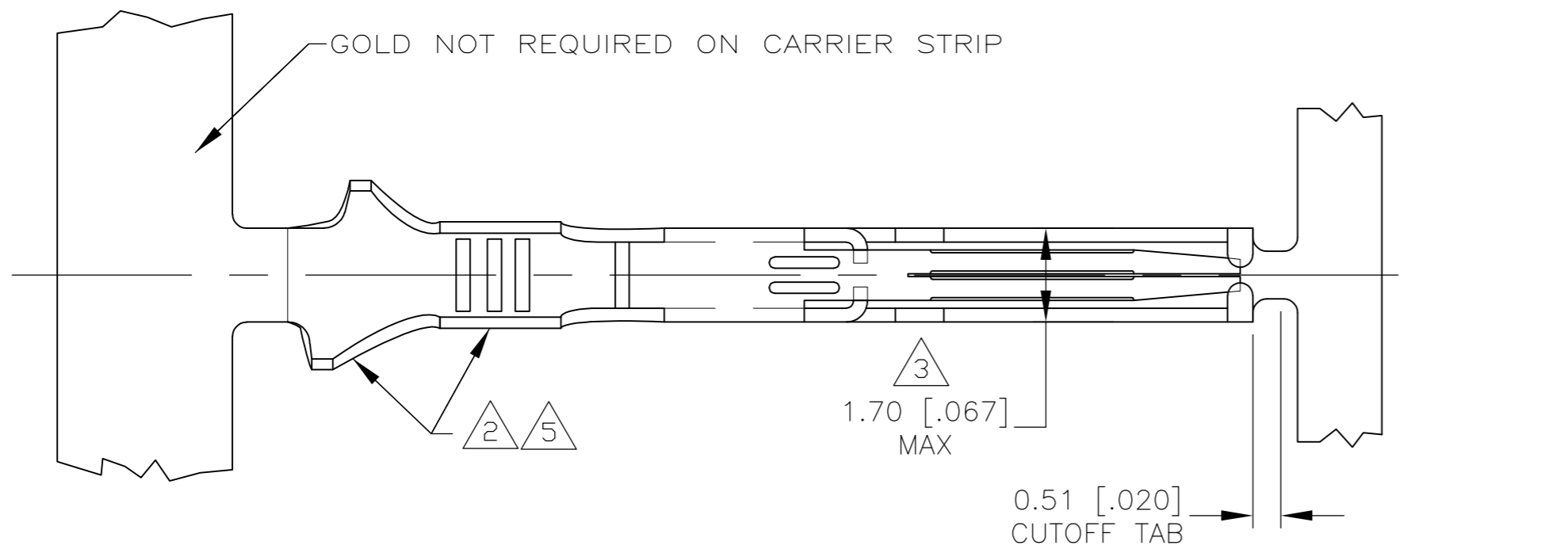

- 1 0.76 μ m [.000030] MIN GOLD OVER 0.76 μ m [.000030] MIN NICKEL IN CONTACT AREA.
- 2 TIN-LEAD IN CRIMP AREA.
- 3 .067 MAX ALLOWED IN LOCKING LANCE AREA.
- 4 REEL QUANTITY = 7000 PIECES.
- 5 TIN PLATE IN CRIMP AREA.
- 6 OBSOLETE PARTS: OBSOLETE CIS STREAMLINING PER D.RENAUD/D.SINISI

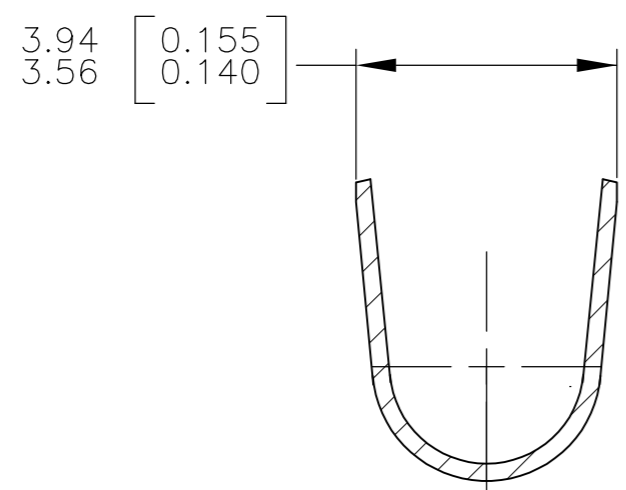
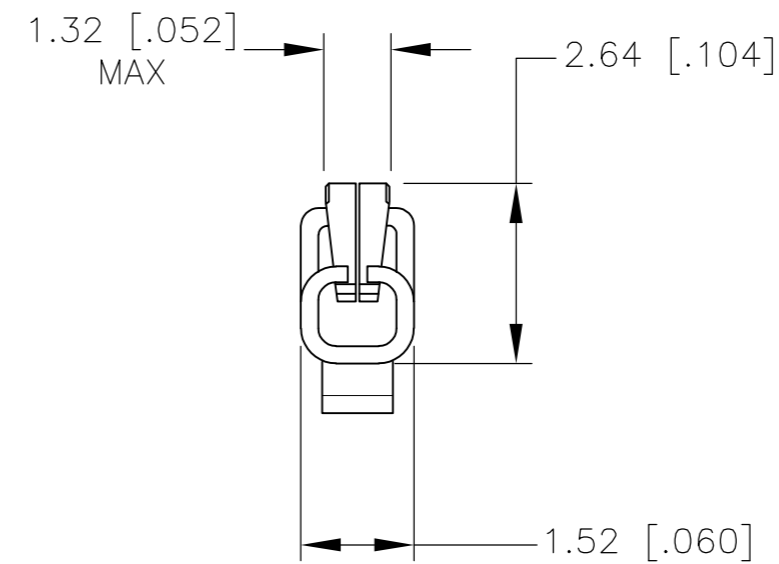
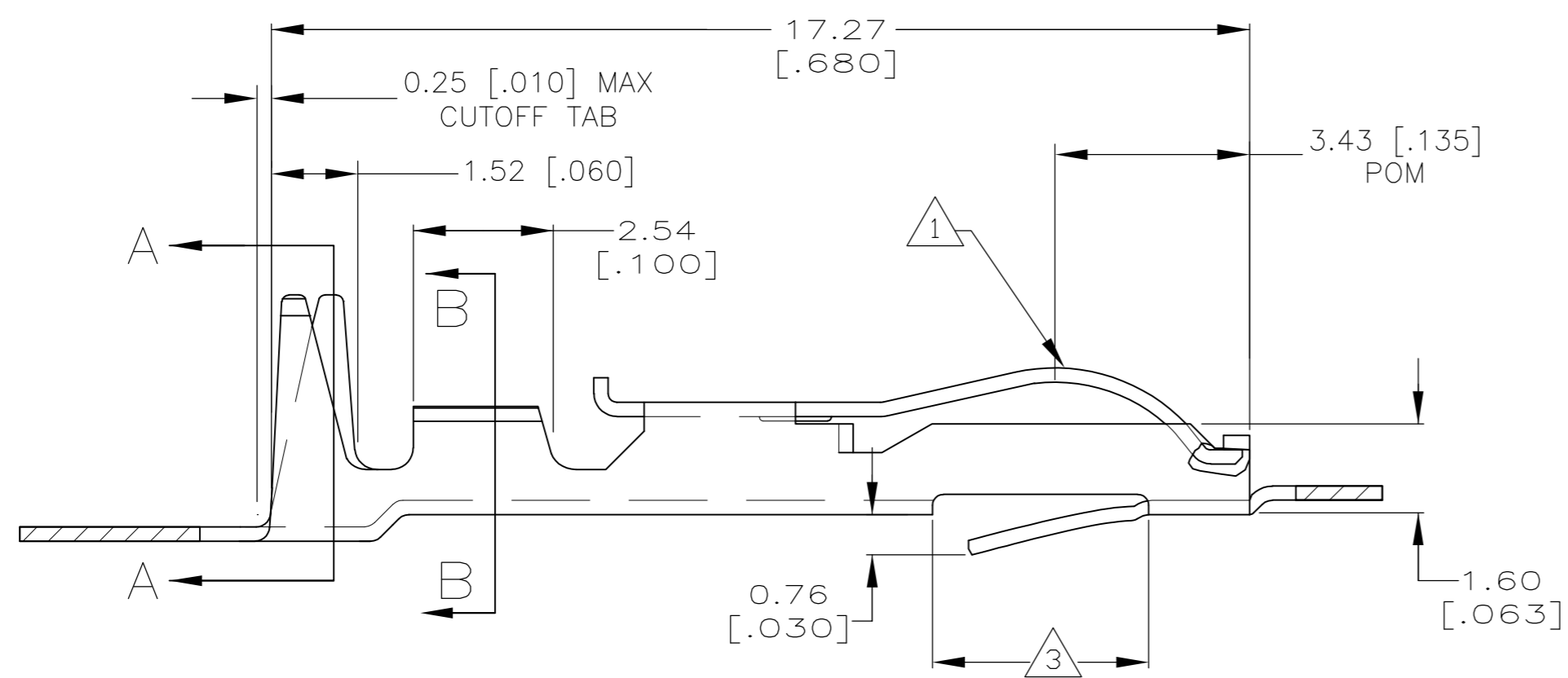

SECTION A-A
 INSULATION RANGE
 .100-.121 DIA

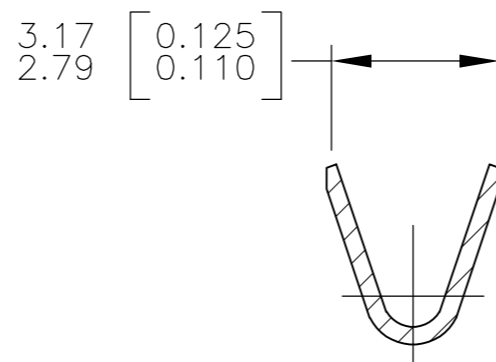

SECTION B-B
 WIRE RANGE
 #20-16

6 SUPERSEDED 1 5 9-147431-0

1 2 147431-2
 FINISH PART

THIS DRAWING IS A CONTROLLED DOCUMENT.		DWN A.STAUB BG 31JUL00	Tyco Electronics Corporation Harrisburg, PA, 17105	
DIMENSIONS: INCHES		CHK M.MILLER 08 MAR 00	NAME M.MILLER 08 MAR 00	
TOLERANCES UNLESS OTHERWISE SPECIFIED:		APVD M.MILLER 08 MAR 00	PRODUCT SPEC	
0 PLC ± -		APPLICATION SPEC		
1 PLC ± -		SIZE A2		
2 PLC ± 0.13 [.005]		CAGE CODE 00779		
3 PLC ± -		DRAWING NO C=147431		
4 PLC ± -		RESTRICTED TO		
ANGLES ± -		SCALE 10:1		
FINISH		SHEET 1 OF 1		
MATERIAL COPPER ALLOY		REV F1		
CUSTOMER DRAWING				

单击下面可查看定价，库存，交付和生命周期等信息

[>>TE Connectivity\(泰科\)](#)