

THIS DRAWING IS UNPUBLISHED. RELEASED FOR PUBLICATION
 © COPYRIGHT BY TYCO ELECTRONICS CORPORATION. ALL RIGHTS RESERVED.

LOC	DIST	REVISIONS			
P	LTR	DESCRIPTION	DATE	DWN	APVD
AD	00	B1	REVISED PER ECO-08-019381	07AUG08	HMR MW

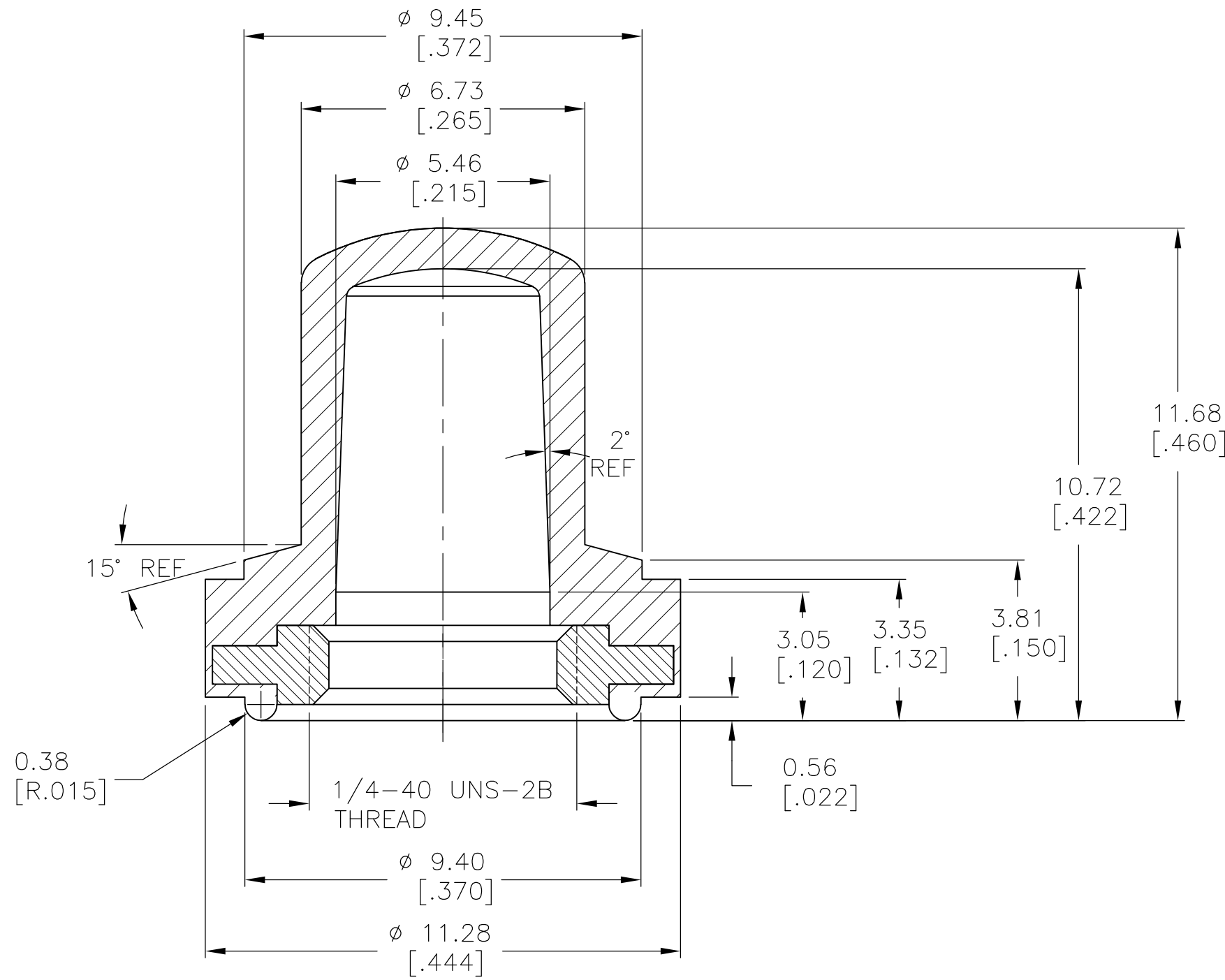
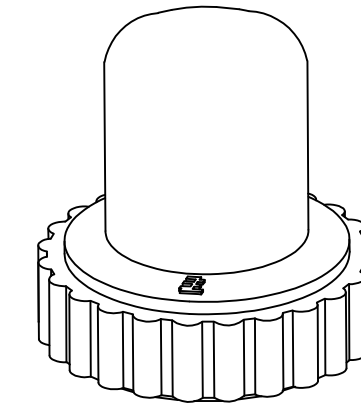
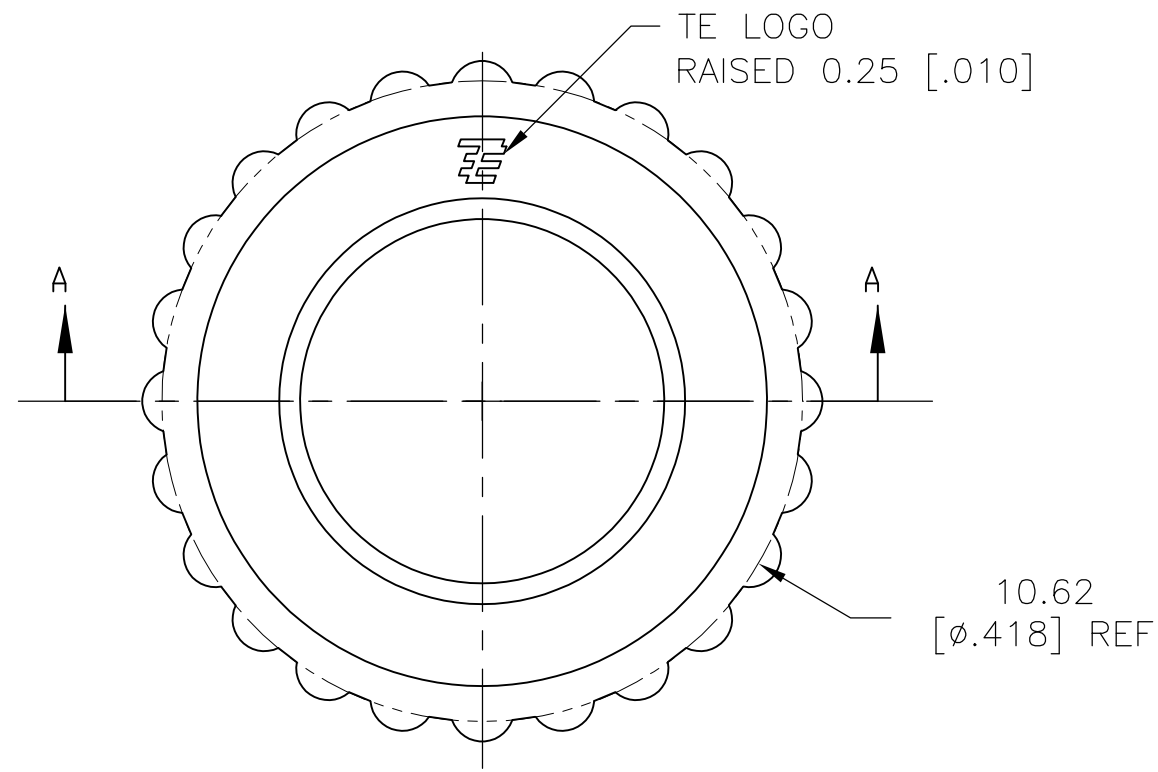

1. SOME DIMENSIONS MAY VARY DUE TO DIFFERENT COMPOUND SHRINKAGE FACTOR.
2. MINOR FLASH ACCEPTABLE ON INSERT THREAD.
3. BLACK FINISH ON INSIDE THREADS REMOVED DUE TO MOLDING PROCESS PERMITTED.
4. RUBBER TO METAL BOND MUST MEET OR EXCEED THE TEAR STRENGTH OF RUBBER.
5. SMALL PROTRUSIONS OF HEX NUT CORNERS PERMISSIBLE
6. ALL MATERIAL AND FINISHED SHALL COMPLY WITH EO DIRECTIVE 2002/95/EC OF 27JAN2003 (ROHS)

SECTION A-A

SILICONE COLOR BLACK	BRASS, BLACK OXIDE	1825617-2
RUBBER BOOT MATERIAL	HEX NUT MATERIAL	PART NUMBER

THIS DRAWING IS A CONTROLLED DOCUMENT.		DWN M. BINNER 22AUG2007	Tyco Electronics Corporation Harrisburg, PA 17105-3608	
DIMENSIONS: mm [INCHES]		CHK M. WILBOURN 22AUG07	NAME BOOT SEAL, ROUND 1/4-40, PUSHBUTTON	
TOLERANCES UNLESS OTHERWISE SPECIFIED:		APVD M. WILBOURN 22AUG07	SIZE A2	CAGE CODE 00779
0 PLC ± - 1 PLC ± - 2 PLC ± 0.25[.010] 3 PLC ± - 4 PLC ± - ANGLES ± 5°		PRODUCT SPEC APPLICATION SPEC	DRAWING NO C=1825617	RESTRICTED TO
MATERIAL FINISH		WEIGHT -	SCALE 8:1	SHEET 1 of 1
		CUSTOMER DRAWING	REV B1	

单击下面可查看定价，库存，交付和生命周期等信息

[>>TE Connectivity\(泰科\)](#)