

REVISIONS				
P	LTR	DESCRIPTION	DATE	APVD
B		PACKAGING CHANGED FROM BLACK POLYURETHANE SPONGE TO TRAY	26FEB2018	RK PS

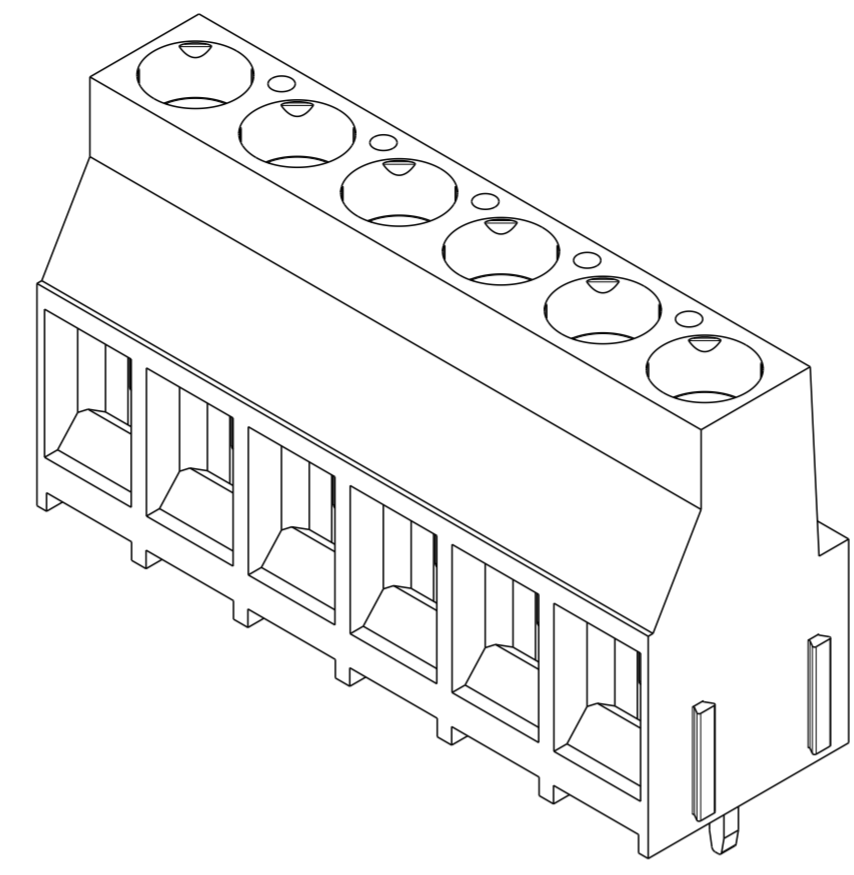
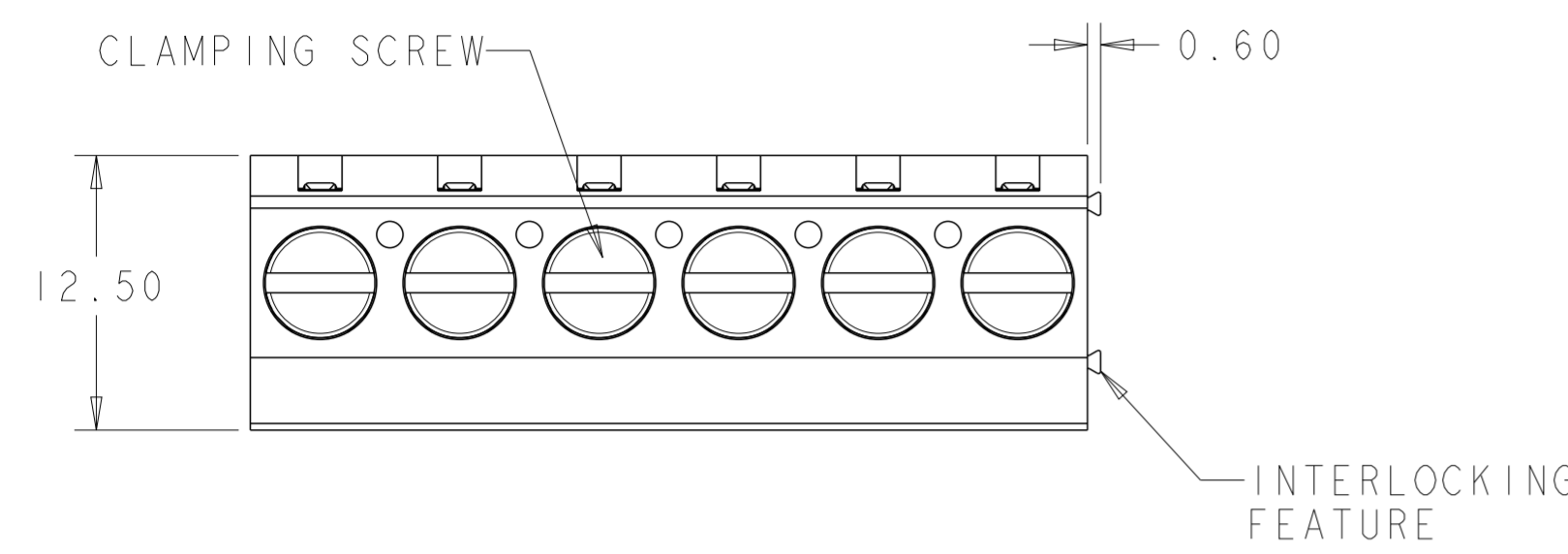

1546669-6 AS SHOWN

NOTES:

- MATERIALS AND FINISH:
 HOUSING: PA 6-6, UL 94-VO, COLOR: BLACK.
 CLAMP: BRASS, NICKEL PLATED.
 CLAMPING SCREW: M3.5, BRASS, NICKEL PLATED.
 TERMINAL: BRASS, TIN PLATED.
 - MECHANICAL
 WIRE STRIPPING LENGTH : 7.0-8.0 mm
 MIN. PC BOARD HOLES DIAMETER : 1.3 mm
 MAX. PC BOARD THICKNESS : 4.0 mm
 RECOMMENDED TIGHTENING TORQUE FOR SCREW: 0.8 Nm.
 - ELECTRICAL
 WIRE RANGE : 10-30 AWG
 MAX. VOLTAGE : 300 V
 MAX CURRENT : 30 A
 CONTACT RESISTANCE : <15 m Ohm
 INSULATION RESISTANCE : > 1000 M Ohm (500V DC)
 - OPERATING TEMPERATURE RANGE: -40°C TO +110°C
 - END-TO-END STACKABLE W/INTERLOCK, WITHOUT LOSS OF CENTERLINE SPACING.
 - PACKED IN TRAY.
- △ NOT CUMULATIVE TOLERANCE.

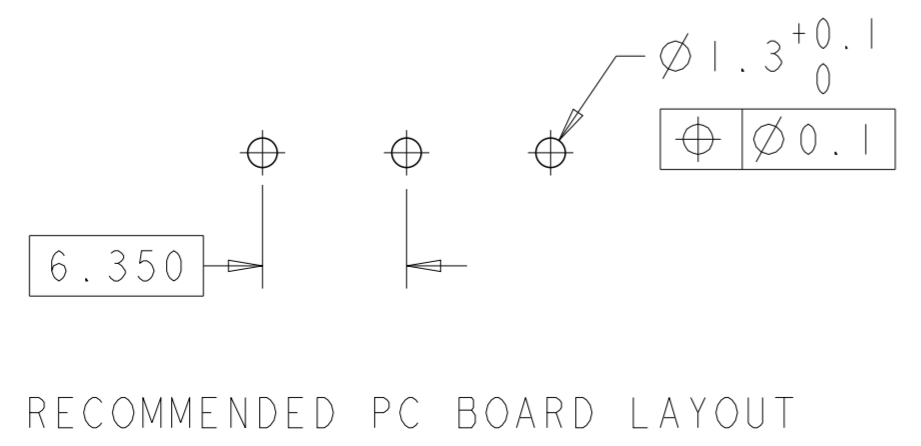
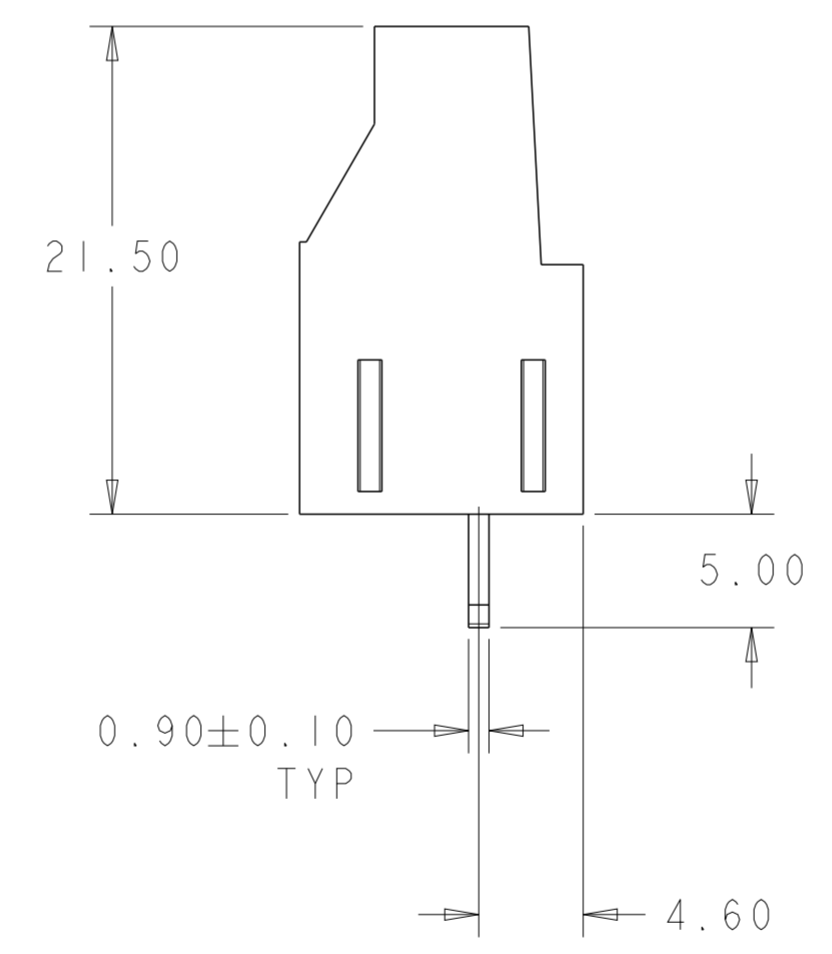
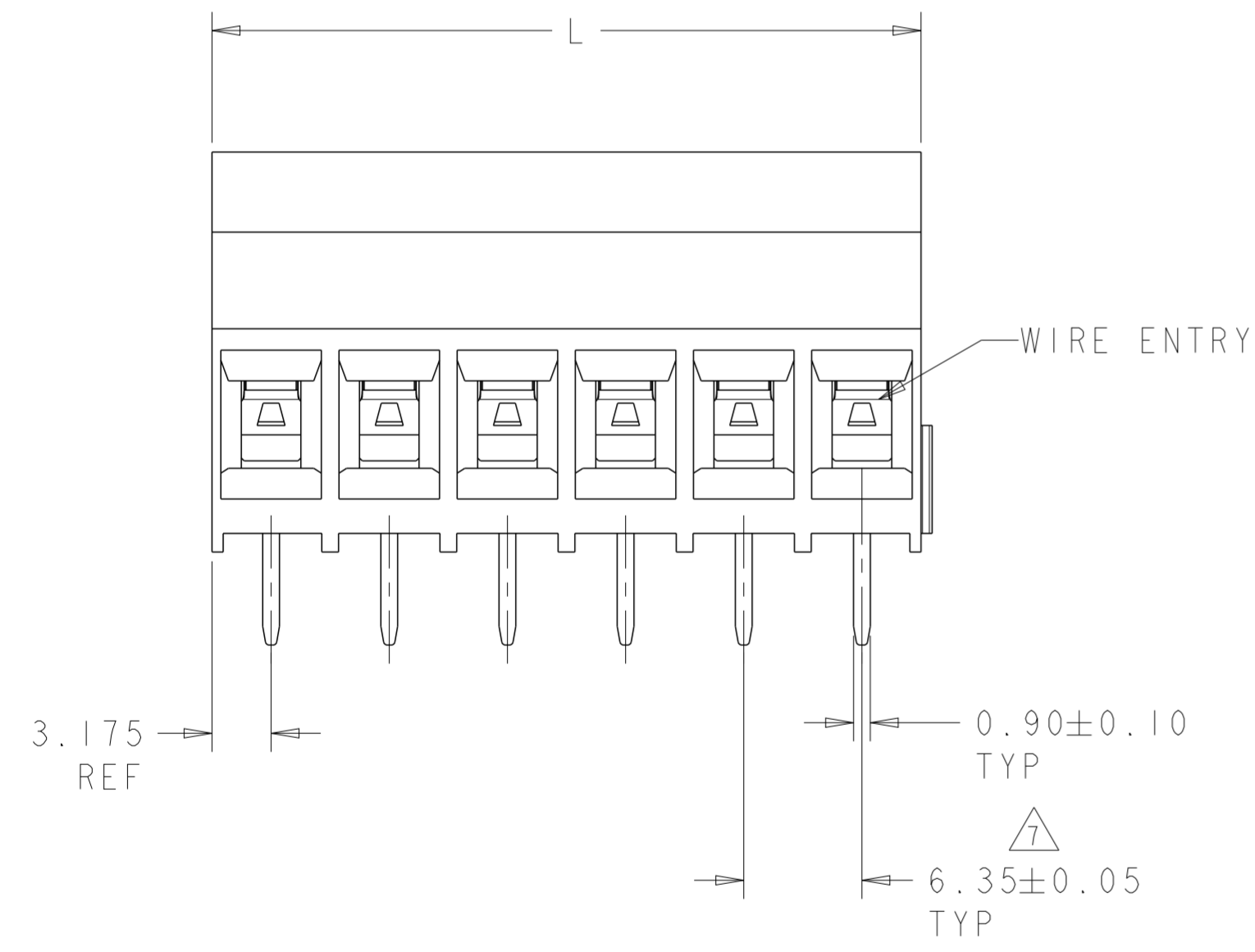

OBSOLETE	25.4	6	+546669-6
	6.35	2	1546669-2
	DIM "L"	NO OF POSN	PART NUMBER

THIS DRAWING IS A CONTROLLED DOCUMENT.		DWN S. WELDON 16 JUN 2003	STE TE Connectivity	
DIMENSIONS: mm		CHK C. RICHARD 16 JUN 2003		
TOLERANCES UNLESS OTHERWISE SPECIFIED:		APVD C. RICHARD 16 JUN 2003	NAME	
0 PLC ±0		PRODUCT SPEC	TERMINAL BLOCK, PCB MOUNT	
1 PLC ±0.2		APPLICATION SPEC	SIDE WIRE ENTRY, STACKING	
2 PLC ±0.20		WEIGHT	W/ INTERLOCK, 6.35mm PITCH	
3 PLC ±		SCALE	SIZE	RESTRICTED TO
4 PLC ±		3:1	A2	
ANGLES ±2		SHEET	CAGE CODE	OF
FINISH		1	1546669	1
MATERIAL SEE NOTE 1		CUSTOMER DRAWING	REV	B

单击下面可查看定价，库存，交付和生命周期等信息

[>>TE Connectivity\(泰科\)](#)