

DESIGNED FOR USE WITH .141 SR	
CABLE ENTRY DIAMETER MINIMUM	
SLEEVE	.142
CONTACT	.039

REVISIONS			
REV	DESCRIPTION	DATE	APPROVED
B	PER EC 0U20-0692-00	9/24/01	<i>C. Hoang</i> 9/24/01

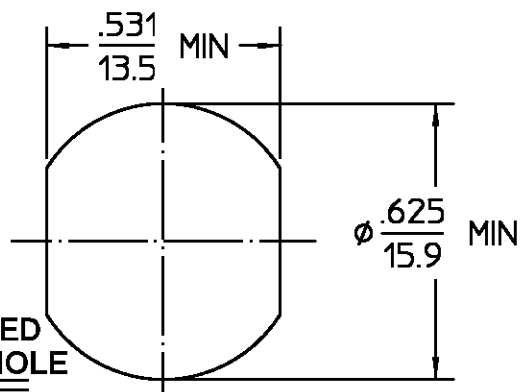
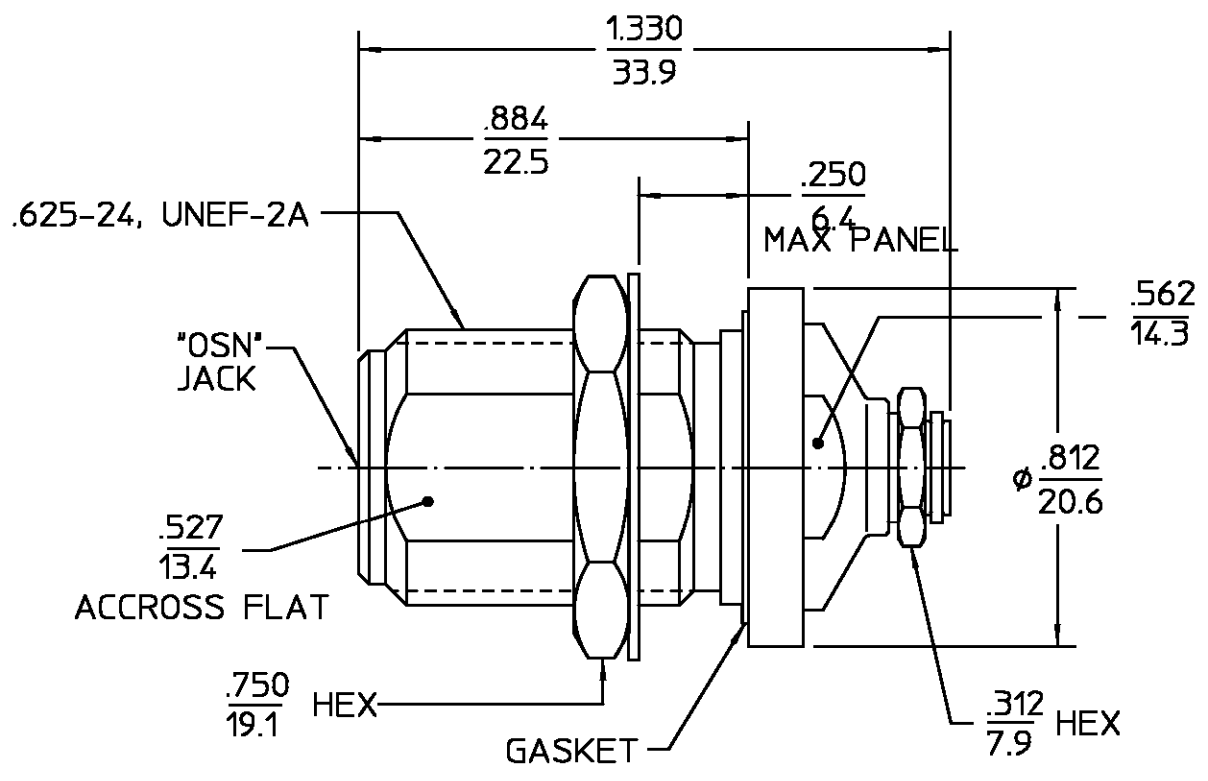

HOUSING MOUNTING NUT LOCKWASHER	STAINLESS STEEL PER ASTM-A484 AND ASTM-A582, TYPE 303	PASSIVATE PER QQ-P-35
CLAMP NUT	STAINLESS STEEL PER ASTM-A484 AND ASTM-A582, TYPE 303	GOLD PLATE PER MIL-G-45204
DIELECTRIC	PTFE FLUOROCARBON PER ASTM-D-1457	N/A
CENTER CONTACT	BRASS PER ASTM-B-16, HALF HARD	GOLD PLATE PER MIL-G-45204
CONTACT EXT.	BERYLLIUM COPPER PER ASTM-B-196 OR ASTM-B-197, ALLOY C17300, CONDITION H	GOLD PLATE PER MIL-G-45204
SLEEVE	BRASS PER ASTM-16, HALF HARD	GOLD PLATE PER MIL-G-45204
RETAINING RING	BERYLLIUM COPPER PER ASTM-B-194, ALLOY C17200, CONDITION H	GOLD PLATE PER MIL-G-45204
GASKET	SILICONE RUBBER PER ZZ-R-765	N/A

ELECTRICAL	MECHANICAL	ENVIRONMENTAL
Nominal Impedance (Ohms) <u>50</u>	Interface Dimensions MIL-STD-348A, Fig. <u>304-2</u>	Temperature Rating <u>-65 TO +165°C</u>
Frequency Range (GHz) DC to <u>11.0</u>	Recommended Mating Torque <u>6-10 IN-LBS</u>	Vibration MIL-STD-202, Method 204, Condition B
Volt Rating (VRMS MAX) @ Sea Level <u>1,000</u>	Mating Characteristics: Insertion (MAX Lbs) <u>2.0</u>	Shock MIL-STD-202, Method 213, Condition I
VSWR <u>1.06 + .007f(GHz)</u>	Withdrawal (MIN Oz) <u>2.0</u>	Thermal Shock MIL-STD-202, Method 107, Condition B, Except High Temp +85 °C
Insertion Loss (dB MAX) <u>.05√f(GHz)</u>	Force to Engage and Disengage (In-Lbs MAX) <u>6.0</u>	Moisture Resistance MIL-STD-202, Method 106
RF Leakage (dB MIN) <u>-(95-f(GHz))</u>	Center Contact Captivation: Axial (Lbs) <u>N/A</u>	Corrosion - MIL-STD-202, Method 101, Condition B, 5% salt spray
Corona, 70,000 Ft (VRMS MIN) <u>500</u>	Radial (In-Oz) <u>N/A</u>	
Dielectric Withstanding Voltage (VRMS MIN) @ Sea Level <u>2,500</u>	Cable Retention: Axial Force (Lbs) <u>60.0</u>	
Contact Resistance (Milliohms MAX): Center Contact <u>1.0</u>	Torque (In-Oz) <u>N/A</u>	
Outer Contact <u>2.0</u>	Weight (Grams) <u>TBD</u>	
Cable to Housing <u>N/A</u>		
RF High Potential @ Sea Level (VRMS MIN @ 5 MHz) <u>1,500</u>		
LR.(Megohms MIN) <u>10,000</u>		

COMPONENT	MATERIAL	FINISH
UNLESS OTHERWISE SPECIFIED DIMENSIONS ARE IN INCHES		
FRAC. ± 1/64	DEC. ± .005	ANGLES ± 1°
DRAWN BY PRB 8-7-67 CHECKED BY AJA 8-10-67 APPD BY D NANIA 8-14-67		AMP Incorporated 140 Fourth Avenue Waltham, MA 02451-7599
USE ASS'Y PROCEDURE 408-04903 NO. AP. (30-011)		TITLE 'OSN' STRAIGHT BULKHEAD FEEDTHRU CABLE JACK DIRECT SOLDER ATTACHMENT
SIZE B	CODE IDENT NO. 26805	3004-7841-00
SCALE 2.5:1	REV 052	SHEET 1 OF 1

.XXX = in
XX.X = mm (REF)

CUSTOMER DRAWING

AMP PART # 1057154-1
SHEET 1 OF 1 REV B

单击下面可查看定价，库存，交付和生命周期等信息

[>>TE Connectivity\(泰科\)](#)