

© 1967 BY AMP INCORPORATED. ALL RIGHTS RESERVED. AMP PRODUCTS COVERED BY PATENTS AND/OR PATENTS PENDING. APPROVED PER GOVT CONTRACT NO.

LOCATION FOR AMP-TAB FEMALE CONTACT

(1)-582589-1.1. SAME AS -1 EXCEPT TO HAVE CAVITY IDENTIFICATION ON TOP SURFACE OF HOUSING.

CAVITY IDENTIFICATION ON P/N (1)-582589-1 ONLY.

REVISIONS				
ZONE	LTR	DESCRIPTION	DATE	APPROVED
✓	Y	ECO-08-020973	PY 11-08	JW

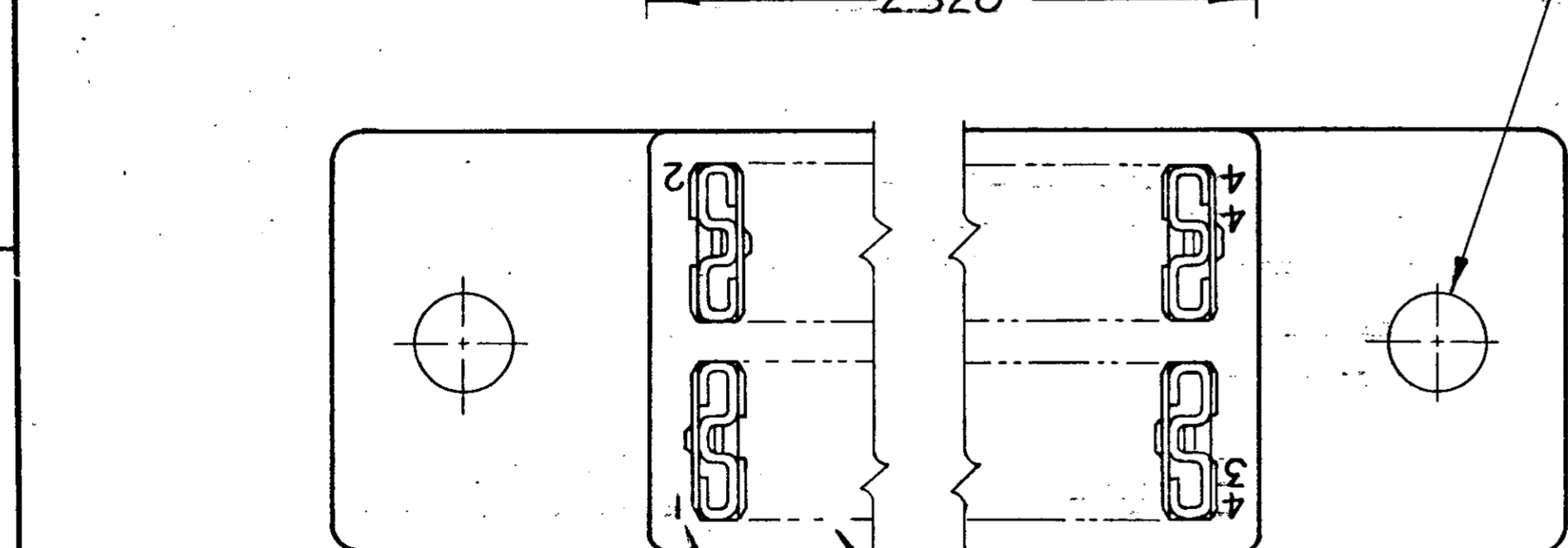
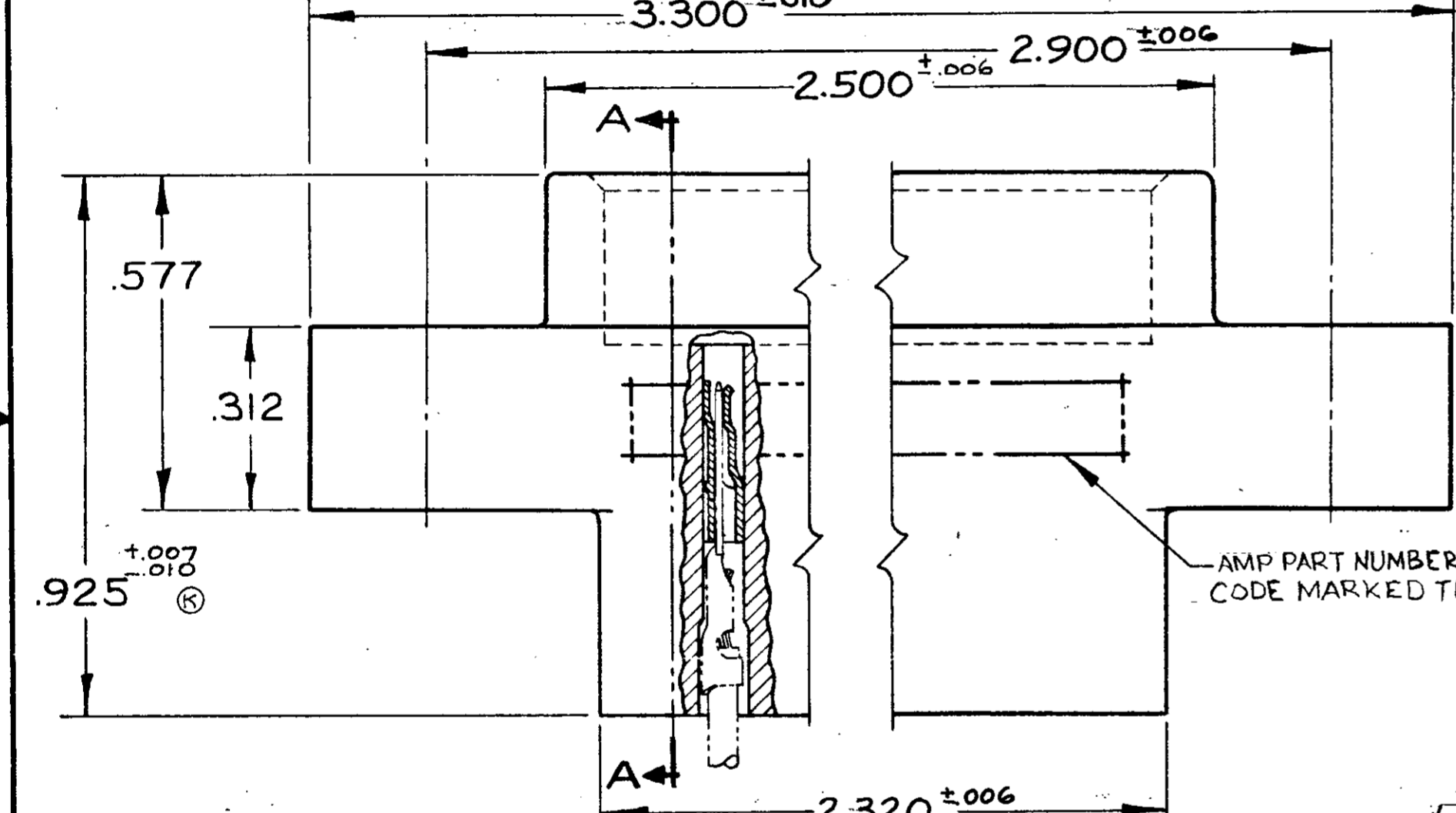
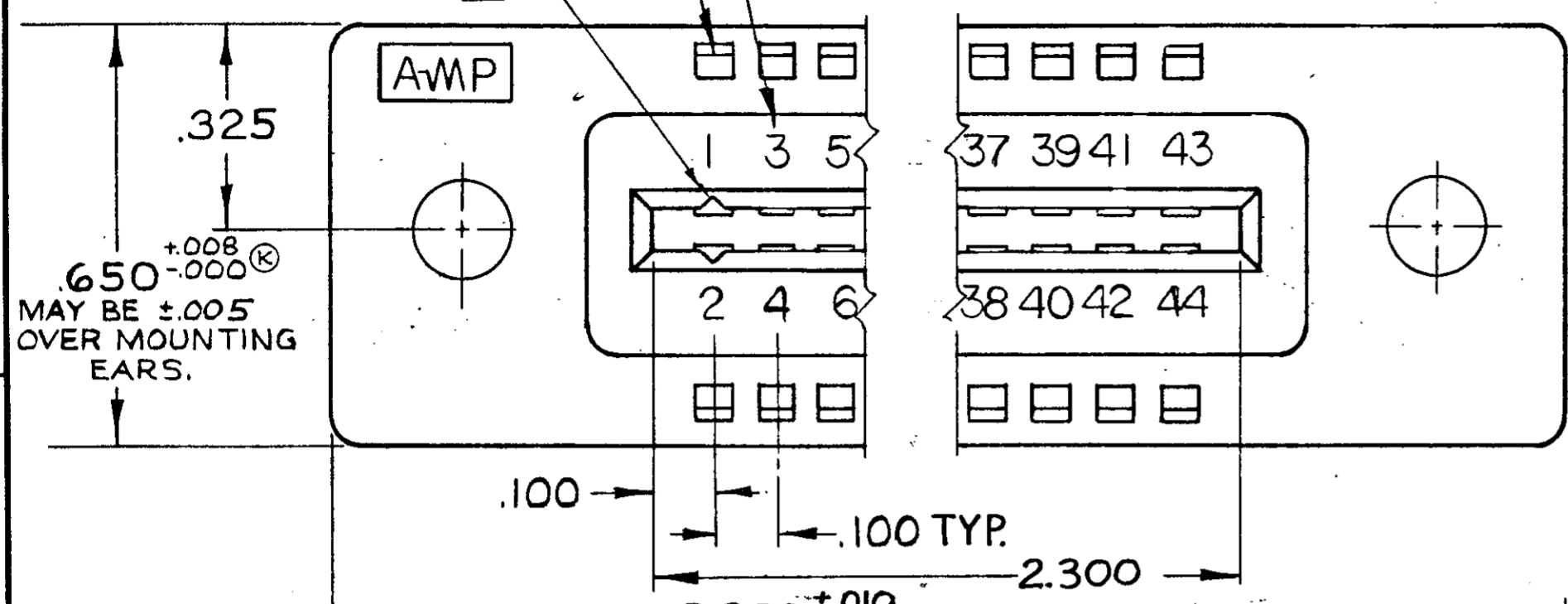

CIRCUIT CAVITY IDENTIFICATION MARKING PER MIL-C-21097

MARK FIRST 5 POSITIONS, NEXT 5 POSITIONS PLAIN

3. LASER MARKING ACCEPTABLE FOR ALL MARKING

△ GROOVES FOR "ON CONTACT KEYING" AMP'S OPTION DEPENDING ON METHOD OF MANUFACTURE. FOR "ON CONTACT" KEYING USE KEYING PLUG P/N 583487-1. (MUST BE ORDERED SEPARATELY.)

△ MOUNTING EAR CONFIGURATION AMP'S OPTION DEPENDS ON METHOD OF MANUFACTURE.

- 582589-1.1 AS SHOWN "J" DIA HOLES = .128
- OBS 582589-2.1 SAME AS -1 EXCEPT "J" DIA HOLES = .156
- OBS 582589-6 SAME AS 4 EXCEPT INK STAMPING ON TOP AND BOTTOM
- OBSOLETE 582589-4.1 SAME AS -1 EXCEPT: 2. FLOATING BUSHINGS
- OBS 582589-5.1 SAME AS 4 EXCEPT: FLOATING BUSHINGS REVERSED

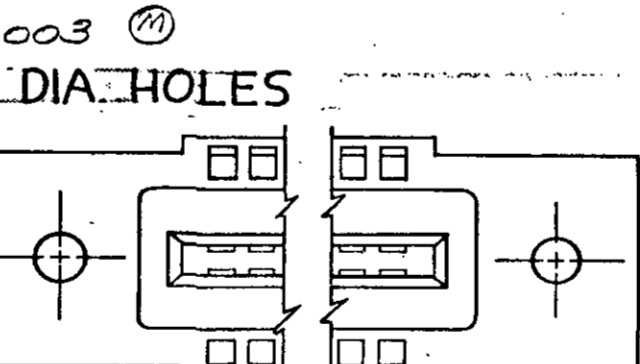
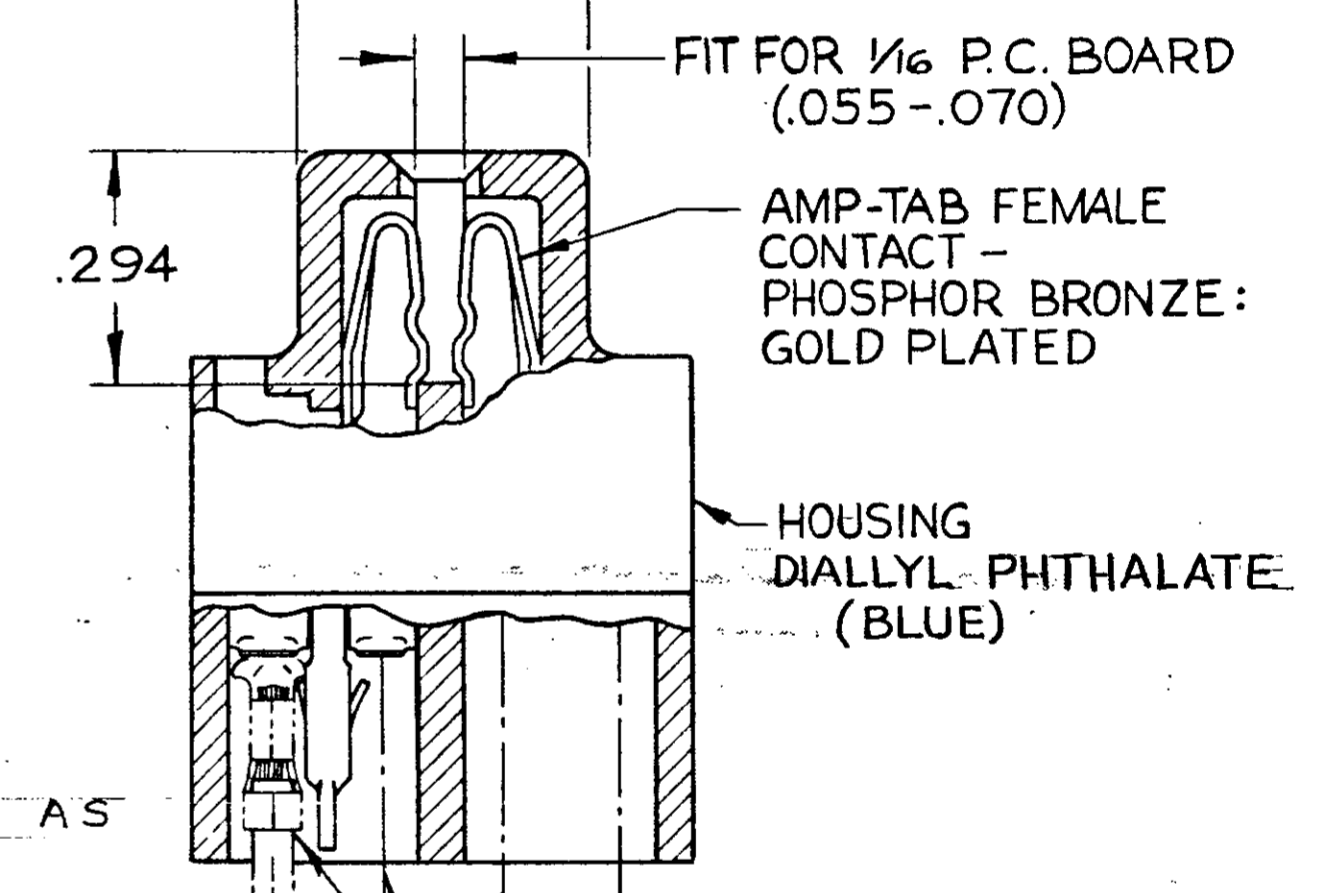
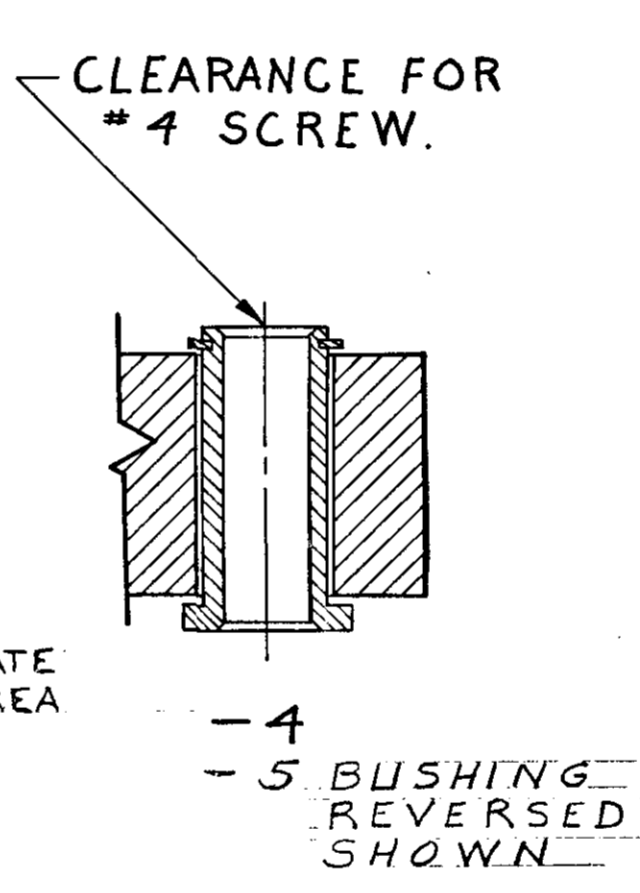

CONTACT #66143 OR #66144 (NOTE: MAX. WIRE SIZE #20) (MUST BE ORDERED SEPARATELY)

SECTION A-A

AMP INFO
LOC INT DIST
DF FO

UNLESS OTHERWISE SPECIFIED DIMENSIONS ARE IN INCHES TOLERANCES ON		CONTRACT NO	
FRACTIONS	DECIMALS	DR	DATE
±	±.005	<i>J. Asch</i>	12-16-66
ANGLES	±	CHK	DATE
±	±	<i>W. Burns</i>	1-5-67
MATERIAL		DSGN ENGR	DATE
SEE CALLOUT		APPD	DATE
HEAT TREAT		<i>J. Kaufman</i>	1-10-67
FINISH		DSGN APPD	DATE
SEE CALLOUT		<i>R. Showman</i>	1/10/67
OTHER APPD		DATE	

AMP INCORPORATED HARRISBURG, PENNSYLVANIA	
AMP TRADEMARK	
NAME 22 POSITION AMP-TAB CONNECTOR .100 CENTERS QUAD	
SIZE	NUMBER
C 00779	582589
SCALE 4-1	REV Y
WT	SHEET
CALC	ACTUAL

单击下面可查看定价，库存，交付和生命周期等信息

[>>TE Connectivity\(泰科\)](#)