

REVISIONS			
REV	DESCRIPTION	DATE	APPV
A	INITIAL RELEASE FROM X1	6-SEP-11	BPM
B	ADDED PART NUMBER TABLE AND SECOND SHEET; UPDATED NOTE 3	23-JUL-18	CLL

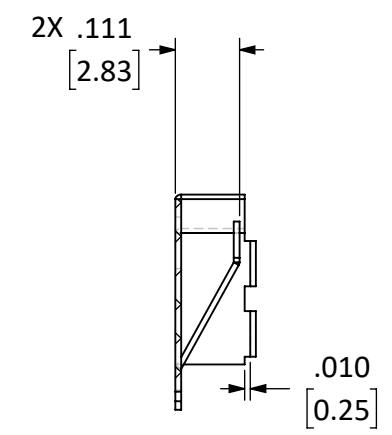

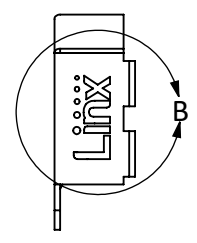
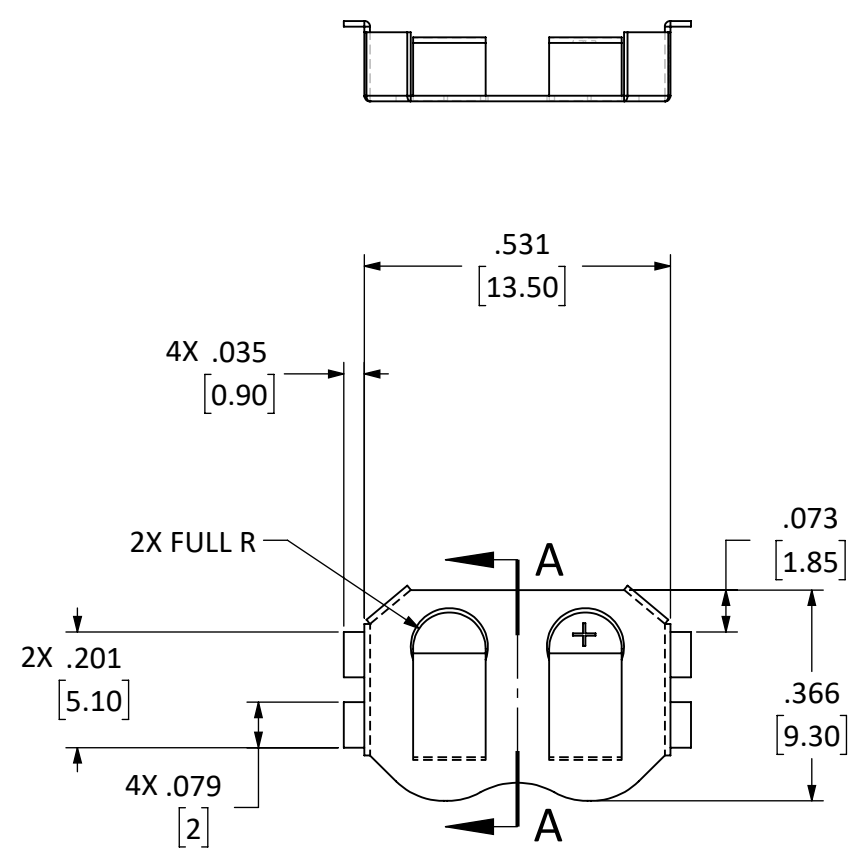
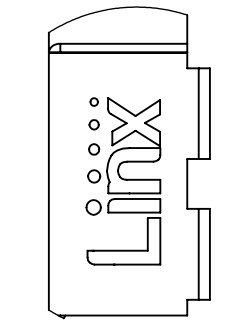
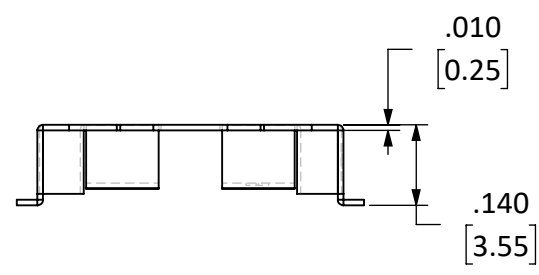

SECTION A-A

- NOTES: (UNLESS OTHERWISE SPECIFIED)
1. ALL DIMENSIONS ARE IN INCHES [mm].
 2. DIMENSIONS APPLY AFTER FINISHING.
 3. MANUFACTURE TO BE COMPLIANT WITH EU RoHS DIRECTIVE, USE MATERIALS THAT DO NOT CONTAIN REACH SUBSTANCES OF VERY HIGH CONCERN >1000ppm, AND USE DRC CONFLICT-FREE SOURCED MATERIALS.
 4. SAFETY BREAK ALL SHARP CORNERS AND EDGES .02 MAXIMUM.
 5. MINIMUM INSIDE BEND RADII 0.00 [0.0].
 6. EMBOSS LINX LOGO AS SHOWN, MINIMUM 0.002 [0.05] DEEP, PER FILE *LINX-LOGO-BLACK-ABBREVIATED.PDF*.

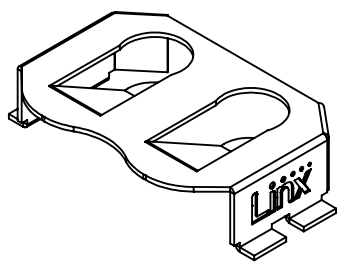

DETAIL B
SCALE 6 : 1



PART NUMBER		PACKAGING	
BAT-HLD-012-SMT		BULK	
BAT-HLD-012-SMT-TR		TAPE & REEL	
<p>WARNING: THIS DRAWING CONTAINS PROPRIETARY INFORMATION THAT IS THE SOLE PROPERTY OF LINX TECHNOLOGIES, AND SHALL BE TREATED AS SUCH. NO DISCLOSURE OR REPRODUCTION OF THIS DOCUMENT IS PERMITTED, IN WHOLE OR IN PART, WITHOUT THE EXPRESS WRITTEN PERMISSION OF LINX TECHNOLOGIES OR ITS DESIGNATED AGENTS.</p>		 <p>159 ORT LANE MERLIN, OR 97532</p>	
MATERIAL: PHOSPHOR BRONZE #C-5191	INTERPRET DIMENSIONS AND TOLERANCES PER ASME Y14.5. .X ±2.0 .XX ±1.0 .XXX ±.500	ANGLES: ±1° SURFACE: √	PROJECTION: 
WEIGHT:	DRAWN: S.HOGAN	DT: 8-JUN-11	TITLE: BATTERY HOLDER CR1216, CR1225, SURFACE MOUNT
FINISH: NICKEL PLATE	ENGR: S.HOGAN	DT: 23-JUL-18	SIZE DWG. NO. REV B C-BAT-HLD-012-SMT-pp A
SCALE: 3:1		DO NOT SCALE DRAWING	SHEET 1 OF 2

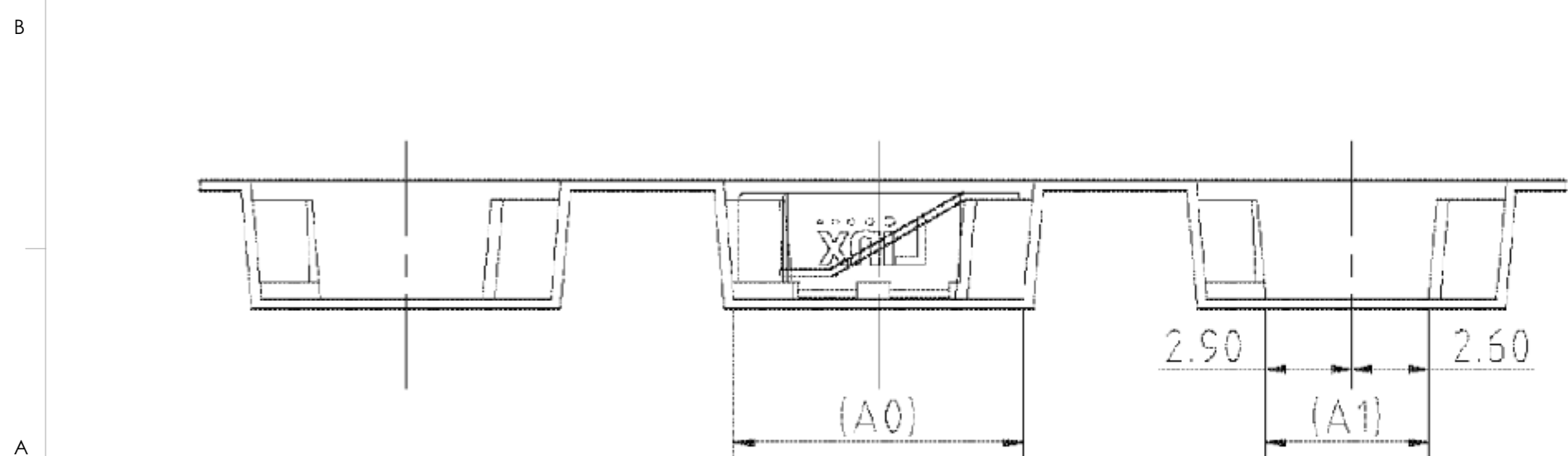
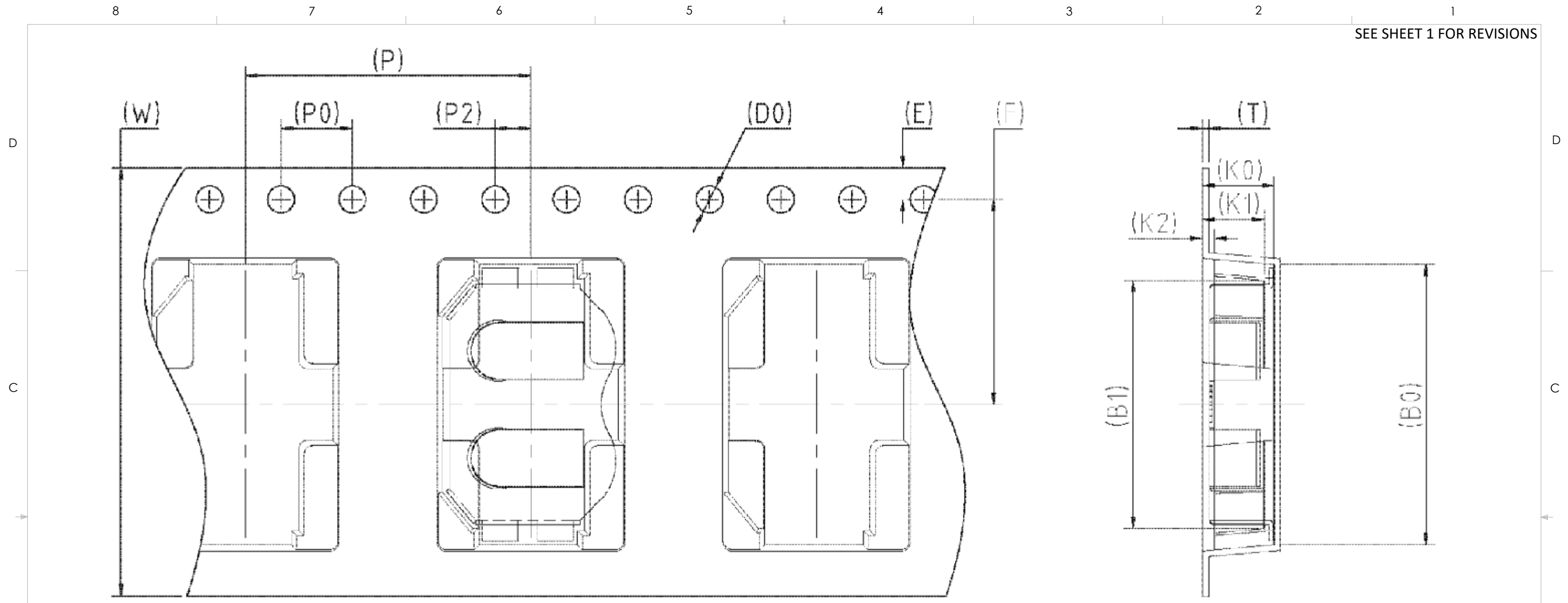

- NOTES: (UNLESS OTHERWISE SPECIFIED)
1. ALL DIMENSIONS ARE IN MILLIMETERS [INCHES].
 2. 10 SPROCKET HOLE PITCH CUMULATIVE TOLERANCE $\pm 0.2\text{mm}$.
 3. MATERIAL: BLACK POLYSTYRENE.
 4. PACKING LENGTH PER 22" REEL: 51.0 m.
 5. COMPONENT LOAD PER 13" REEL: 1000.
 6. ANGLE TOLERANCE: $\pm 1^\circ$
 7. CARRIER CAMBER IS WITHIN 1 mm IN 250 mm.

W	24.00±0.30	P	16.00±0.10	A0	9.80±0.10	B0	15.70±0.10
S		P0	4.00±0.10	A1	5.50±0.10	B1	13.90±0.10
E	1.75±0.10	P2	2.00±0.10	A2		B2	
F	11.50±0.10	D0	$\varnothing 1.50^{+0.10}_{-0.00}$	K0	4.00±0.10	K2	0.65±0.10
T	0.35±0.05	D1		K1	3.45±0.10	COLOR: BK/ANT	

SIZE	DWG. NO.	REV
B	BAT-HLD-012-SMT-TR	B
SCALE: 3:1	DO NOT SCALE DRAWING	SHEET 2 OF 2

单击下面可查看定价，库存，交付和生命周期等信息

[>>TE Connectivity\(泰科\)](#)