

REVISIONS

P	LTR	DESCRIPTION	DATE	DWN	APVD
A		INITIAL RELEASE	16APR2015	GY	CW
B		ECR-15-013759	12OCT2015	DW	CW
B1		ECR-16-015492	16NOV2016	QY	CW
C		ECR-21-106515	09JUL2021	SQ	CW

TYPE-1, T2040064101-000, TE LOGO
 类型-1, T2040064101-000, TE LOGO

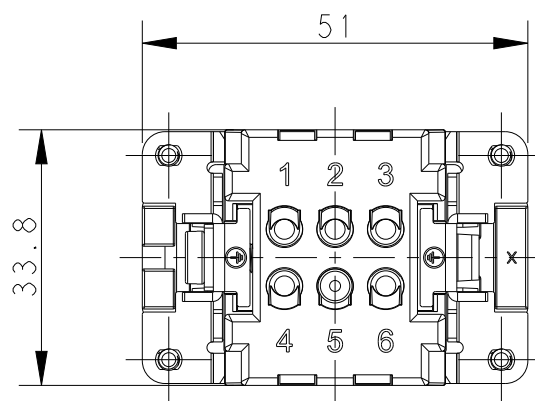
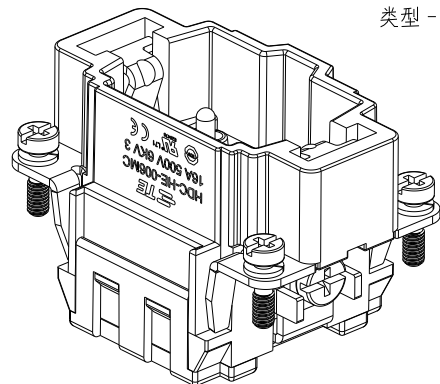

M4 SCREW, RECOMMENDED
 TIGHTENING TORQUE 1.2Nm
 M4螺丝, 推荐锁紧力矩 1.2Nm

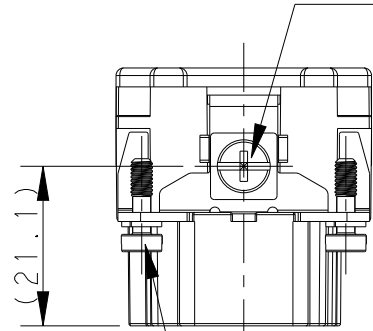

4X M3 SCREW, RECOMMENDED
 TIGHTENING TORQUE 0.5Nm
 4X M3螺丝, 推荐锁紧力矩 0.5Nm

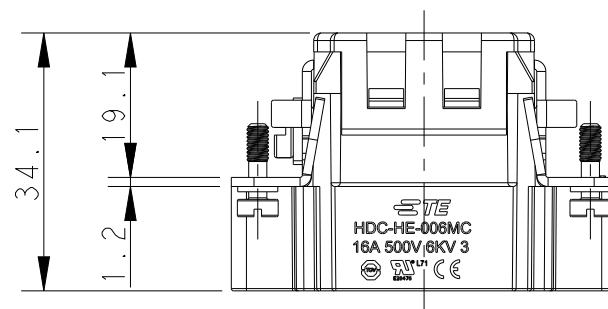

NOTES:

- TECHNICAL CHARACTERISTICS:
 INSULATION MATERIAL: PC
 RATED VOLTAGE: 500V
 RATED CURRENT: 16A
 INSULATION RESISTANCE: $\geq 400M\Omega$
 RATED IMPULSE VOLTAGE: 6KV
 POLLUTION DEGREE: 3
 FLAMMABILITY: UL94V-0
 MATING CYCLES: 500 CYCLES
 WIRE RANGE: $0.14mm^2 \sim 4mm^2$ (AWG26-AWG12)
 CONTACT TYPE: CRIMP CONTACT
- CONTACTS NEED TO BE ORDERED SEPARATELY.
 (ORDER No. REFER TO DRAWING: T20300X10XX000)

注释:

- 技术参数:
 绝缘材料: PC
 额定电压: 500V
 额定电流: 16A
 绝缘电阻: $\geq 400M\Omega$
 脉冲电压: 6KV
 污染等级: 3
 阻燃等级: UL94V-0
 插拔次数: 500次
 接线范围: $0.14mm^2 \sim 4mm^2$ (AWG26-AWG12)
 接线类型: 冷压接
- 端子需要单独订购。
 (订货号参考图面: T20300X10XX000)

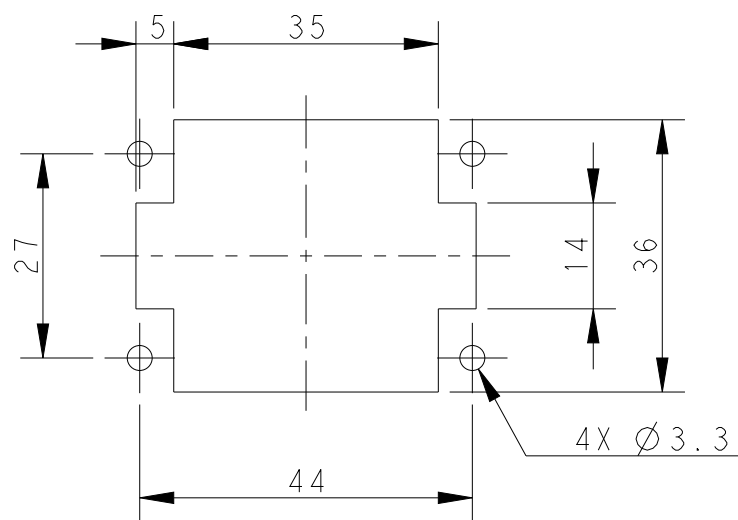
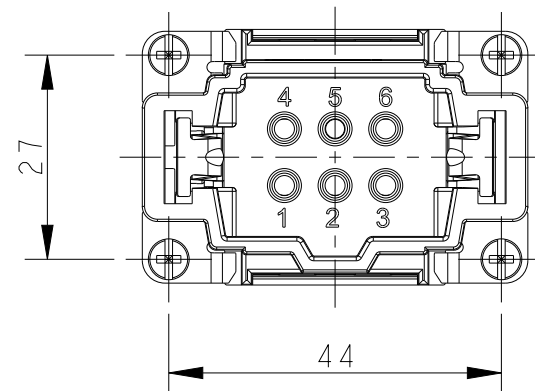

PANEL CUT FOR INSERTS FOR USING
 WITHOUT HOODS/ HOUSINGS
 不使用防护外壳时芯件的安装开孔图

THIS DRAWING IS A CONTROLLED DOCUMENT.		DWN	Gino.Yao	05APR2015	 TE Connectivity	NAME		HE-006-MC					
DIMENSIONS:		CHK	Chris.Wang	05APR2015		PRODUCT SPEC		108-137044					
mm		APVD	Xiang.Xu	05APR2015		APPLICATION SPEC		114-137044					
TOLERANCES UNLESS OTHERWISE SPECIFIED:						WEIGHT		-					
0 PLC ±-					Customer Drawing		SCALE	1:1	SHEET	1 OF 2	REV	C	
1 PLC ±-							SIZE	A3	CAGE CODE	00779	DRAWING NO		T2040064101000
2 PLC ±-							RESTRICTED TO		-				
3 PLC ±-													
4 PLC ±-													
ANGLES ±-													
FINISH													
-													
-													

THIS DRAWING IS UNPUBLISHED.

RELEASED FOR PUBLICATION

20

© COPYRIGHT 20 BY -

ALL RIGHTS RESERVED.

REVISIONS

P	LTR	DESCRIPTION	DATE	DWN	APVD
-		SEE SHEET 1	-	-	-

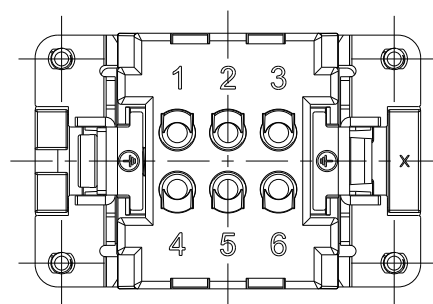

NOTE:
SEE SHEET 1
注释:
见页 1

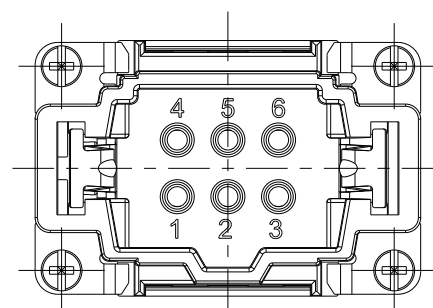
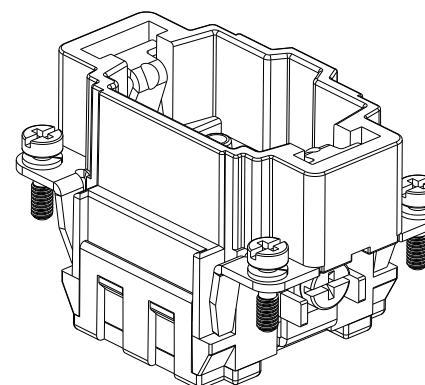
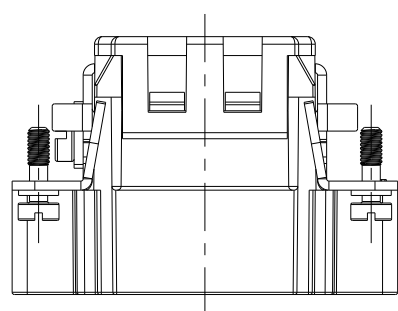
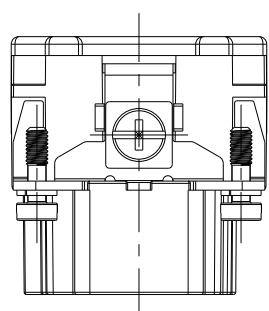

TYPE-2, T2040064101-001, STAINLESS STEEL SCREW, NO LOGO
类型-2, T2040064101-001, 不锈钢螺丝, 无LOGO

ALL SPEC DIMENSION REFER TO TYPE 1
所有产品规格尺寸参照 TYPE 1

T2040064101-001	HE-006-MC	HE-006 MALE INSERT, CRIMPING, STAINLESS STEEL SCREW, NO LOGO HE-006公插, 冷压针, 不锈钢螺丝, 无LOGO	TYPE-2 类型-2
T2040064101-000	HE-006-MC	HE-006 MALE INSERT, CRIMPING HE-006公插, 冷压针	TYPE-1 类型-1
PART NUMBER 料号	PART DESCRIPTION 描述		TYPE 类型

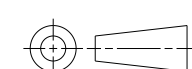
THIS DRAWING IS A CONTROLLED DOCUMENT.		DWN Gino.Yao 05APR2015	 TE Connectivity			
DIMENSIONS: mm		CHK Chris.Wang 05APR2015			NAME HE-006-MC	
TOLERANCES UNLESS OTHERWISE SPECIFIED:		APVD Xiang.Xu 05APR2015				
 0 PLC ±- 1 PLC ±- 2 PLC ±- 3 PLC ±- 4 PLC ±- ANGLES ±- FINISH		PRODUCT SPEC 108-137044	SIZE A300779	CAGE CODE C-T2040064101000	DRAWING NO	RESTRICTED TO
MATERIAL		WEIGHT	SCALE 1:1		SHEET 2 OF 2	REV C
		Customer Drawing				

单击下面可查看定价，库存，交付和生命周期等信息

[>>TE Connectivity\(泰科\)](#)