

REVISIONS						
P	F	ZONE	LTR	DESCRIPTION	DATE	APPROVED
		D		RELEASE OF NEW PRODUCT	02/93	J.L.M.
		A		REV PER ECN 0600-0670-93	01/94	N.G.F.
		B		REV PER ECN 0600-3774-95	04/95	JH

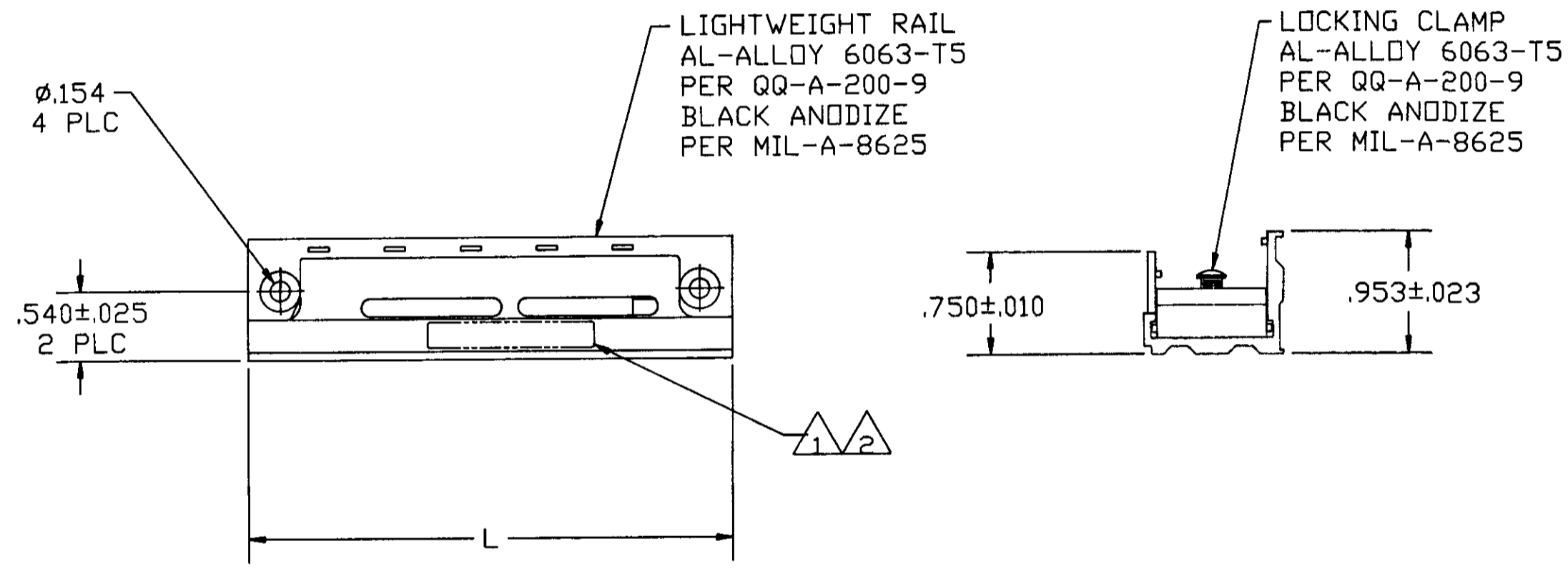
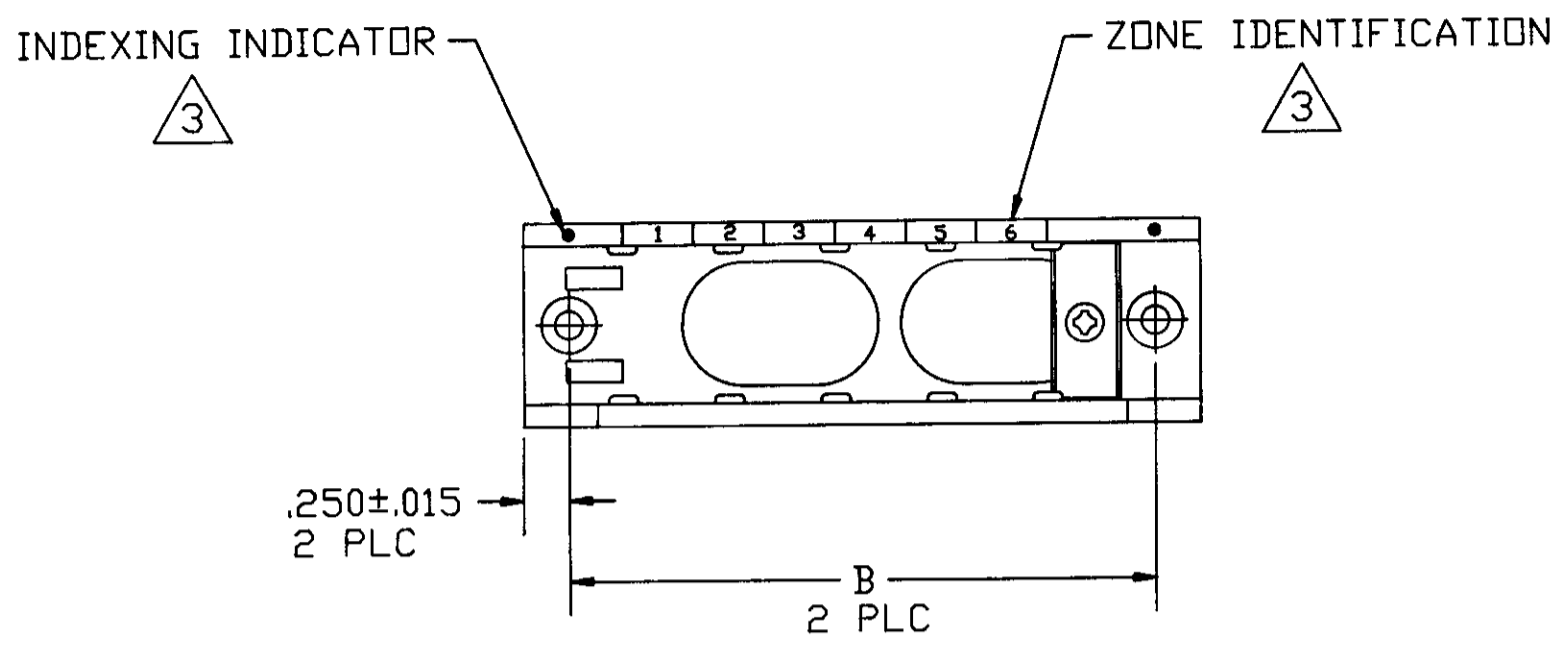

19	MRTBL-19	8.301	8.801	4-591621-9
1	MRTBL-1	1.281	1.781	4-591621-8
17	MRTBL-17	7.521	8.021	4-591621-7
13	MRTBL-13	5.961	6.461	4-591621-6
10	LS13179-L10	4.791	5.291	4-591621-3
11	LS13179-L11	5.181	5.681	4-591621-2
4	LS13179-L4	2.451	2.951	4-591621-1
20	MRTBL-20	8.691	9.191	4-591621-0
18	MRTBL-18	7.911	8.411	3-591621-8
16	MRTBL-16	7.131	7.631	3-591621-6
15	MRTBL-15	6.741	7.241	3-591621-5
14	MRTBL-14	6.351	6.851	3-591621-4
12	MRTBL-12	5.571	6.071	3-591621-2
10	MRTBL-10	4.791	5.291	3-591621-0
9	MRTBL-9	4.401	4.901	2-591621-9
8	MRTBL-8	4.011	4.511	2-591621-8
7	MRTBL-7	3.621	4.121	2-591621-7
6	MRTBL-6	3.231	3.731	2-591621-6
5	MRTBL-5	2.841	3.341	2-591621-5
4	MRTBL-4	2.451	2.951	2-591621-4
3	MRTBL-3	2.061	2.561	2-591621-3
2	MRTBL-2	1.671	2.171	2-591621-2
20		8.691	9.191	2-591621-0
19		8.301	8.801	1-591621-9
18		7.911	8.411	1-591621-8
17		7.521	8.021	1-591621-7
16		7.131	7.631	1-591621-6
15	M81714/16-13	6.741	7.241	1-591621-5
14	M81714/16-12	6.351	6.851	1-591621-4
13	M81714/16-11	5.961	6.461	1-591621-3
12	M81714/16-10	5.571	6.071	1-591621-2
11	M81714/16-9	5.181	5.681	1-591621-1
10	M81714/16-1	4.791	5.291	1-591621-0
9	M81714/16-8	4.401	4.901	591621-9
8	M81714/16-7	4.011	4.511	591621-8
7	M81714/16-6	3.621	4.121	591621-7
6	M81714/16-5	3.231	3.731	591621-6
5	M81714/16-4	2.841	3.341	591621-5
4	M81714/16-3	2.451	2.951	591621-4
3	M81714/16-2	2.061	2.561	591621-3
2		1.671	2.171	591621-2
1		1.281	1.781	591621-1

- 3 MARK RAIL ASSEMBLY WITH INDEXING INDICATOR AND ZONE IDENTIFICATION AT APPROXIMATE AREA SHOWN.
- 2 MARK MILITARY PART NO., CUSTOMER PART NO. IF REQUIRED .060 MINIMUM HIGH CHARACTERS AT AREA SHOWN.
- 1 MARK "AMP", AMP PART NO. AND DATE CODE .060 MINIMUM HIGH CHARACTERS AT AREA SHOWN.

DO NOT SCALE PRINT. UNLESS OTHERWISE SPECIFIED DIMENSIONS ARE IN INCHES. TOLERANCES ON: 2 PLC DEC ± -- 3 PLC DEC ± .005 ANGLES ± ---	CONTRACT NO		AMP INCORPORATED Harrisburg, Pa. 17105			
	DR	J. MECK 02-25-93				
	CHK	R. RYAN 02-26-93				
	APPD	R. RYAN 02-26-93				
MATERIAL	APPD	D. ENGLER 02-26-93	NAME LIGHTWEIGHT RAIL FEED-BACK ASSEMBLY TJ			
FINISH	DSGN APPD	OTHER APPD				
MODULE CAPACITY		MARKING 2	DIM. B	DIM. L ±.015	PART NO	
SIZE		C	FSCM NO	00779	DRAWING NO	591621
SCALE		1 : 1	SHEET		1 OF 1	

THIS DRAWING IS A CONTROLLED DOCUMENT FOR AMP INCORPORATED. IT IS SUBJECT TO CHANGE AND THE CONTROLLING ENGINEERING ORGANIZATION SHOULD BE CONTACTED FOR THE LATEST REVISION.

单击下面可查看定价，库存，交付和生命周期等信息

[>>TE Connectivity\(泰科\)](#)