

THIS DRAWING IS UNPUBLISHED. RELEASED FOR PUBLICATION 20
 © COPYRIGHT 20 BY - ALL RIGHTS RESERVED.

PROPERTY OF THE TE CONNECTIVITY
 THIS INFORMATION IS CONFIDENTIAL AND PROPERTY TO TYCO ELECTRONICS CORPORATION
 AND ITS WORLDWIDE SUBSIDIARIES AND AFFILIATES (TE). IT MAY NOT BE DISCLOSED TO
 ANYONE, OTHER THAN TE PERSONNEL, WITHOUT AUTHORIZATION FROM TE (www.TE.com).

LOC		DIST		REVISIONS			
P	LTR	DESCRIPTION	DATE	DWN	APVD		
A		NEW RELEASE PER ECO-16-000996	160122				
B		REVISION PER ECO-18-018558	20NOV2018	JPF	JPF		

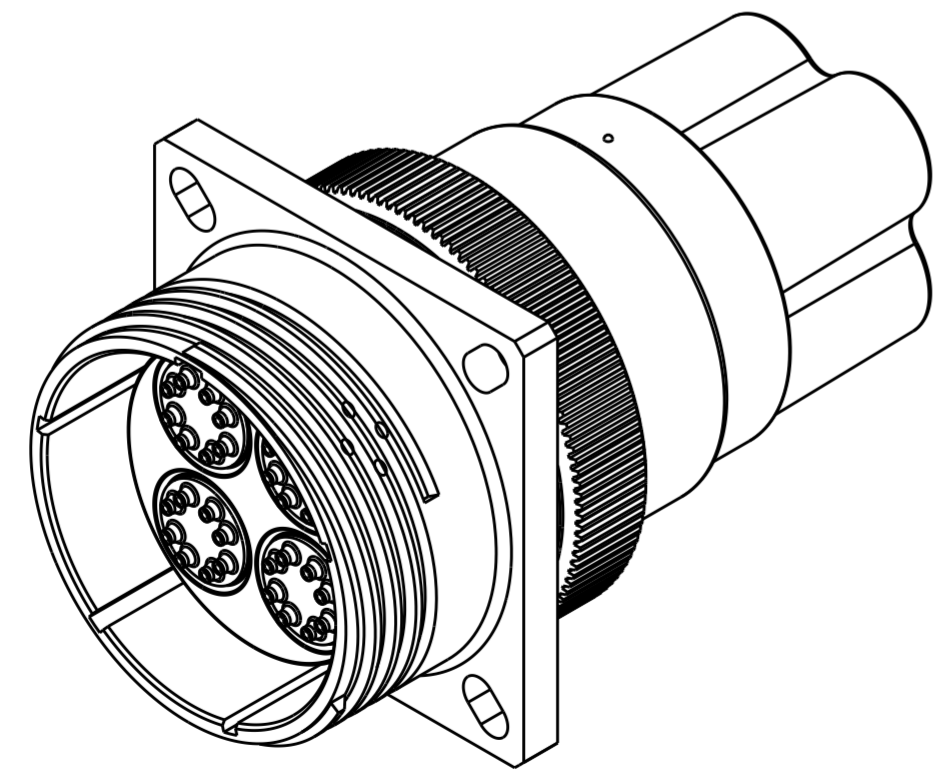
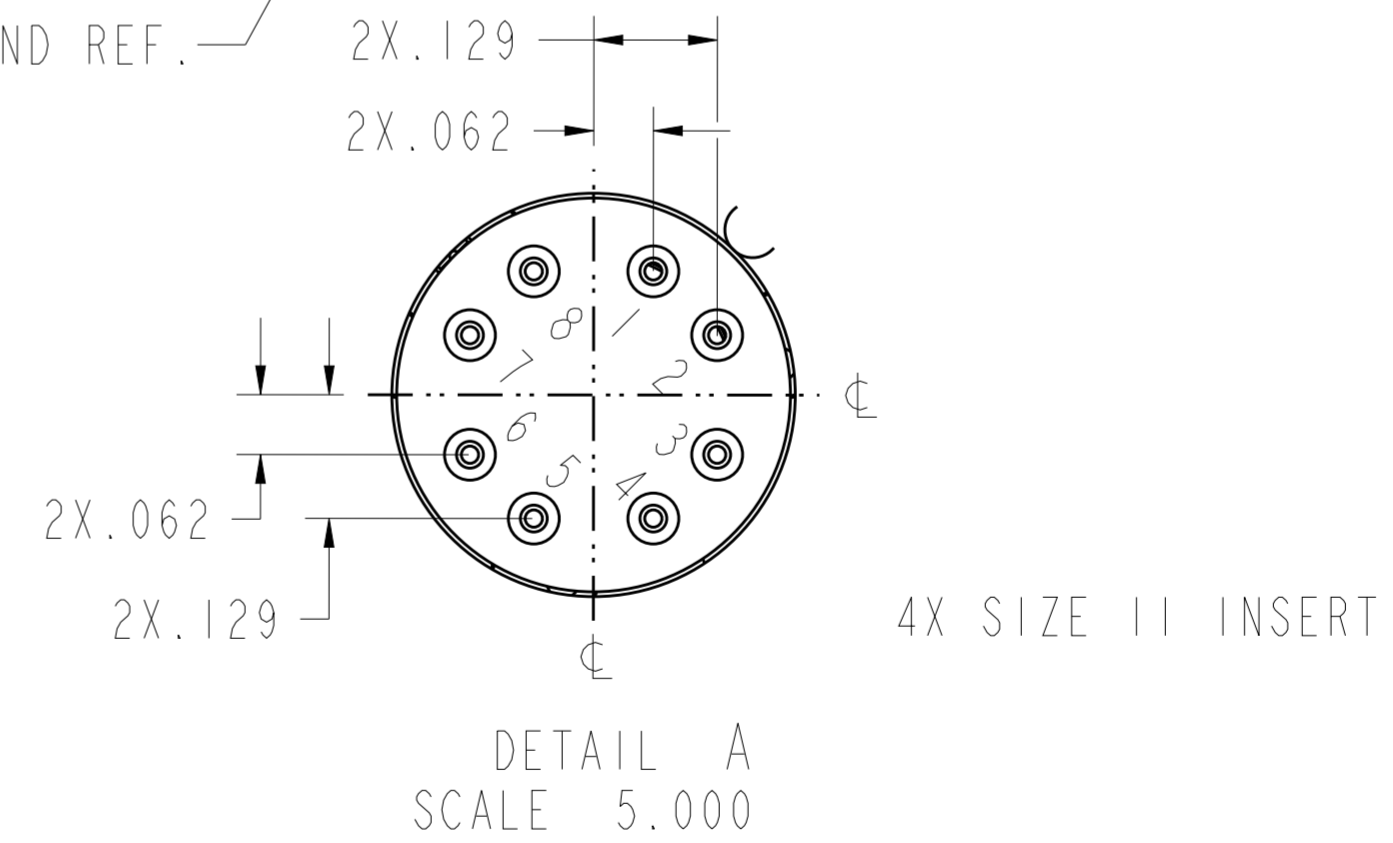
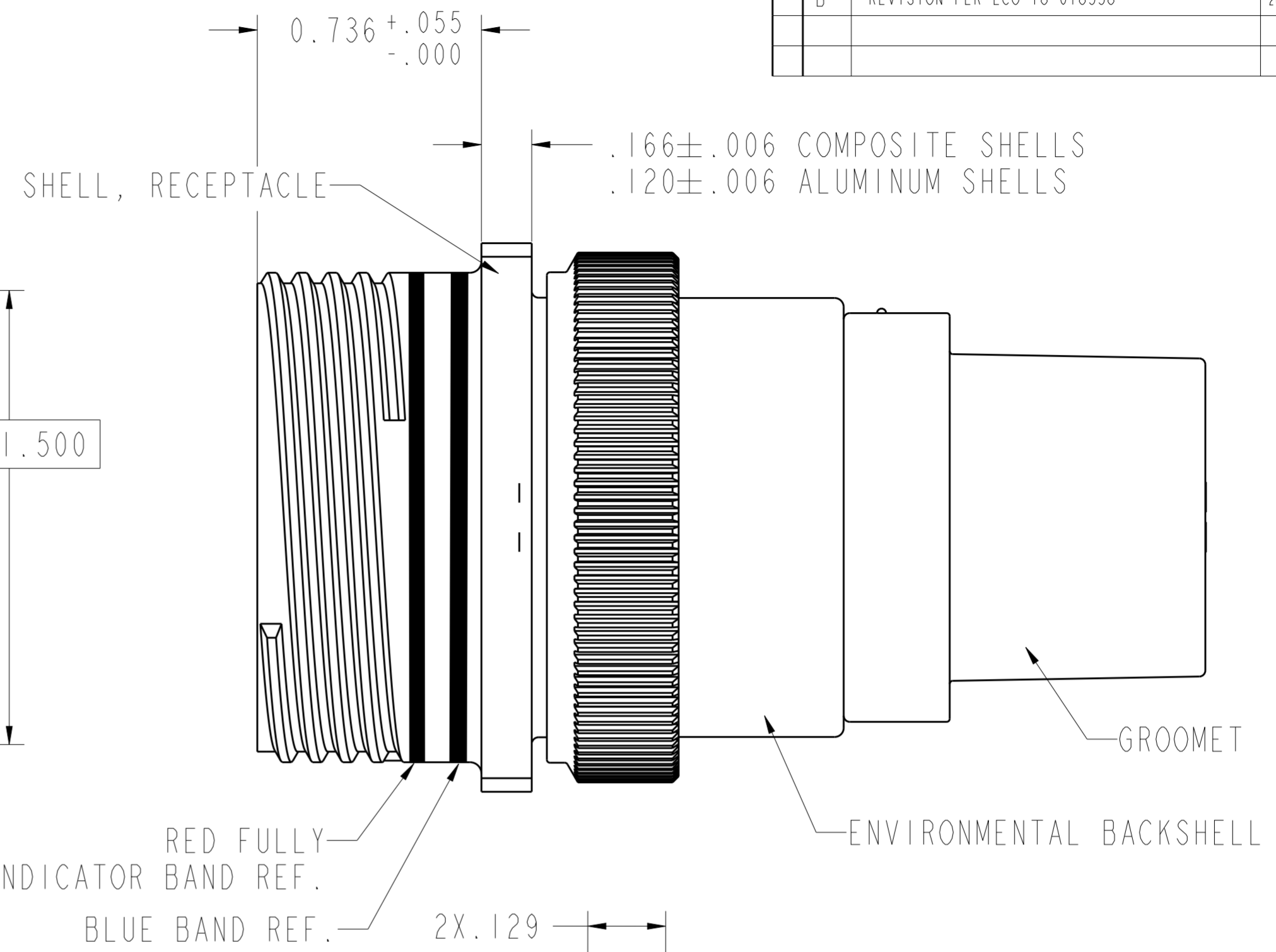
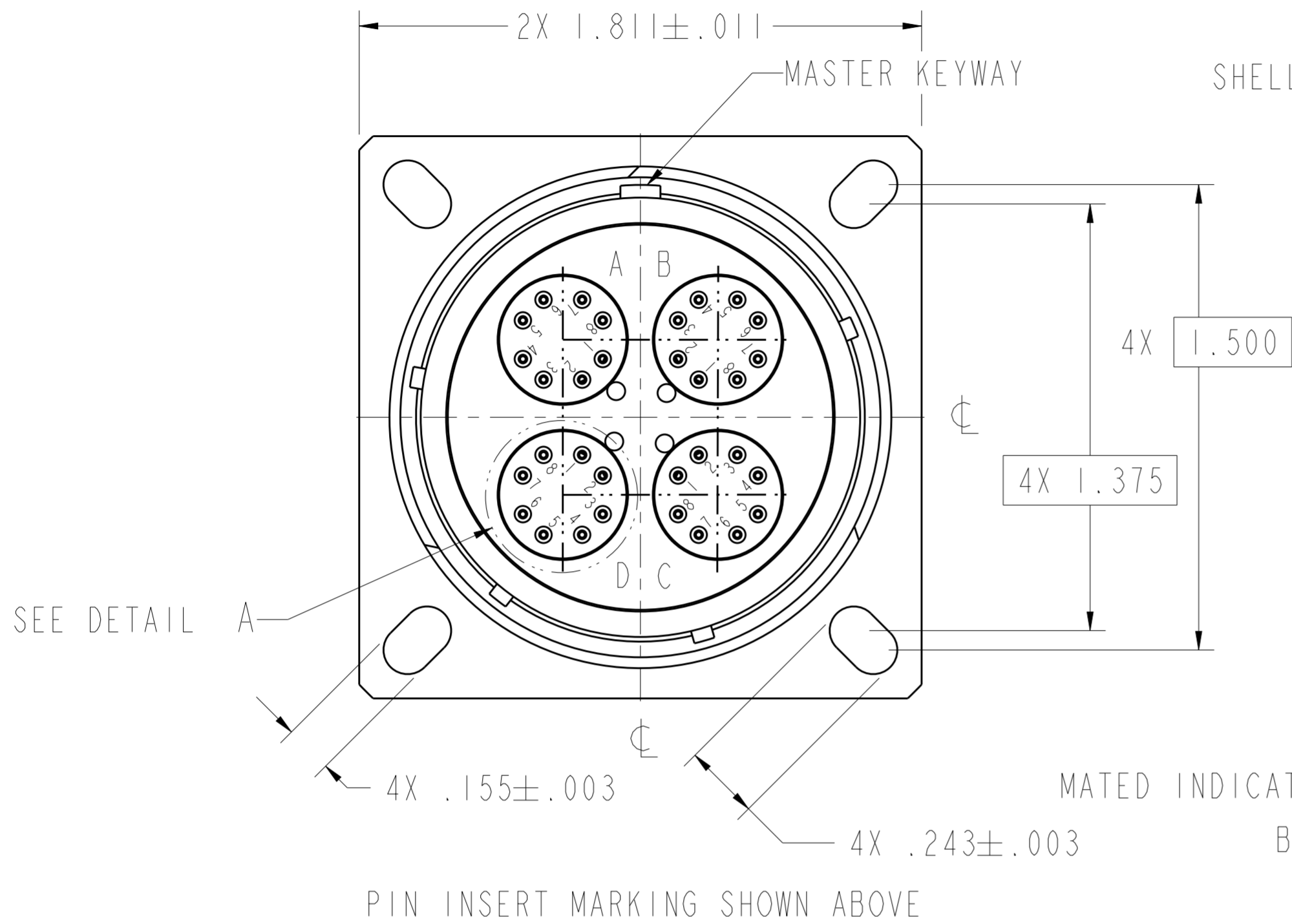

SEE SHEET 2 FOR APPLICABLE NOTES

THIS DRAWING IS A CONTROLLED DOCUMENT.		DWN	JPF	140218	 TE Connectivity														
DIMENSIONS:		CHK	JPF	160122															
i n		APVD	AR	160122															
<table border="1"> <tr><td>0 PLC</td><td>±</td></tr> <tr><td>1 PLC</td><td>±0.1</td></tr> <tr><td>2 PLC</td><td>±0.01</td></tr> <tr><td>3 PLC</td><td>±0.001</td></tr> <tr><td>4 PLC</td><td>±0.0001</td></tr> <tr><td>ANGLES</td><td>±</td></tr> <tr><td>FINISH</td><td>±</td></tr> </table>		0 PLC	±	1 PLC		±0.1	2 PLC	±0.01	3 PLC	±0.001	4 PLC	±0.0001	ANGLES	±	FINISH	±	PRODUCT SPEC	NAME	
0 PLC	±																		
1 PLC	±0.1																		
2 PLC	±0.01																		
3 PLC	±0.001																		
4 PLC	±0.0001																		
ANGLES	±																		
FINISH	±																		
MATERIAL	3 TBD	4	APPLICATION SPEC		SIZE	CAGE CODE	DRAWING NO	RESTRICTED TO											
CUSTOMER DRAWING		WEIGHT	-		A2	00779	C-CFX20x2532xxx	-											
SCALE		2.500		SHEET		1 OF 6		REV B											

THIS DRAWING IS UNPUBLISHED. RELEASED FOR PUBLICATION 20
 © COPYRIGHT 20 BY - ALL RIGHTS RESERVED.

PROPERTY OF THE TE CONNECTIVITY
 THIS INFORMATION IS CONFIDENTIAL AND PROPERTY TO TYCO ELECTRONICS CORPORATION
 AND ITS WORLDWIDE SUBSIDIARIES AND AFFILIATES (TE). IT MAY NOT BE DISCLOSED TO
 ANYONE, OTHER THAN TE PERSONNEL, WITHOUT AUTHORIZATION FROM TE (www.TE.com).

LOC		DIST		REVISIONS			
P	LTR	DESCRIPTION	DATE	DWN	APVD		
-	-	SEE SHEET 1	-	-	-		

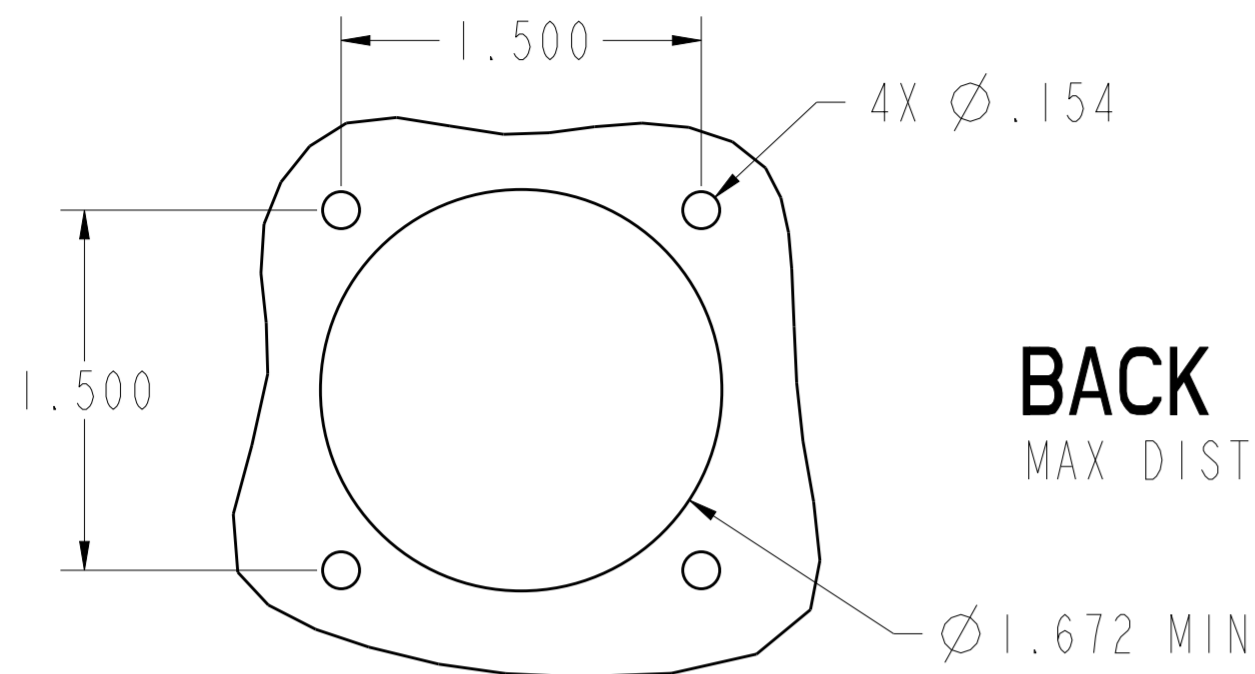

BACK PANEL MOUNTING

MAX DISTANCE BETWEEN MOUNTING SCREWS

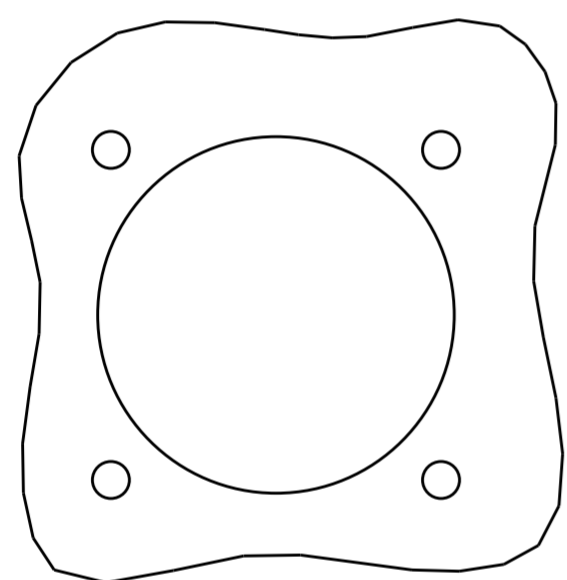

FRONT PANEL MOUNTING

MAX DISTANCE BETWEEN MOUNTING SCREWS

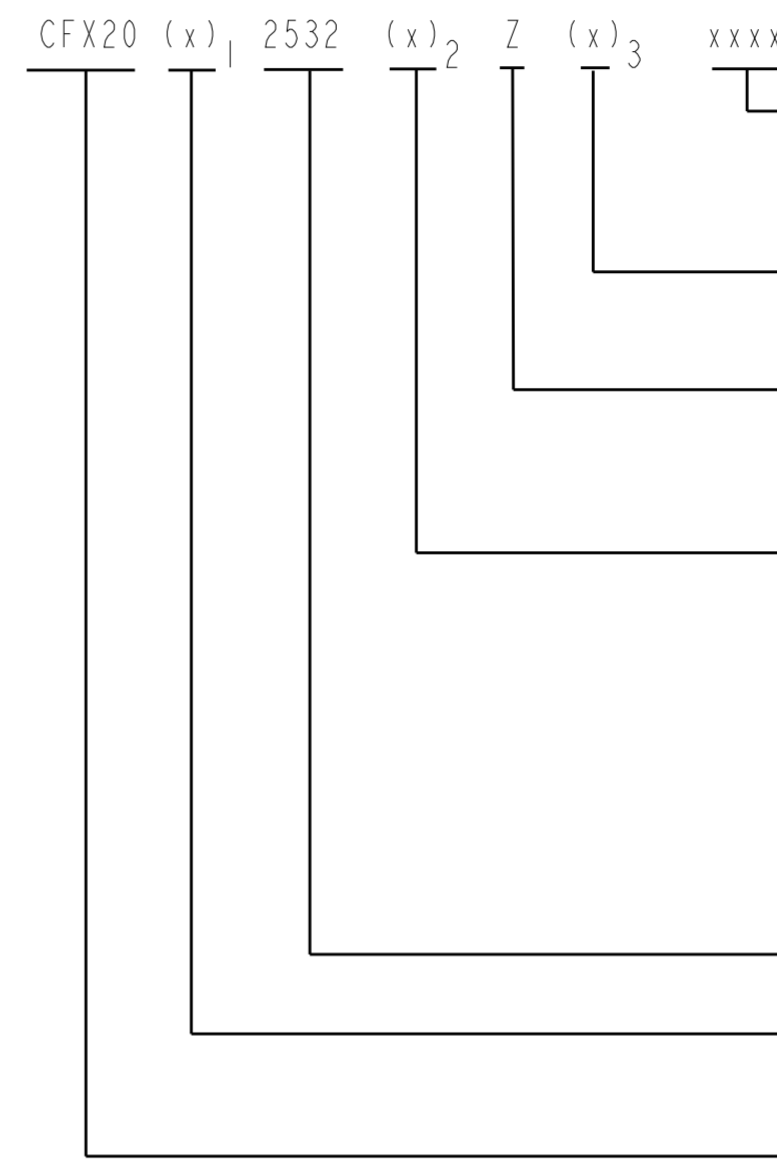

MODIFICATION
 M002 = INCLUDE QTY 4 BAND CLAMPS
 PART NUMBER BND-0812S

KEYING POSITION:
 N, A, B, C, D, E

CONTACT TERMINATION:
 Z = CRIMPED CONTACT
 A THROUGH Y = EXTENDED CONTACT

CONTACT FINISH:
 P = PIN LOCALIZED GOLD FINISH
 S = SOCKET LOCALIZED GOLD FINISH
 F = PIN FULL GOLD FINISH
 G = SOCKET FULL GOLD FINISH
 H = PIN HI REL FINISH
 J = SOCKET HI REL FINISH
 A = LESS PIN CONTACT
 B = LESS SOCKET CONTACT

SHELL SIZE/INSERT ARRANGMENT

PLATING/SHELL MATERIAL:
 SEE TABLE

BASIC IDENTIFIER

- 7. TORQUE LEVEL FOR SIZE 25 BACKSHELL: 140/120 INCH*POUNDS.
- 6. COMPOSITE WEIGHT WITHOUT MODULES AND CABLE: 0.196 POUNDS.
 METAL WEIGHT WITHOUT MODULES AND CABLE: 0.227 POUNDS.
 PIN MODULE, FOLLOWER AND BRAID SUPPORTS WEIGHT: .011 LBS.
 SOCKET MODULE, FOLLOWER AND BRAID SUPPORTS WEIGHT: .017 LBS.

5. MATES WITH CFX26x2532xxx.

4. FINISH: SHELL/BACKSHELL - SEE TABLE.
 CONTACTS - SEE PART NUMBER BREAKDOWN.

3. MATERIAL: SHELL - SEE TABLE.
 BACKSHELL/ COUPLING RING - ALUMINUM ALLOY.
 CONTACTS - COPPER ALLOY.
 RESILIENT INSERTS/BACKSHELL GROMMET - SILICONE ELASTOMER.
 PLASTIC INSERTS - THERMOPLASTIC.

2. FOR AVAILABILITY CONSULT FACTORY.

1. ALL DIMENSIONS ARE IN INCHES UNLESS OTHERWISE SPECIFIED.

PART NUMBER (x) ₁	PLATING	SHELL MATERIAL
M	NICKEL	COMPOSITE
J	O.D. CAD	COMPOSITE
F	NICKEL	ALUMINUM
W	O.D. CAD	ALUMINUM
S	NICKEL	STAINLESS STEEL
T	PTFE NICKEL	ALUMINUM
Z	BLACK ZINC NICKEL	ALUMINUM

SIZE 25 PART NUMBER(x) ₃	POS
CFX20x2532xZN	N
CFX20x2532xZA	A
CFX20x2532xZB	B
CFX20x2532xZC	C
CFX20x2532xZD	D
CFX20x2532xZE	E

THIS DRAWING IS A CONTROLLED DOCUMENT.

DWN	JPF	140218
CHK	JPF	160122
APVD	AR	160122

STE TE Connectivity

NAME: CONNECTOR, RECEPTACLE
 FLANGE MOUNT
 2532 ARRANGEMENT

SIZE	A2	CAGE CODE	00779	DRAWING NO	CFX20x2532xxx	RESTRICTED TO	-
WEIGHT	-	SCALE	2.500	SHEET	2	OF	6
CUSTOMER DRAWING		REV	B				

THIS DRAWING IS UNPUBLISHED. RELEASED FOR PUBLICATION 20
 © COPYRIGHT 20 BY - ALL RIGHTS RESERVED.

LOC		DIST		REVISIONS			
P	LTR	DESCRIPTION	DATE	DWN	APVD		
-	-	SEE SHEET 1	-	-	-		

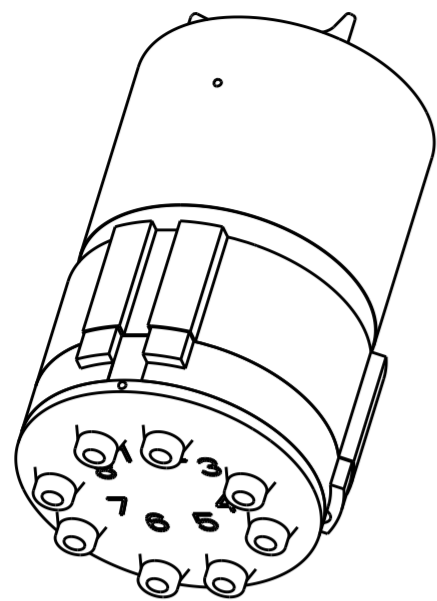

PIN MODULES	
PART NUMBER	DESCRIPTION
A-08P-02	PIN MODULE A
B-08P-02	PIN MODULE B
C-08P-02	PIN MODULE C
D-08P-02	PIN MODULE D

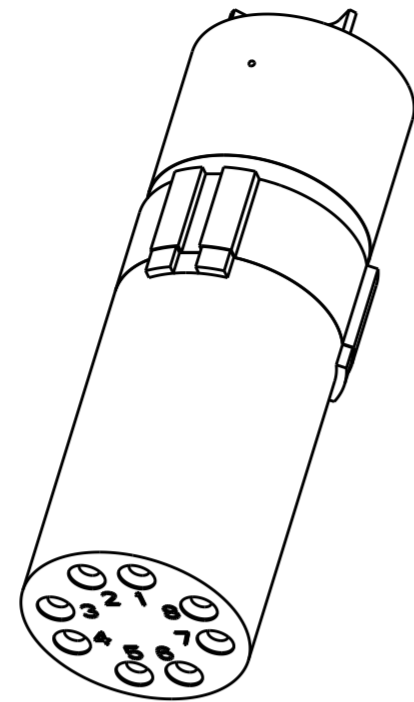

SOCKET MODULES	
PART NUMBER	DESCRIPTION
A-08S-02	SKT MODULE A
B-08S-02	SKT MODULE B
C-08S-02	SKT MODULE C
D-08S-02	SKT MODULE D

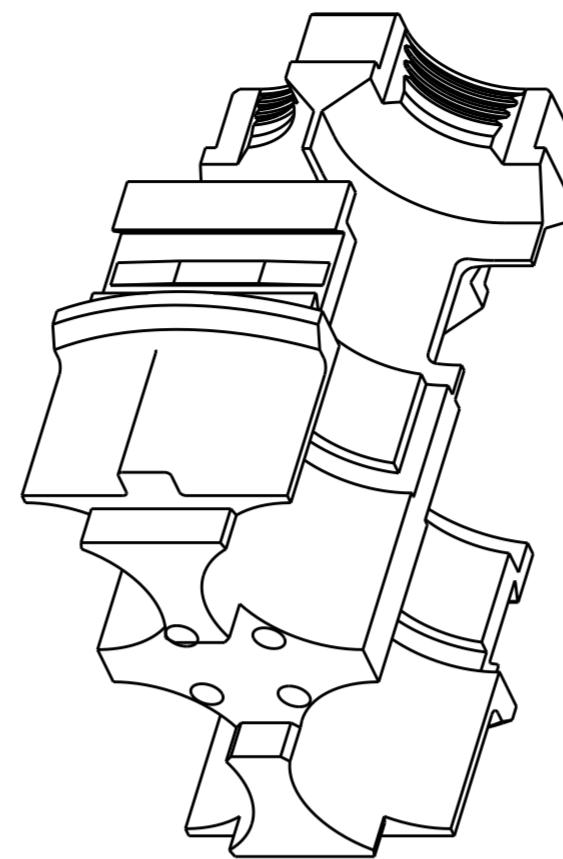

MODULE HOUSING	
PART NUMBER	DESCRIPTION
3311-253-25266	MODULE HOUSING

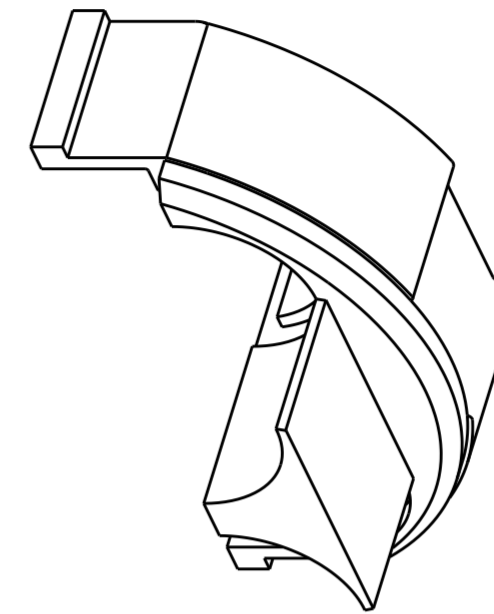

MODULE RETAINER	
PART NUMBER	DESCRIPTION
3311-254-25266	MODULE RETAINER

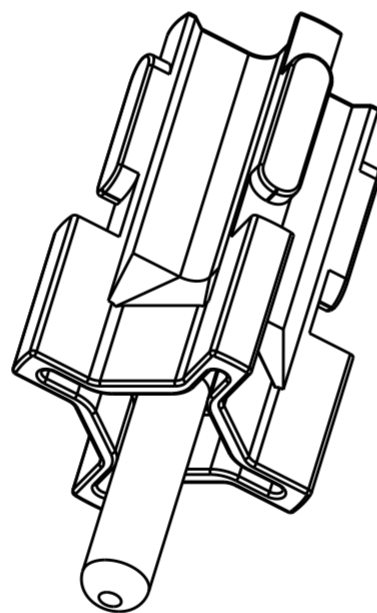

MODULE FOLLOWER	
PART NUMBER	DESCRIPTION
3302-210-08266	MODULE FOLLOWER

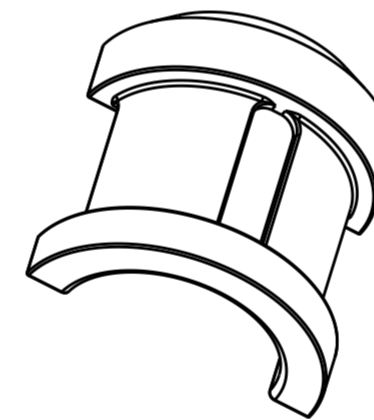

BRAID SUPPORT	
PART NUMBER	DESCRIPTION
3320-215-00261	BRAID SUPPORT

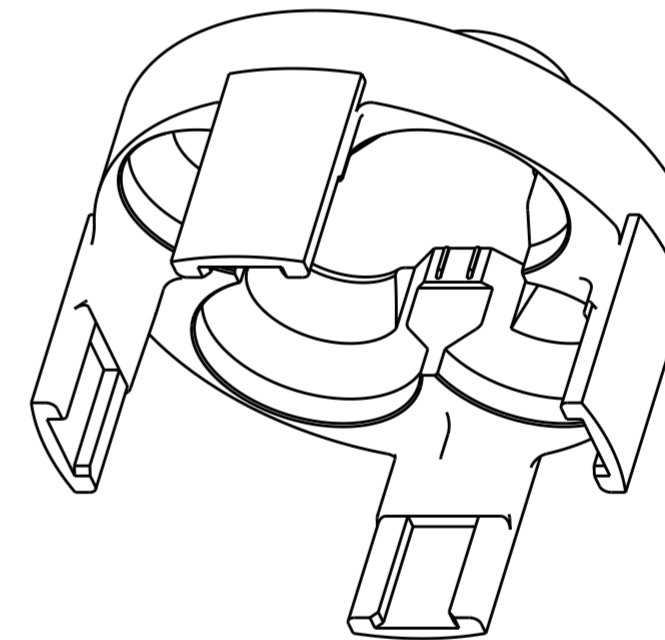

BRAID FOLLOWER	
PART NUMBER	DESCRIPTION
3311-251-25266	BRAID FOLLOWER

THIS DRAWING IS A CONTROLLED DOCUMENT.		DWN	JPF	140218	TE Connectivity
		CHK	JPF	160122	
		APVD	AR	160122	
DIMENSIONS: in 		TOLERANCES UNLESS OTHERWISE SPECIFIED: 0 PLC ±- 1 PLC ±0.1 2 PLC ±0.01 3 PLC ±0.001 4 PLC ±0.0001 ANGLES ± FINISH		NAME CONNECTOR, RECEPTACLE FLANGE MOUNT 2532 ARRANGEMENT	
MATERIAL TBD		PRODUCT SPEC -		SIZE A2	
		APPLICATION SPEC -		CAGE CODE 00779	
		WEIGHT -		DRAWING NO C-CFX20x2532xxx	
		CUSTOMER DRAWING		RESTRICTED TO -	
		SCALE 2.500		SHEET 3 OF 6 REV B	

THIS DRAWING IS UNPUBLISHED. RELEASED FOR PUBLICATION 20
 © COPYRIGHT 20 BY - ALL RIGHTS RESERVED.

LOC		DIST		REVISIONS			
P	LTR	DESCRIPTION	DATE	DWN	APVD		
-	-	SEE SHEET 1	-	-	-		

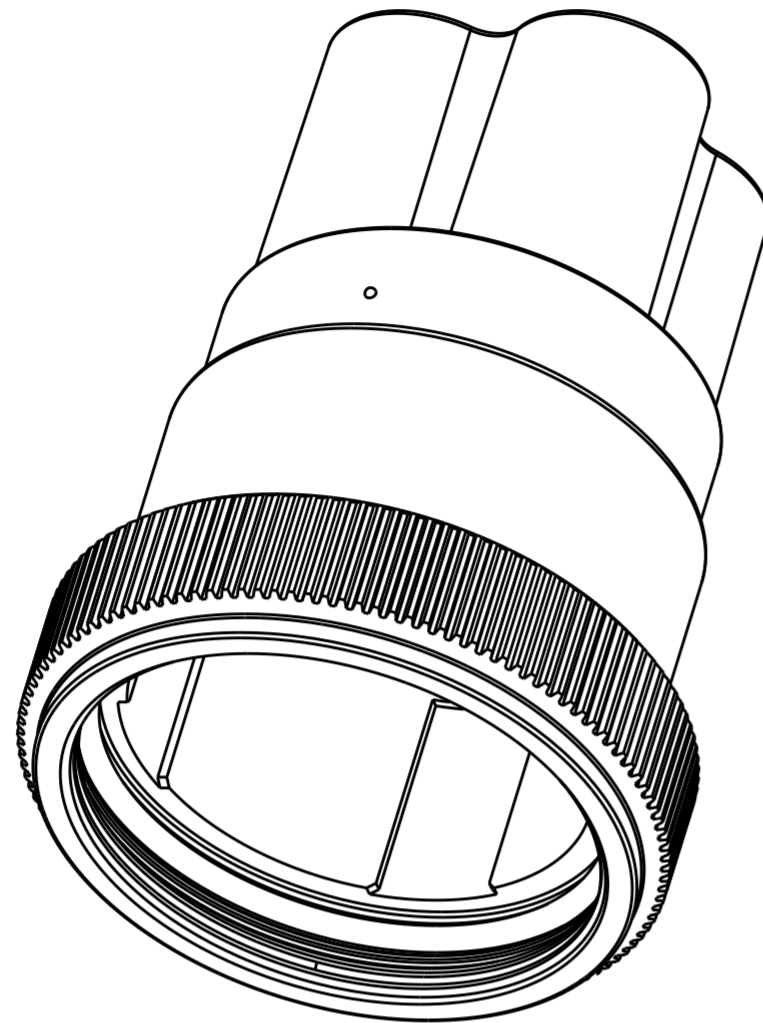

RECEPTACLE BACKSHELL	
PART NUMBER	TYPE DESCRIPTION
3308-210-2558	NICKEL PLATED ALUMINUM
3308-210-25149	OD CAD PLATED ALUMINUM
3308-210-25336	NICKEL FLUOROCARBON POLYMER PLATED ALUMINUM
3308-210-25332	BLACK ZINC NICKEL PLATED ALUMINUM

P,S LOCALIZED FINISHED CONTACTS	
PART NUMBER	DESCRIPTION
38941-22L	PIN CONTACT
38943-22L	SOCKET CONTACT

F,G FULL GOLD FINISHED CONTACTS	
PART NUMBER	DESCRIPTION
38941-22	PIN CONTACT
38943-22	SOCKET CONTACT

H,J HI REL FINISHED CONTACTS	
PART NUMBER	DESCRIPTION
12331-22	PIN CONTACT
12333-22	SOCKET CONTACT

INSERTION/REMOVAL TOOL	
PART NUMBER	DESCRIPTION
M81969/14-01	SIZE 22 TOOL

BAND CLAMP	
PART NUMBER	DESCRIPTION
BND-0812S	ONE STEP BAND - STRAIGHT

THIS DRAWING IS A CONTROLLED DOCUMENT.		DWN JPF 140218	STE TE Connectivity	
DIMENSIONS: in		CHK JPF 160122		
TOLERANCES UNLESS OTHERWISE SPECIFIED:		APVD AR 160122	NAME CONNECTOR, RECEPTACLE FLANGE MOUNT 2532 ARRANGEMENT	
0 PLC ± 1 PLC ±0.1 2 PLC ±0.01 3 PLC ±0.001 4 PLC ±0.0001 ANGLES ± FINISH		PRODUCT SPEC -	SIZE A2	
MATERIAL TBD		APPLICATION SPEC -	CAGE CODE 00779	DRAWING NO CFX20x2532xxx
		WEIGHT -	RESTRICTED TO -	
		CUSTOMER DRAWING	SCALE 2.500	SHEET 4 OF 6 REV B

THIS DRAWING IS UNPUBLISHED. RELEASED FOR PUBLICATION 20
 © COPYRIGHT 20 BY - ALL RIGHTS RESERVED.

LOC		DIST		REVISIONS			
P	LTR	DATE	DWN	APVD			
-	-	-	-	-	SEE SHEET 1		

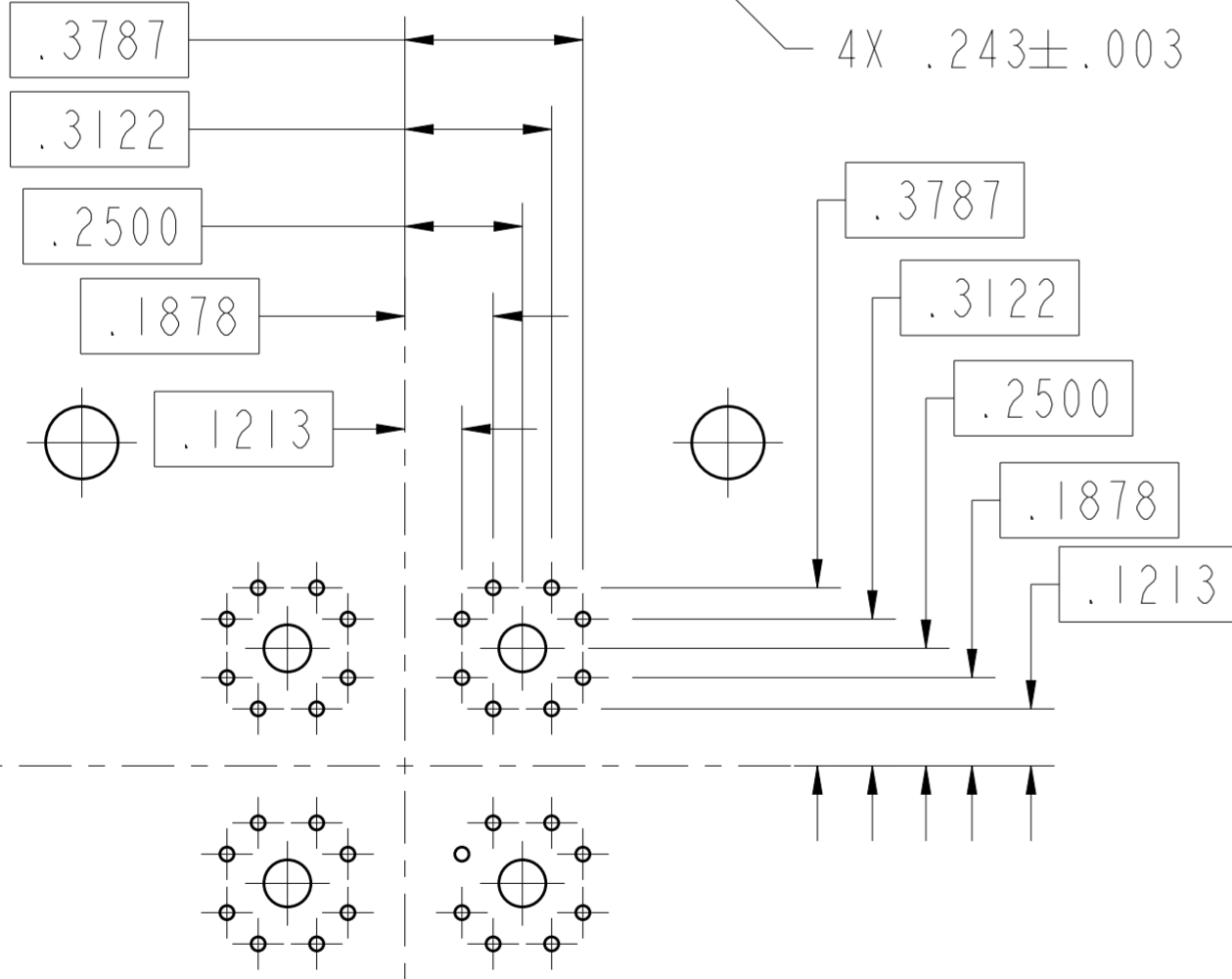
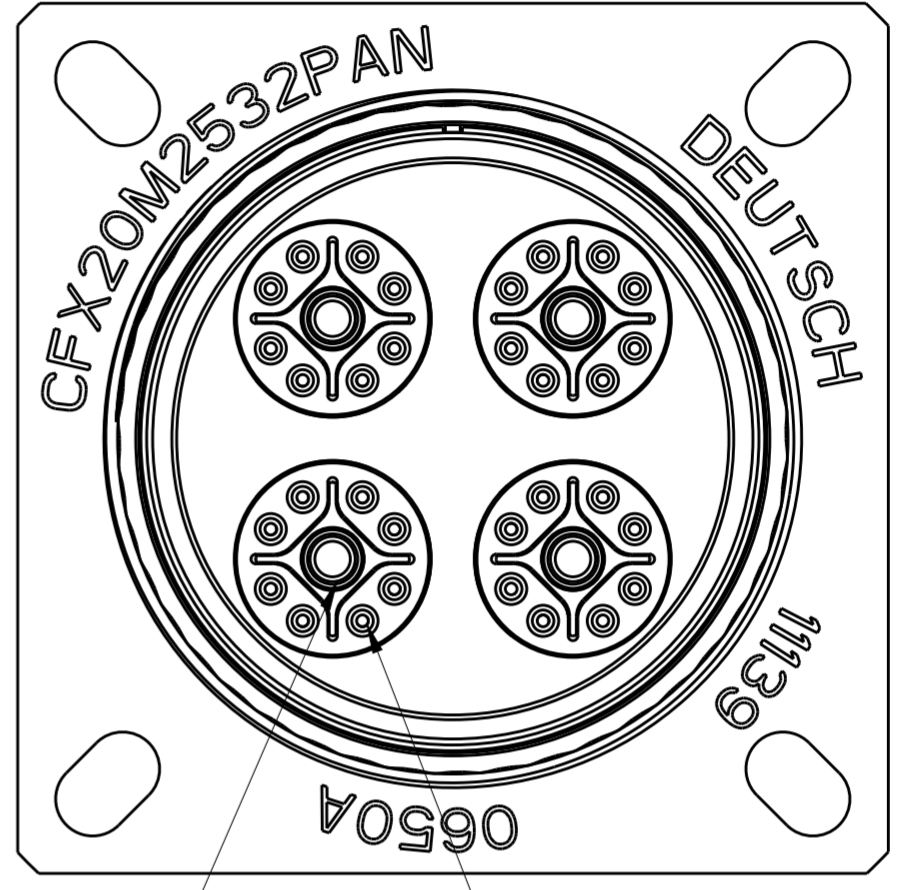
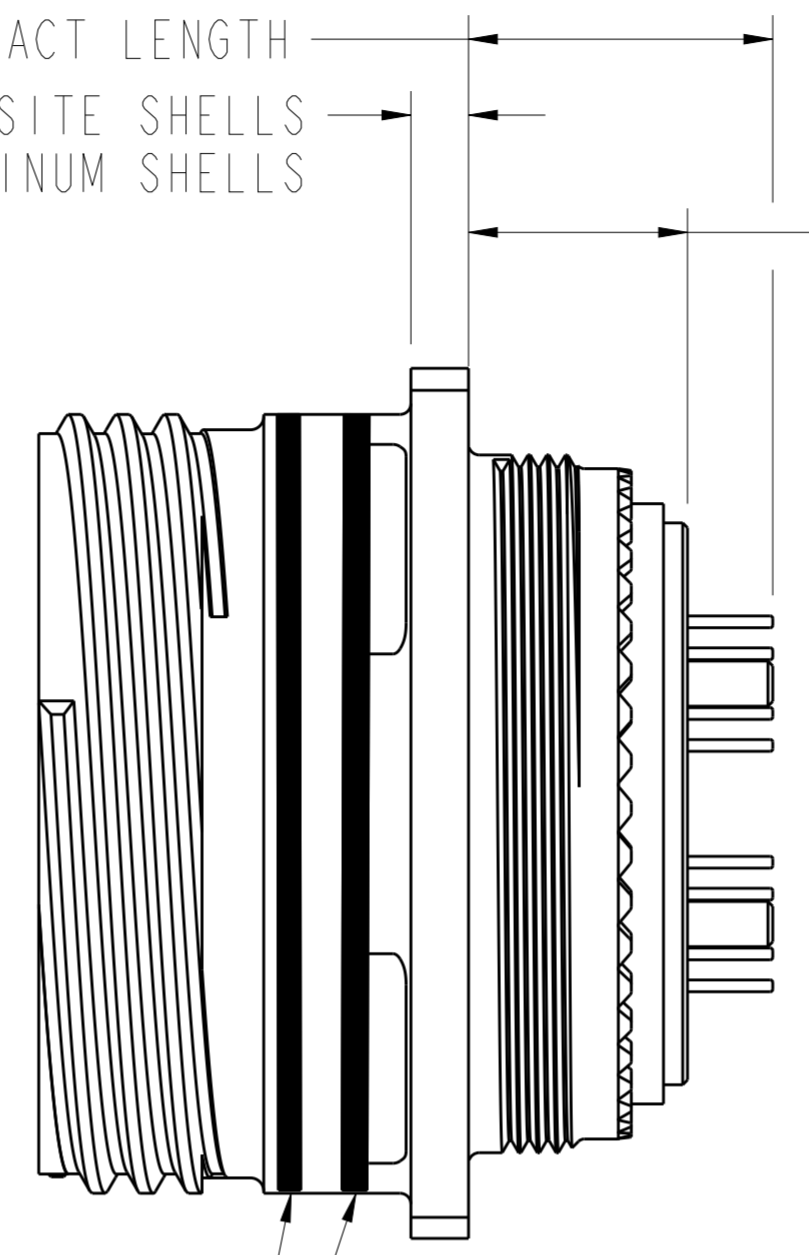
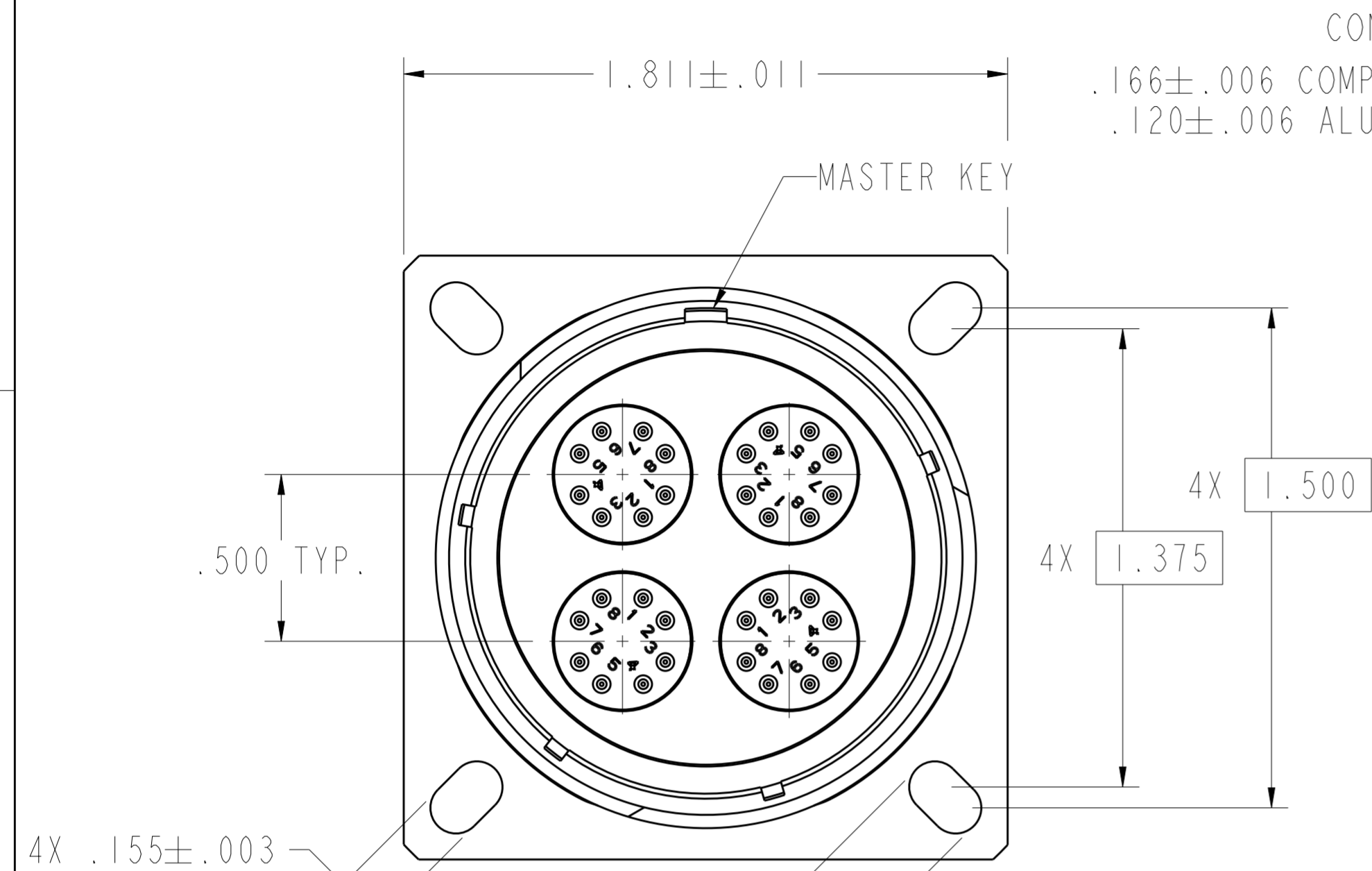

CONTACT CONFIGURATION IDENTIFIER	CONTACT LENGTH ±.025	CONTACT ONE DIAMETER ±.003	CONTACT TWO DIAMETER ±.003	PLATING
A	.634 ALUMINUM SHELLS .623 COMPOSITE SHELLS	.025	.095	GOLD OVER NICKEL
B	TBD			
C	TBD			
D	TBD			

NOTES:
 1. THIS PAGE IS FOR CONTACT TERMINATION CODE A THROUGH Y.
 SEE PAGE 2 FOR PART NUMBER BREAKDOWN.

THIS DRAWING IS A CONTROLLED DOCUMENT.

DWN	JPF	140218
CHK	JPF	160122
APVD	AR	160122

STE TE Connectivity

NAME: CONNECTOR, RECEPTACLE
 FLANGE MOUNT
 2532 ARRANGEMENT

SIZE	A2	CAGE CODE	00779	DRAWING NO	C-CFX20x2532xxx	RESTRICTED TO	-
WEIGHT	-	CUSTOMER DRAWING	SCALE	2.500	SHEET	5	OF 6
						REV	B

THIS DRAWING IS UNPUBLISHED. RELEASED FOR PUBLICATION 20
 © COPYRIGHT 20 BY - ALL RIGHTS RESERVED.

CONTACT LENGTH

REVISIONS							
LOC	DIST	P	LTR	DESCRIPTION	DATE	DWN	APVD
-	-	-	-	SEE SHEET 1	-	-	-

11H8 SOCKET ARRANGEMENT

11H8 SOCKET ARRANGMENT

.166±.006 COMPOSITE SHELLS
 .120±.006 ALUMINUM SHELLS
 .456±.010 ALUMINUM SHELLS
 .445±.010 COMPOSITE SHELLS

.177±.015

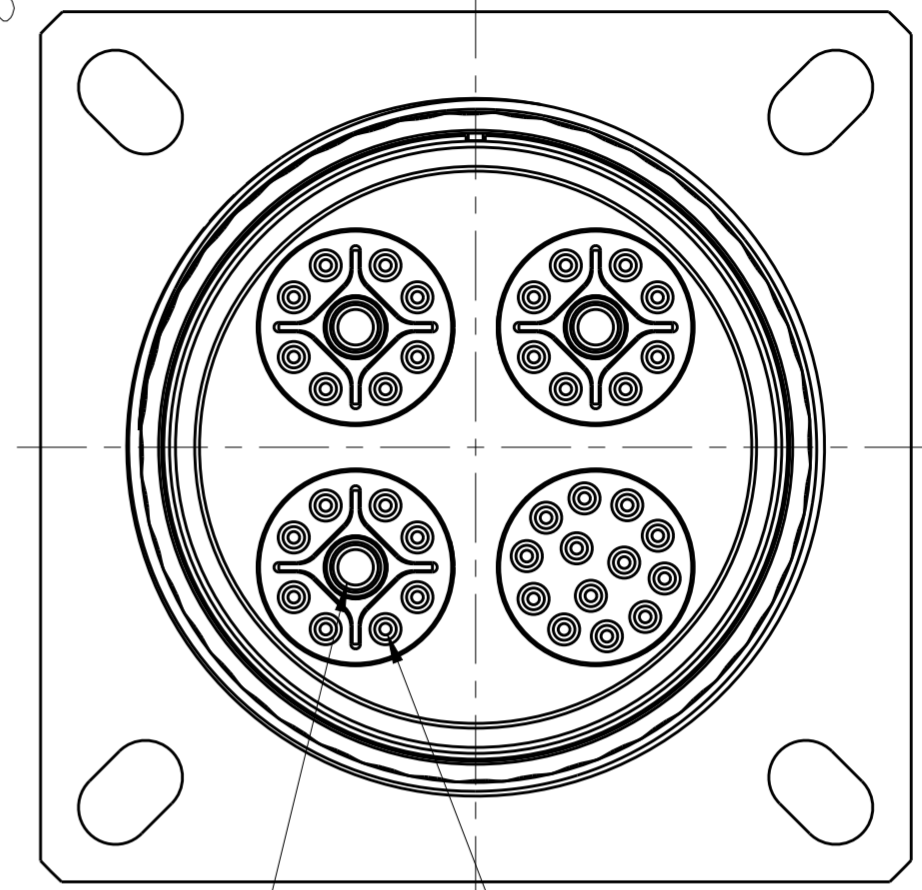
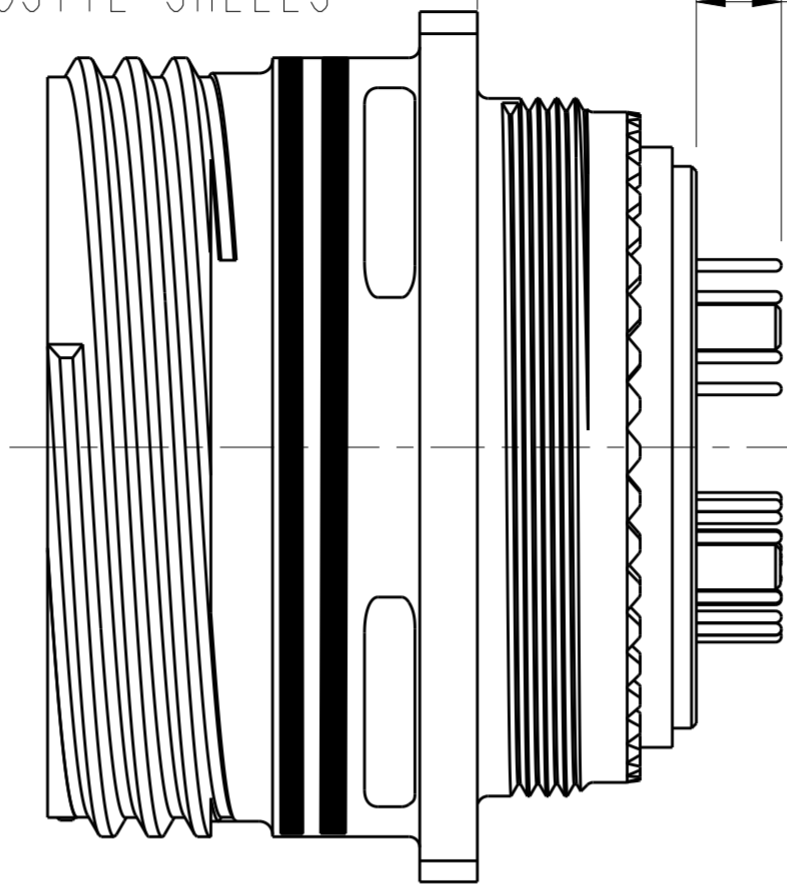
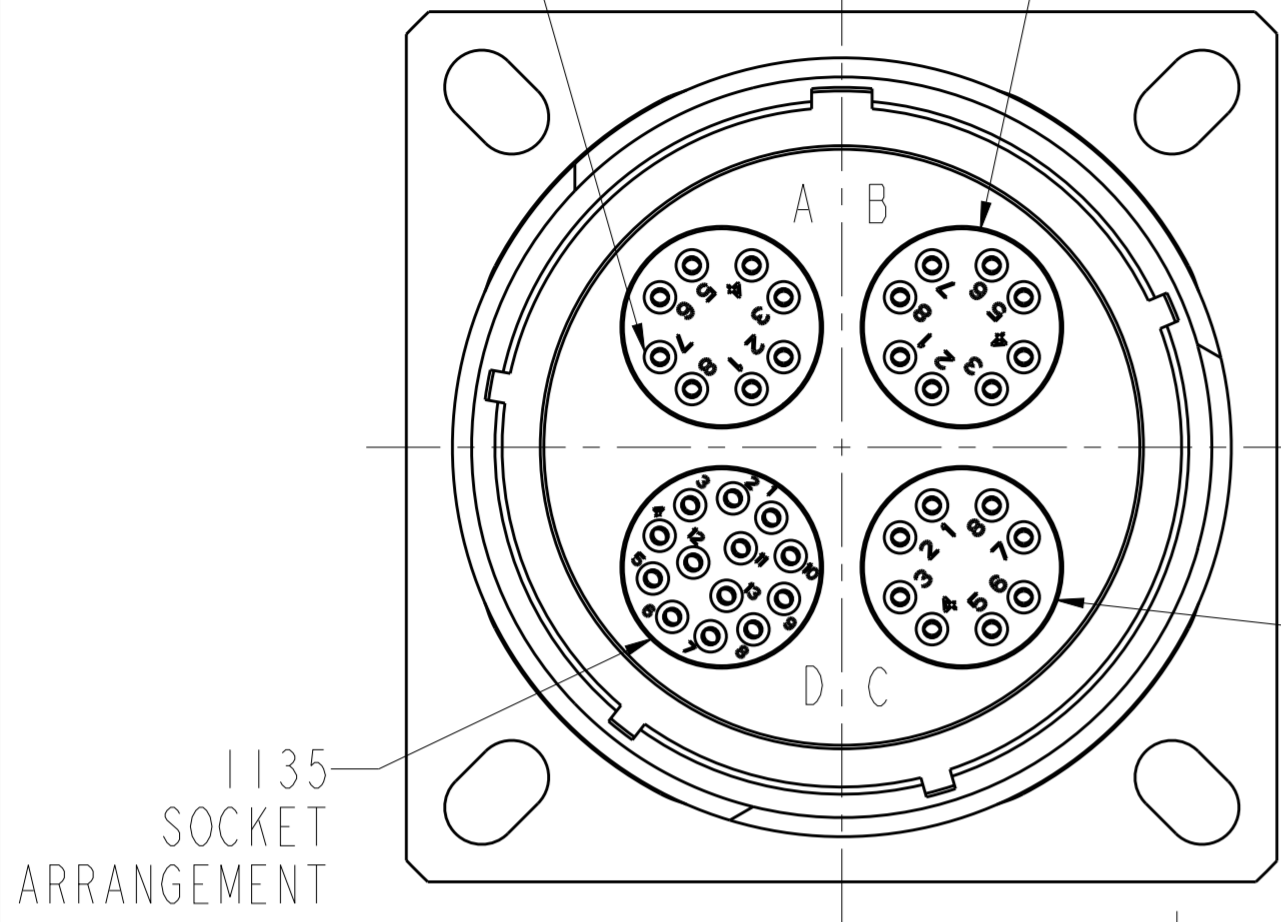

4X CONTACT TWO

32X CONTACT ONE

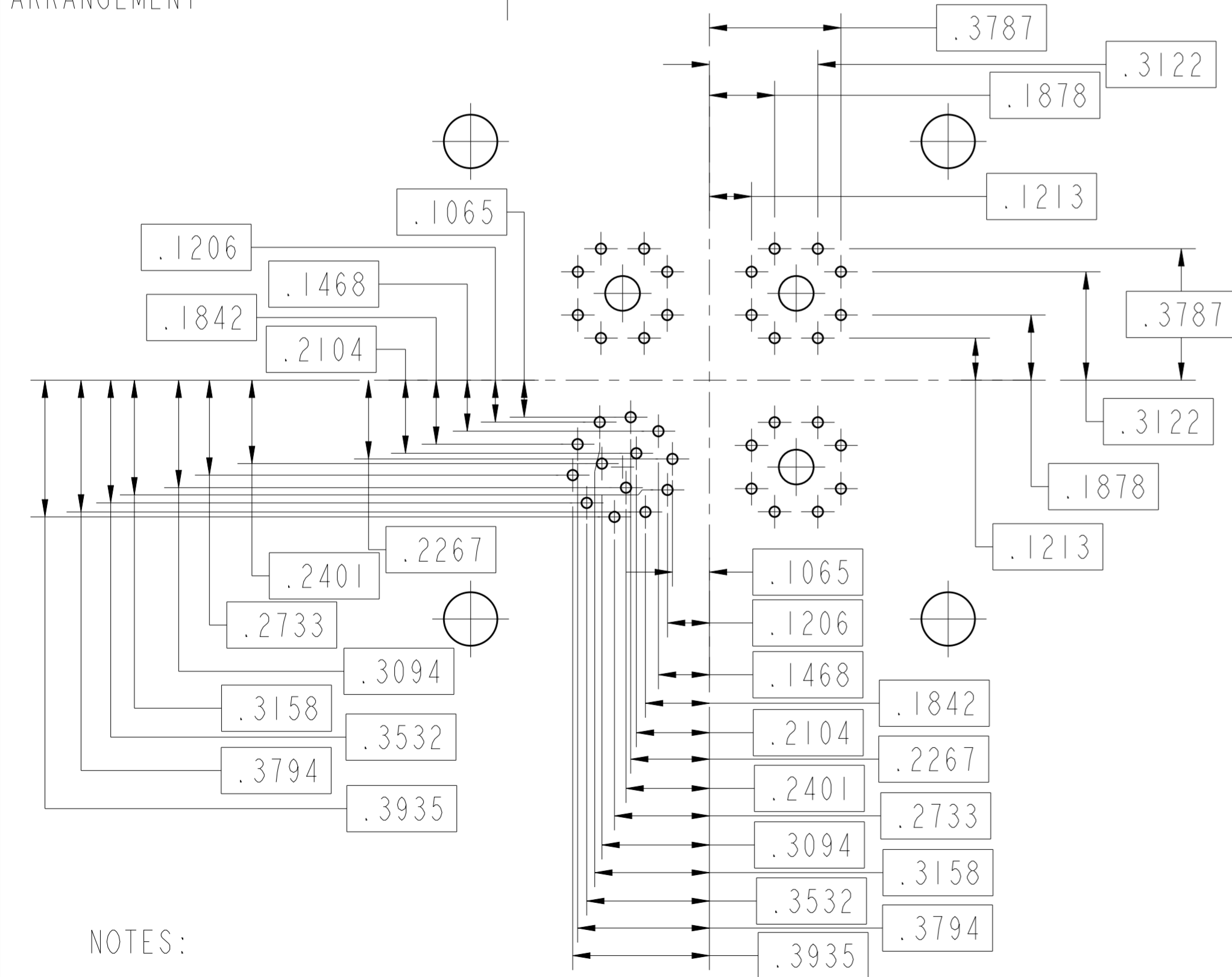

CONTACT CONFIGURATION IDENTIFIER	CONTACT LENGTH ±.025	CONTACT ONE DIAMETER ±.003	CONTACT TWO DIAMETER ±.003	PLATING
A	.634 ALUMINUM SHELLS .623 COMPOSITE SHELLS	.025	.095	GOLD OVER NICKEL
B	TBD			
C	TBD			
D	TBD			

NOTES:

1. THIS PAGE IS FOR CONTACT TERMINATION CODE A THROUGH Y.
 SEE PAGE 2 FOR PART NUMBER BREAKDOWN.

THIS DRAWING IS A CONTROLLED DOCUMENT.

DWN	JPF	140218
CHK	JPF	160122
APVD	AR	160122

STE TE Connectivity

NAME: CONNECTOR, RECEPTACLE
 FLANGE MOUNT
 2599 ARRANGEMENT

SIZE	A2	CAGE CODE	00779	DRAWING NO	C-CFX20x2599xxx	RESTRICTED TO	-
CUSTOMER DRAWING	SCALE		2.500	SHEET	6	OF	6
						REV	B

单击下面可查看定价，库存，交付和生命周期等信息

[>>TE Connectivity\(泰科\)](#)