

THIS DRAWING IS UNPUBLISHED. RELEASED FOR PUBLICATION
 © COPYRIGHT - By - ALL RIGHTS RESERVED.

LOC		DIST		REVISIONS			
P	LTR	DESCRIPTION		DATE	DWN	APVD	
	C	REV PER ECO-15-017559		06JAN16	KG	PD	

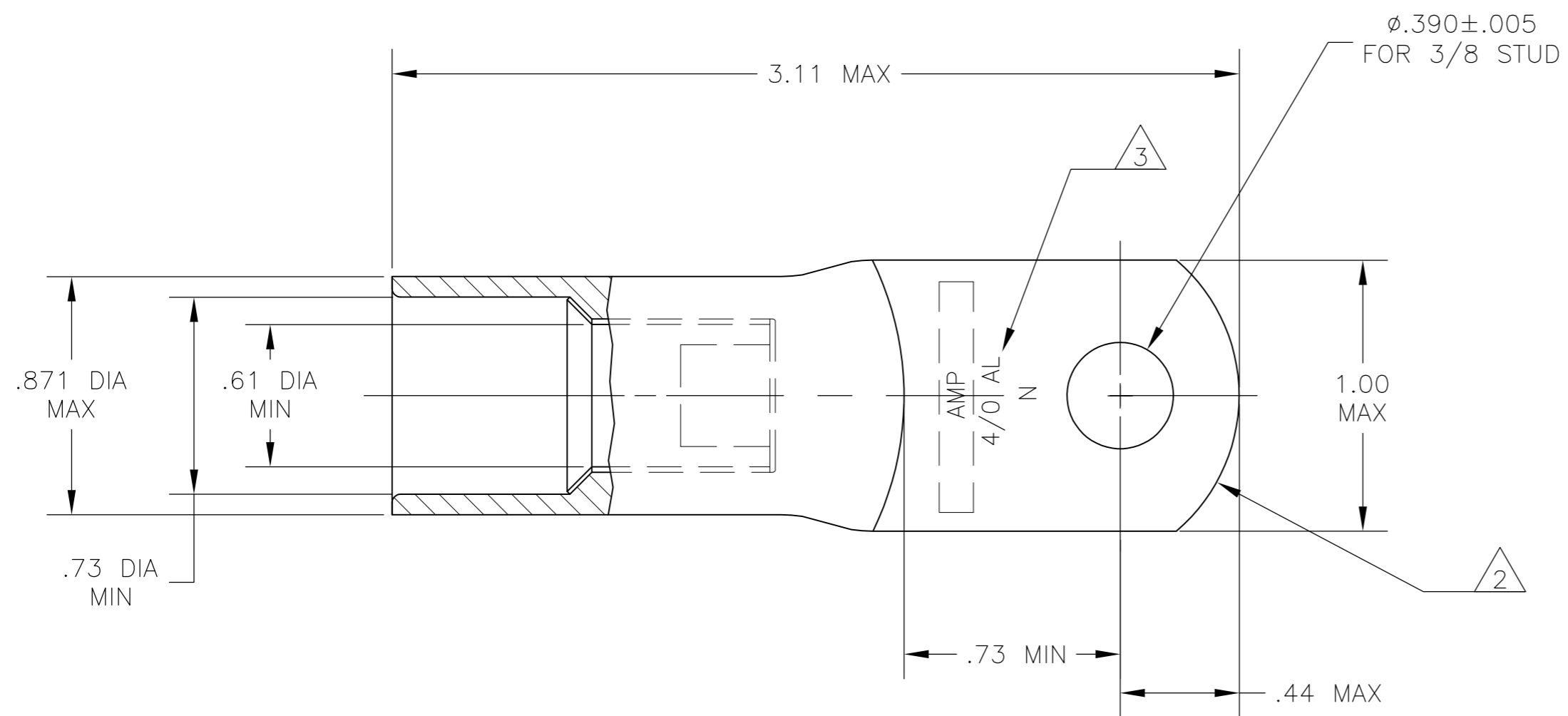

- 1 WIRE INSULATION: .590-.683 DIA
- 2 THE TONGUE RADIUS FEATURE IS NOT A TOOLING CONTROLLED DIMENSION AND MAY NOT BE A TRUE RADIUS.
- 3 STAMP "AMP 4/0 AL N" SIZE AND LOCATION APPROX AS SHOWN

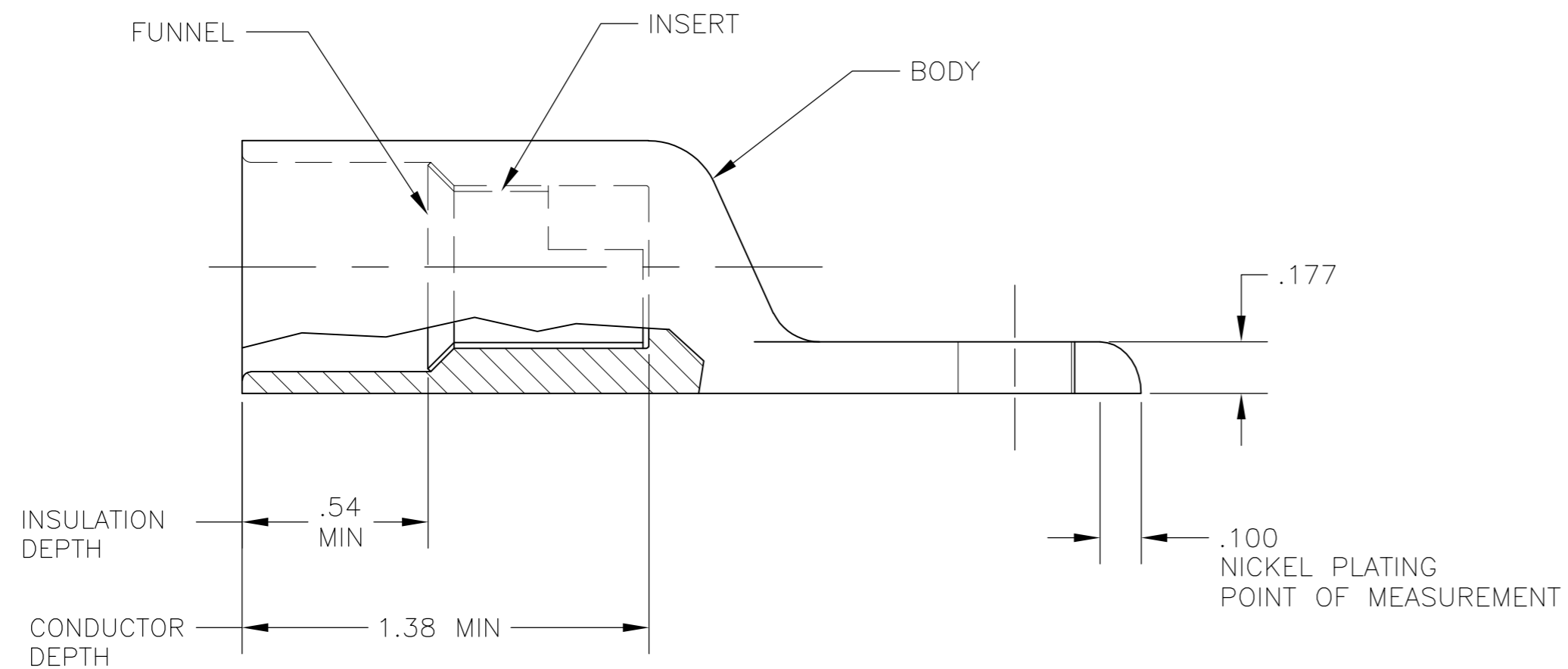

INSERT & FUNNEL: BRASS MIL-C-50 NICKEL PL QQ-N-290 .000300 AVG THK	1958054-1
BODY: COPPER ASTM-B187 ANNEALED NICKEL PL .000300 MIN THK PER QQ-N-290	
MATERIAL & FINISH	PART NO.

THIS DRAWING IS A CONTROLLED DOCUMENT.		DWN jr ruth 08JAN07		
DIMENSIONS: INCHES		CHK JOHN KNOLL 08JAN07		
TOLERANCES UNLESS OTHERWISE SPECIFIED:		APVD JOHN KNOLL 08JAN07	NAME	
0 PLC ± -		PRODUCT SPEC	WIRE TERMINAL, RING TONGUE, SEALED COPALUM, HIGH TEMP, WIRE SIZE: 4/0 AL	
1 PLC ± -		APPLICATION SPEC	SIZE	CAGE CODE
2 PLC ± .01			A2	00779
3 PLC ± .008			DRAWING NO	
4 PLC ± -			C-1958054	
ANGLES ± -		WEIGHT 100 GRAMS	RESTRICTED TO	
FINISH		CUSTOMER DRAWING	SCALE 2:1	SHEET 1 of 1
SEE TABLE			REV C	

单击下面可查看定价，库存，交付和生命周期等信息

[>>TE Connectivity\(泰科\)](#)