

THIS DRAWING IS UNPUBLISHED. RELEASED FOR PUBLICATION
 © COPYRIGHT BY TYCO ELECTRONICS CORPORATION. ALL RIGHTS RESERVED.

LOC	DIST	REVISIONS			
P	LTR	DESCRIPTION	DATE	DWN	APVD
AF	50	B1	REVISED PER ECR-08-000443	09JAN08	HMR PD

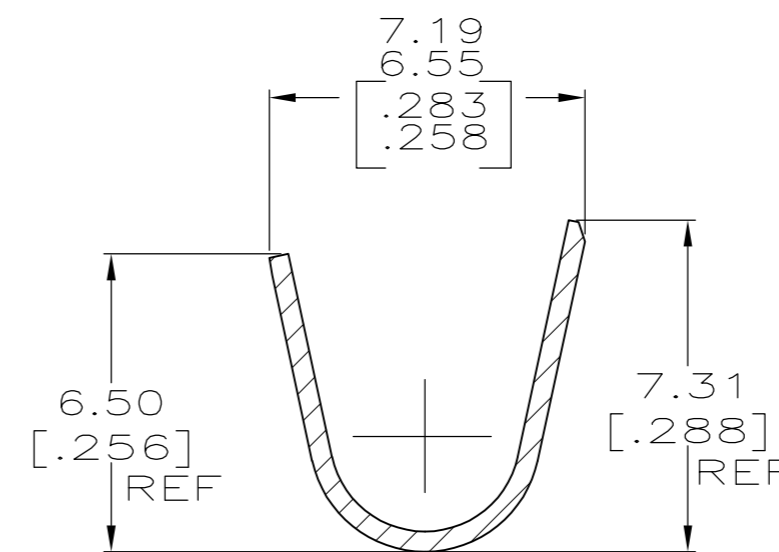
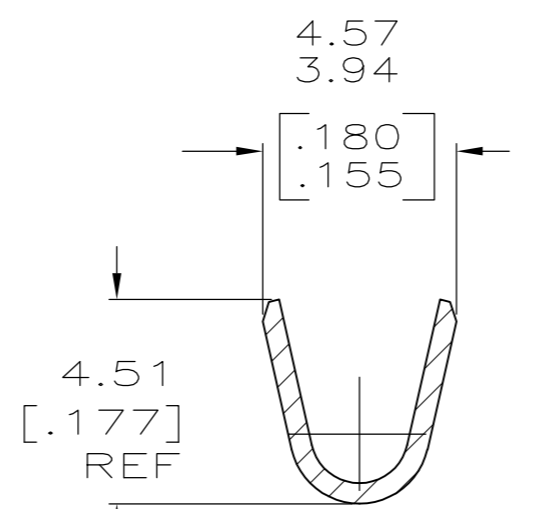
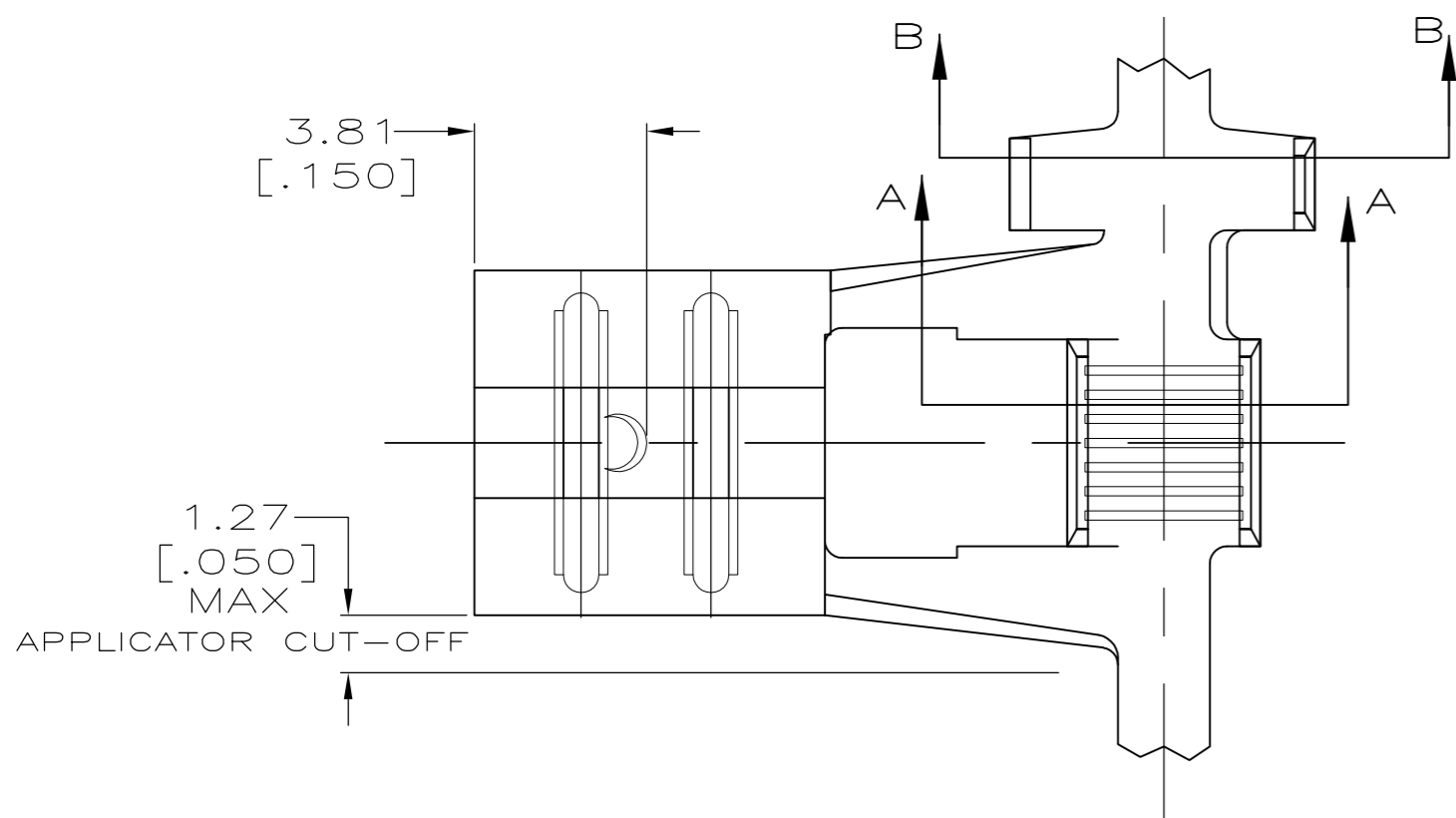

SECTION A-A

SECTION B-B

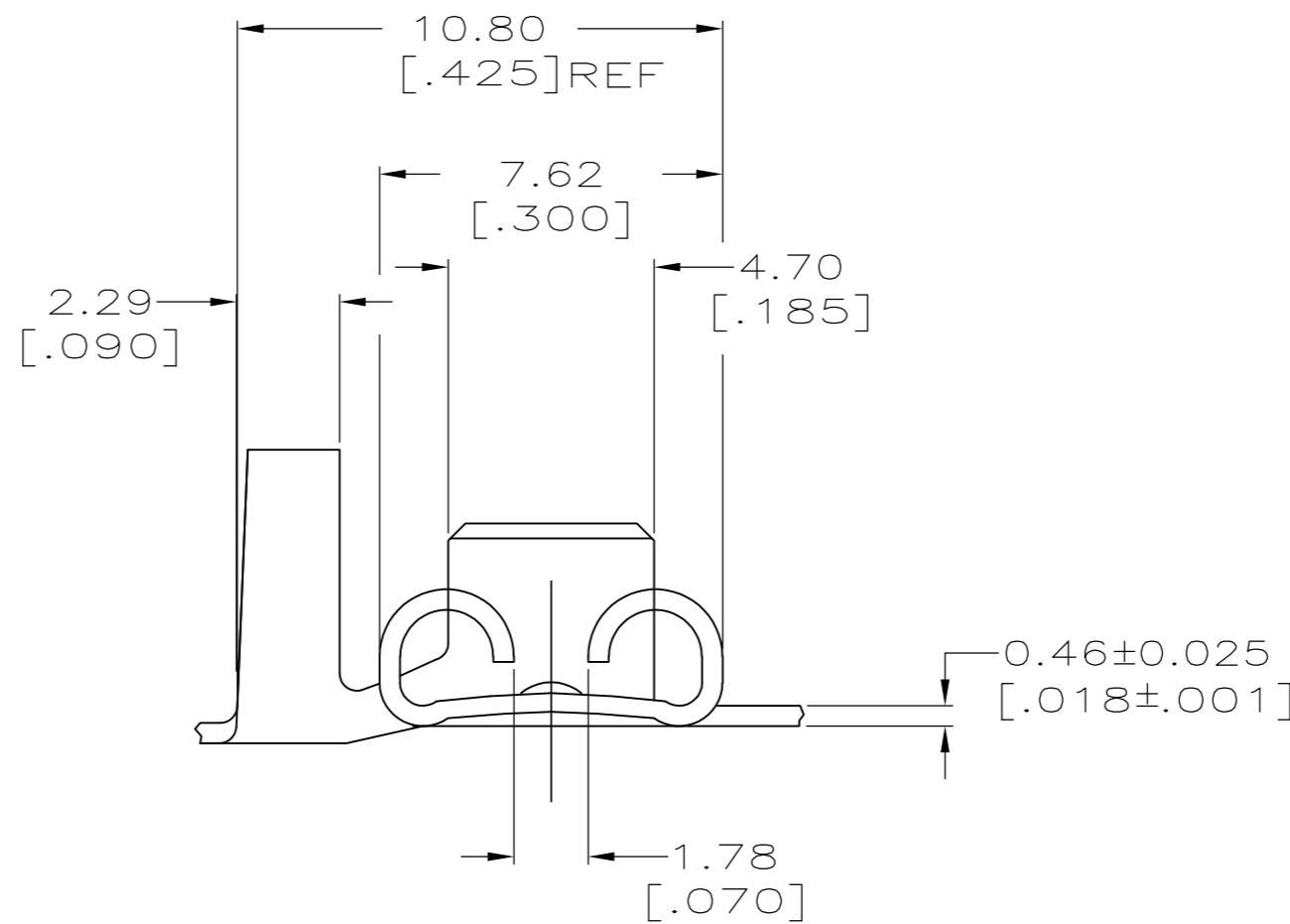
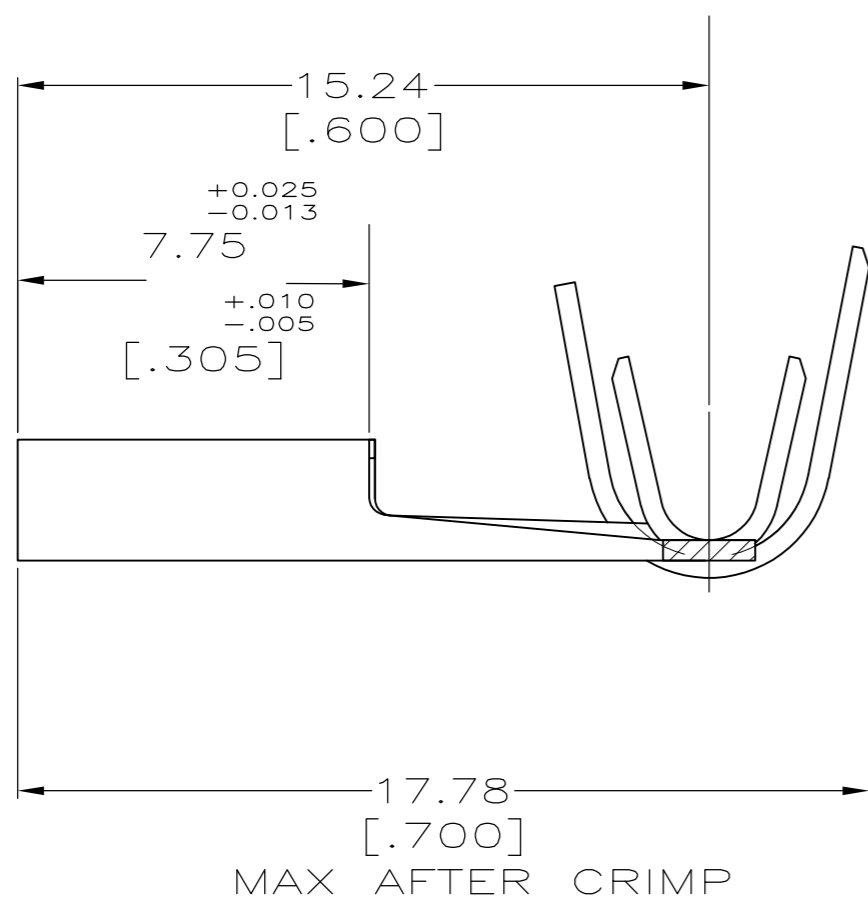

- 1 CONTINUOUS STRIP ON REELS
- 2 MATING TAB THK TO BE 0.813±0.025 [.032±.001].
- 3 WIRE SIZE IS [#16-#12] AWG.
- 4 INSULATION RANGE IS 3.05-4.32 [.120-.170] DIA.

63944

B

A

63944-1
 PART NO.

THIS DRAWING IS A CONTROLLED DOCUMENT.		DWN	JR RUTH	11/04/96	Tyco Electronics Corporation Harrisburg, PA 17105-3608								
DIMENSIONS: mm [INCHES]		CHK	MS FEHER	11/04/96									
TOLERANCES UNLESS OTHERWISE SPECIFIED:		APVD	P DESANTIS	11/04/96									
0 PLC ± - 1 PLC ± - 2 PLC ± 0.25 [.010] 3 PLC ± - 4 PLC ± - ANGLES ± -		PRODUCT SPEC	NAME			RECEPTACLE, FASTON, FLAG, AMPLIVAR, 6.35 [.250] SERIES							
MATERIAL	H03 PHOS BRONZE	FINISH	0.002032 [.000080] MIN TIN	WEIGHT	-	SIZE	A2	CAGE CODE	00779	DRAWING NO	C=63944	RESTRICTED TO	-
CUSTOMER DRAWING				SCALE	6:1	SHEET	1 OF 1	REV	B1				

单击下面可查看定价，库存，交付和生命周期等信息

[>>TE Connectivity\(泰科\)](#)