

THIS DRAWING IS UNPUBLISHED. RELEASED FOR PUBLICATION SEP. 2005.
 © COPYRIGHT 2005 By - ALL RIGHTS RESERVED.

LOC		DIST		REVISIONS 変更		
P	LTR	DESCRIPTION		DATE	DWN	APVD
-	-	S	REVISED PER ECR-15-016490	11NOV2015	T.Z	H.W

- 1 CONTACT COPLANALITY IS 0.1 MAX.
- 2 THIS DIMENSION MEANS CENTER OF THE POCKET.
- 3 M3 TAPPING + BVTP RECOMMENDED TORQUE: 68.6N (7Kgf) MAX.
- 4 FINISH
CONTACT: V μm MIN. Au PL. ON CONTACT AREA (V: SEE TABLE)
0.03~0.1 μm Au PL. ON TERMINAL AREA
Ni UNDER PL. ALL OVER
SHELL: Sn PL. (MATTE) ALL OVER
Ni UNDER PL. ALL OVER
- 5 SCREW SIZE
- 6 QTY PRINT ON THE LABEL. (EMBOSS PACKING)

- 1 コンタクトコプラナリティーは 0.1 以下。
- 2 本寸法はポケットの中心を表す。
- 3 M3 TAPPING + BVTP 推奨トルク: 68.6N (7Kgf) 以下。
- 4 仕上
コンタクト: コンタクトエリアに V μm 以上の 金めっき (V: 表参照)
ターミナルエリアに 0.03~0.1 μm の金めっき
ニッケル下地めっきを施す
シェル: すずめっき (つや消し)
ニッケル下地めっきを施す
- 5 スクリューサイズ
- 6 数量はラベルに印字される (EMBOSS 梱包)

0.3	-	70	1.9	-	-	-	-	33.5	37.5	9.32	0.4	32	28.4	14.2	16	WITHOUT TAPE	WITHOUT FLANGE	THROUGH HOLE	(SEE SHEET 2)	SOFT TRAY (SEE SHEET 11)	6-1903015-3
0.76	M3 x 0.5	70	1.9	46	138	6-23	46	-	-	-	-	-	-	-	-	WITH TAPE	WITH FLANGE	THROUGH HOLE	(SEE SHEET 3)	SOFT TRAY (SEE SHEET 7)	9-1903015-4
0.3	M3 x 0.5	200	1.9	-	-	-	-	45.5	49.5	18.3	0.5	44	40.4	20.2	20	WITH TAPE	WITH FLANGE	THROUGH HOLE	(SEE SHEET 3)	EMBOSS (SEE SHEET 6)	9-1903015-3
0.3	M3 x 0.5	70	1.9	-	-	-	-	-	-	-	-	-	-	-	-	WITHOUT TAPE	WITH FLANGE	THROUGH HOLE	(SEE SHEET 3)	SOFT TRAY (SEE SHEET 10)	8-1903015-4
0.1	-	550	1.9	-	-	-	-	33.5	37.5	9.32	0.4	32	28.4	14.2	16	WITHOUT TAPE	WITHOUT FLANGE	THROUGH HOLE	(SEE SHEET 2)	EMBOSS (SEE SHEET 6)	7-1903015-1
0.3	M3 x 0.5	200	1.9	-	-	-	-	45.5	49.5	18.3	0.5	44	40.4	20.2	20	WITHOUT TAPE	WITH FLANGE	FULL SMT	(SEE SHEET 5)	EMBOSS (SEE SHEET 6)	5-1903015-9
0.3	-	550	0.8	-	-	-	-	33.5	37.5	9.32	0.4	32	28.4	14.2	16	WITHOUT TAPE	WITHOUT FLANGE	THROUGH HOLE	(SEE SHEET 2)	EMBOSS (SEE SHEET 6)	5-1903015-5
0.3	M3 x 0.5	70	1.9	46	138	6-23	46	-	-	-	-	-	-	-	-	WITHOUT TAPE	WITH FLANGE	THROUGH HOLE	(SEE SHEET 3)	SOFT TRAY (SEE SHEET 7)	5-1903015-4
0.3	M3 x 0.5	200	1.9	-	-	-	-	45.5	49.5	18.3	0.5	44	40.4	20.2	20	WITHOUT TAPE	WITH FLANGE	THROUGH HOLE	(SEE SHEET 3)	EMBOSS (SEE SHEET 6)	5-1903015-3
0.3	φ2.65±0.3	70	1.9	46	138	6-23	46	-	-	-	-	-	-	-	-	WITHOUT TAPE	WITH FLANGE	THROUGH HOLE	(SEE SHEET 3)	SOFT TRAY (SEE SHEET 7)	5-1903015-2
0.3	-	400	1.9	-	-	-	-	33.5	37.5	9.32	0.4	32	28.4	14.2	16	WITHOUT TAPE	WITHOUT FLANGE	THROUGH HOLE	(SEE SHEET 2)	EMBOSS (SEE SHEET 6)	5-1903015-1
0.3	M3 x 0.5	70	1.0	46	138	6-23	46	-	-	-	-	-	-	-	-	WITHOUT TAPE	WITH FLANGE	THROUGH HOLE	(SEE SHEET 3)	SOFT TRAY (SEE SHEET 7)	4-1903015-1
0.76	-	400	1.2	-	-	-	-	33.5	37.5	9.32	0.4	32	28.4	14.2	16	WITHOUT TAPE	WITHOUT FLANGE	THROUGH HOLE	(SEE SHEET 2)	EMBOSS (SEE SHEET 6)	2-1903015-2
0.76	M3 x 0.5	70	1.9	-	-	-	-	-	-	-	-	-	-	-	-	WITHOUT TAPE	WITH FLANGE	THROUGH HOLE	(SEE SHEET 3)	SOFT TRAY (SEE SHEET 9)	1903015-8
0.76	φ2.65±0.3	70	1.9	-	-	-	-	-	-	-	-	-	-	-	-	WITHOUT TAPE	WITH FLANGE	THROUGH HOLE	(SEE SHEET 3)	SOFT TRAY (SEE SHEET 9)	1903015-7
0.76	M3 x 0.5	50	1.9	54.4	120	4-30	54.4	-	-	-	-	-	-	-	-	WITHOUT TAPE	WITH FLANGE	THROUGH HOLE	(SEE SHEET 3)	SOFT TRAY (SEE SHEET 9)	1903015-5
0.76	M3 x 0.5	70	1.9	46	138	6-23	46	-	-	-	-	-	-	-	-	WITHOUT TAPE	WITH FLANGE	THROUGH HOLE	(SEE SHEET 4)	SOFT TRAY (SEE SHEET 8)	1903015-4
0.76	M3 x 0.5	200	1.9	-	-	-	-	45.5	49.5	18.3	0.5	44	40.4	20.2	20	WITHOUT TAPE	WITH FLANGE	THROUGH HOLE	(SEE SHEET 4)	EMBOSS (SEE SHEET 6)	1903015-3
0.76	φ2.65±0.3	70	1.9	46	138	6-23	46	-	-	-	-	-	-	-	-	WITHOUT TAPE	WITH FLANGE	THROUGH HOLE	(SEE SHEET 3)	SOFT TRAY (SEE SHEET 7)	1903015-2
0.76	-	400	1.9	-	-	-	-	33.5	37.5	9.32	0.4	32	28.4	14.2	16	WITHOUT TAPE	WITHOUT FLANGE	THROUGH HOLE	(SEE SHEET 2)	EMBOSS (SEE SHEET 6)	1903015-1
V	U	T	AA	S	R	P	N	M	L	K	J	H	G	F	E	POLYIMIDE TAPE	FLANGE	SHELL TYPE	CONNECTOR	PACKING	PART NUMBER

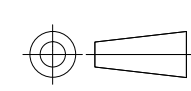
4 Au PL. 5 SCREW SIZE QTY DIMENSION	THIS DRAWING IS A CONTROLLED DOCUMENT.		DWN R.MURAYAMA 26SEP2005 CHK T.KIMURA 26SEP2005 APVD T.KIMURA 26SEP2005		 TE Connectivity HDMI 19 POS RECEPTACLE ASSY SMT SHORT TYPE
	DIMENSIONS: 単位: 概 mm 	TOLERANCES UNLESS OTHERWISE SPECIFIED: 一般公差 0 PLC ± 1 PLC ± 2 PLC ± 3 PLC ± 4 PLC ± ANGLES ±	PRODUCT SPEC 製品規格 108-78180-2 APPLICATION SPEC 取付適用規格	NAME 名称 SIZE CAGE CODE DRAWING NO 番号 RESTRICTED TO	
MATERIAL 材料	FINISH 仕上	WEIGHT	CUSTOMER DRAWING SCALE 尺度 4:1 SHEET 1 OF 12 REV S		

THIS DRAWING IS UNPUBLISHED. RELEASED FOR PUBLICATION SEP ,2005.
 © COPYRIGHT 2005 By - ALL RIGHTS RESERVED.

LOC	DIST	P	LTR	REVISIONS 変更	DATE	DWN	APVD
-	-	-	-	DESCRIPTION	-	-	-
				SEE SHEET 1			

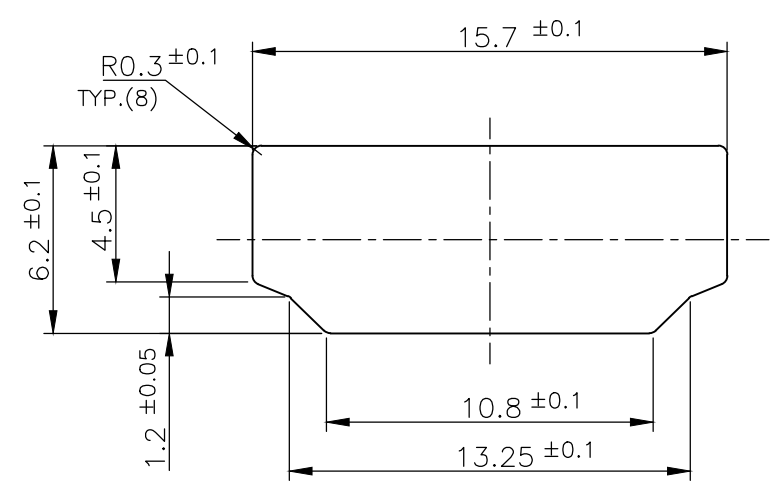
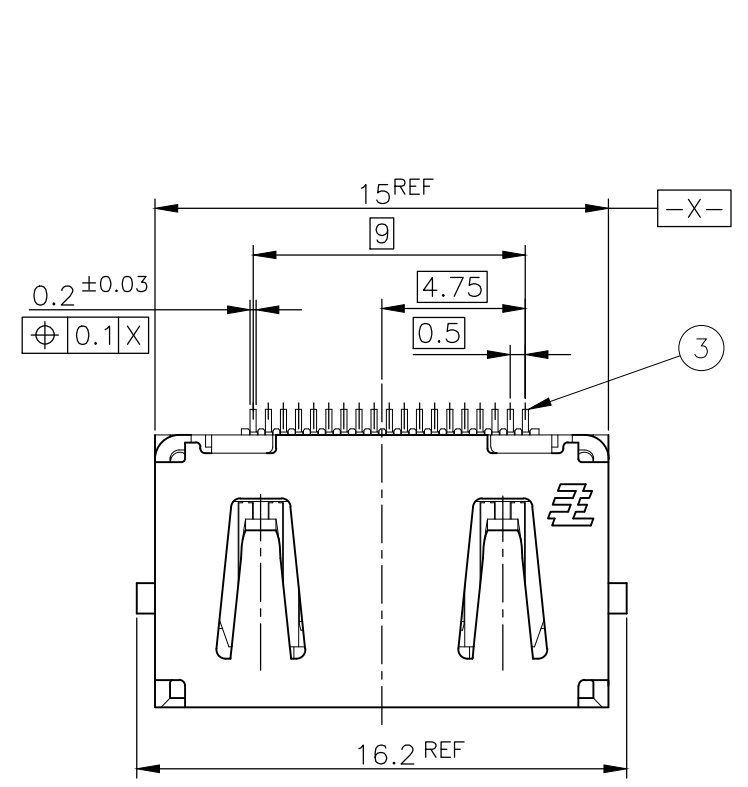

PANEL CUT OUT DIMENSION (REFERENCE)

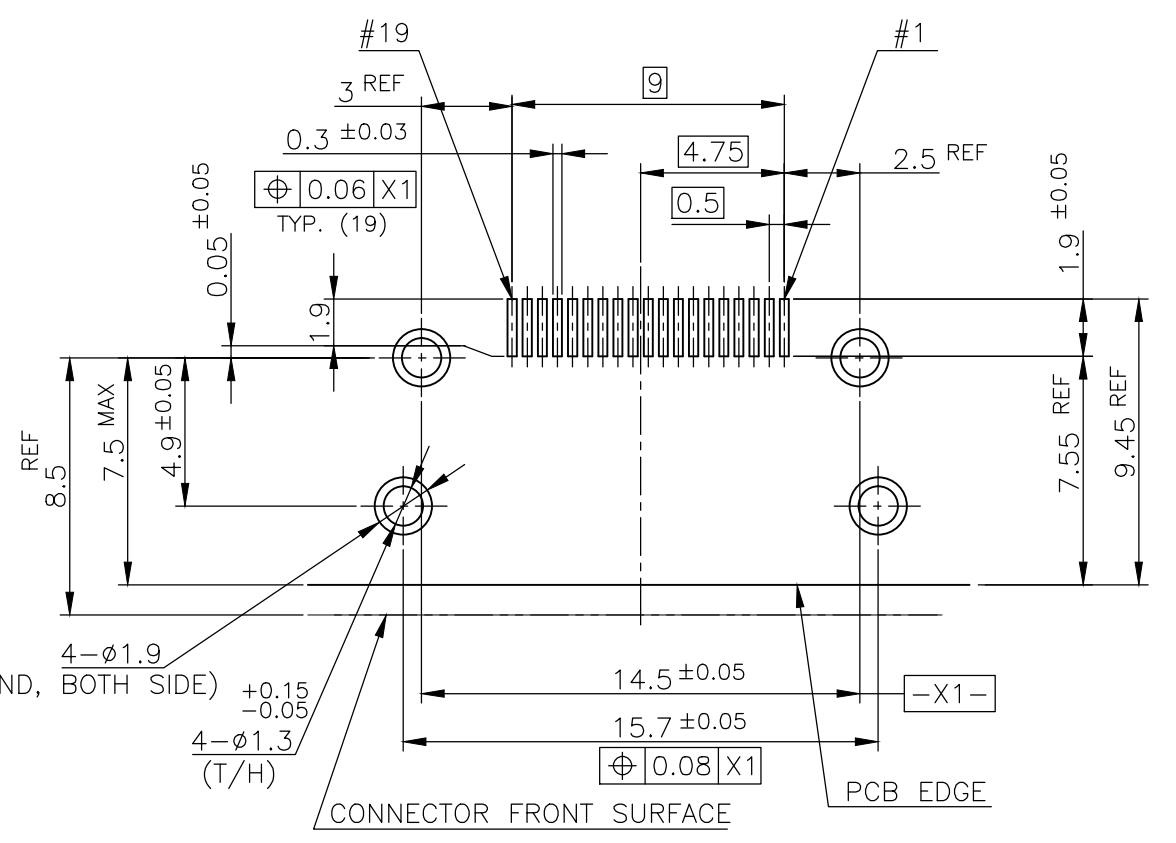

P.C.B LAYOUT (REFERENCE)
 SHOWN AS CONNECTOR MOUNTING SIDE
 TOLERANCE: NON-CUMULATIVE

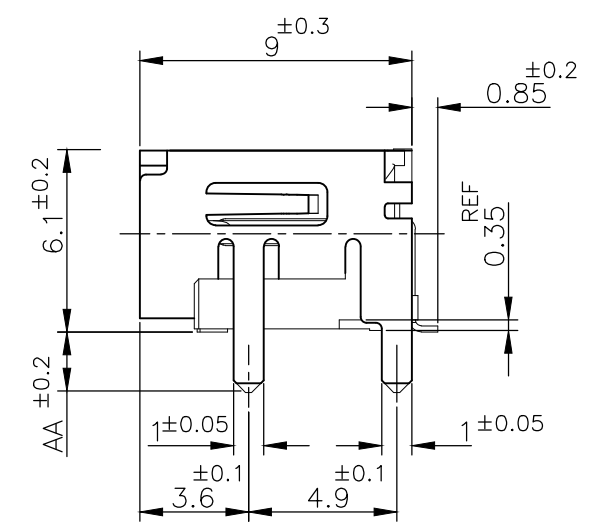
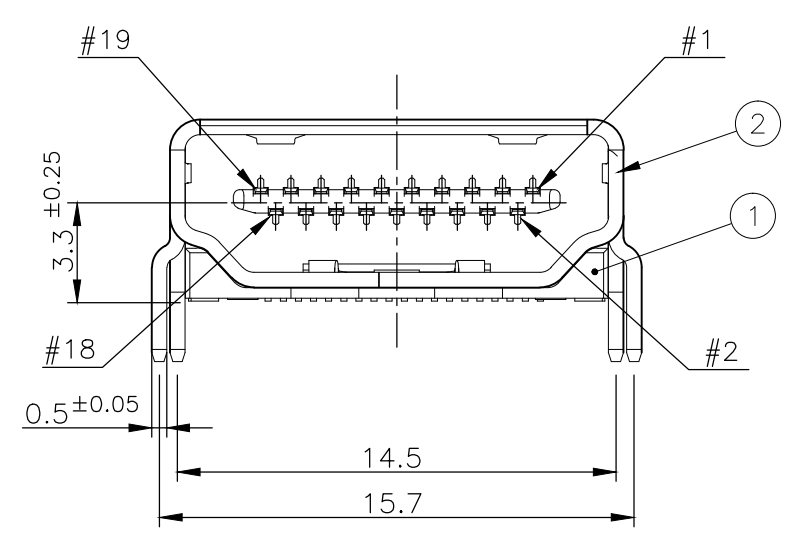

CONNECTOR: WITHOUT FLANGE THROUGH HOLE TYPE

BRASS	CONTACT	③
PHOSPHOR BRONZE	SHELL	②
GLASS FILLED LCP UL94V-0, BLACK COLOR	HOUSING	①
MATERIAL	DESCRIPTION	ITEM

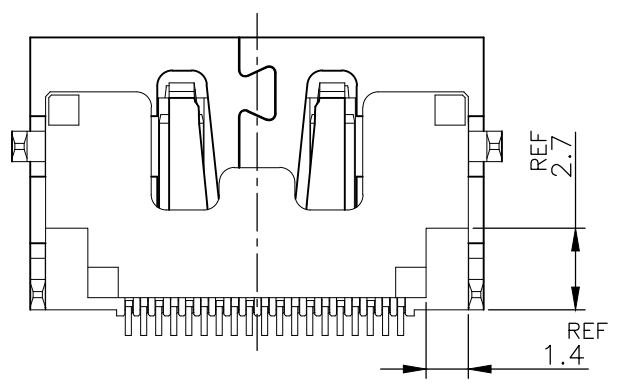

THIS DRAWING IS A CONTROLLED DOCUMENT.		DWN				
DIMENSIONS: 单位: 毫米 mm		CHK				
TOLERANCES UNLESS OTHERWISE SPECIFIED: 一般公差		APVD				
0 PLC ± 1 PLC ± 2 PLC ± 3 PLC ± 4 PLC ± ANGLES ±		NAME 名称				
MATERIAL 材料		FINISH 仕上	HDMI 19 POS RECEPTACLE ASSY SMT SHORT TYPE			
WEIGHT		CUSTOMER DRAWING	SIZE	CAGE CODE	DRAWING NO 番号	RESTRICTED TO
			A3	00779	G-1903015	-
			SCALE 尺度	4:1	SHEET	2 OF 12
					REV	S

LOC	DIST
-	-

REVISIONS			DATE	DWN	APVD
変更					
P	LTR	DESCRIPTION			
-	-	SEE SHEET 1	-	-	-

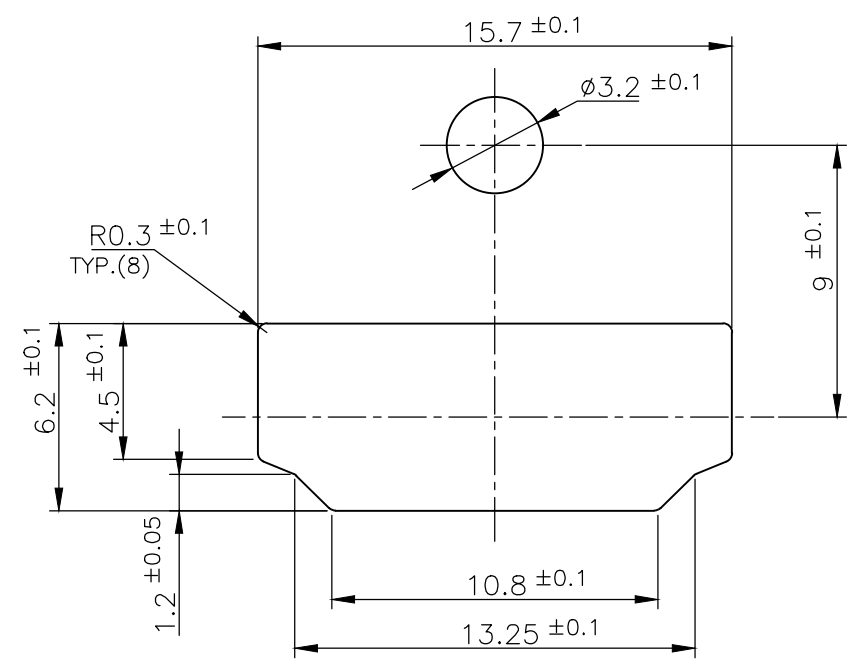
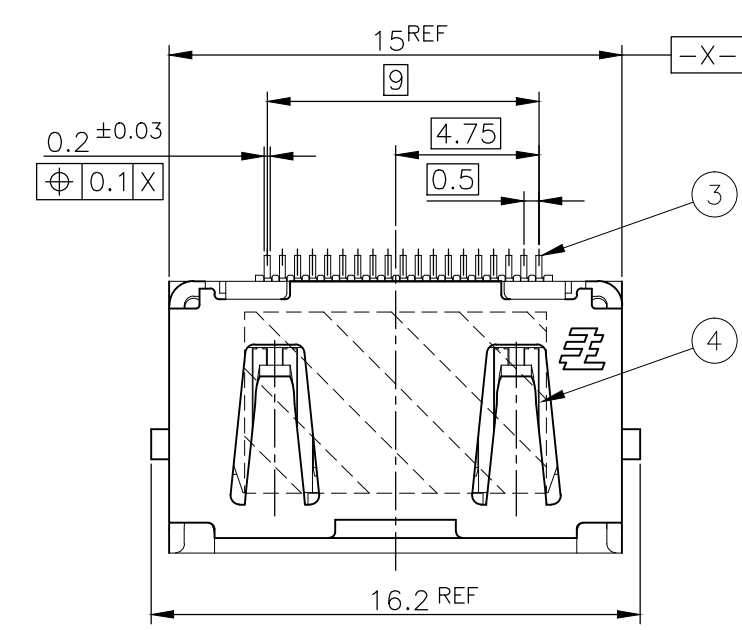

PANEL CUT OUT DIMENSION (REFERENCE)

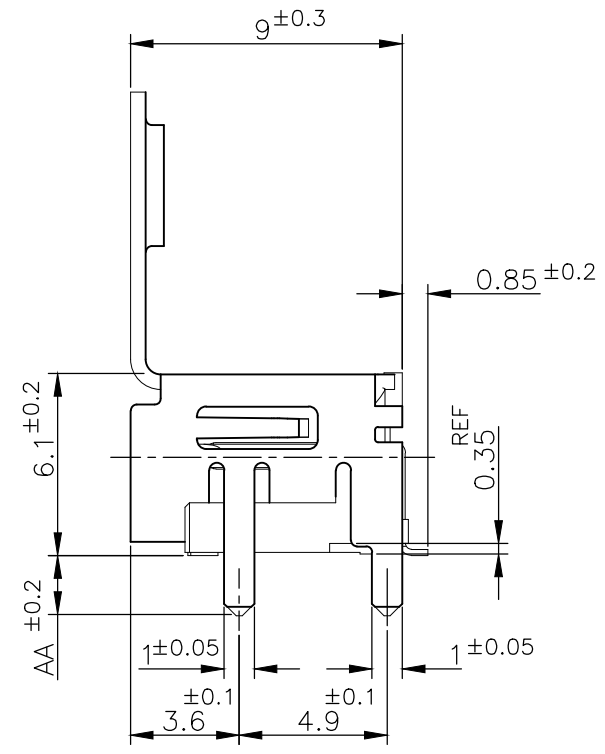
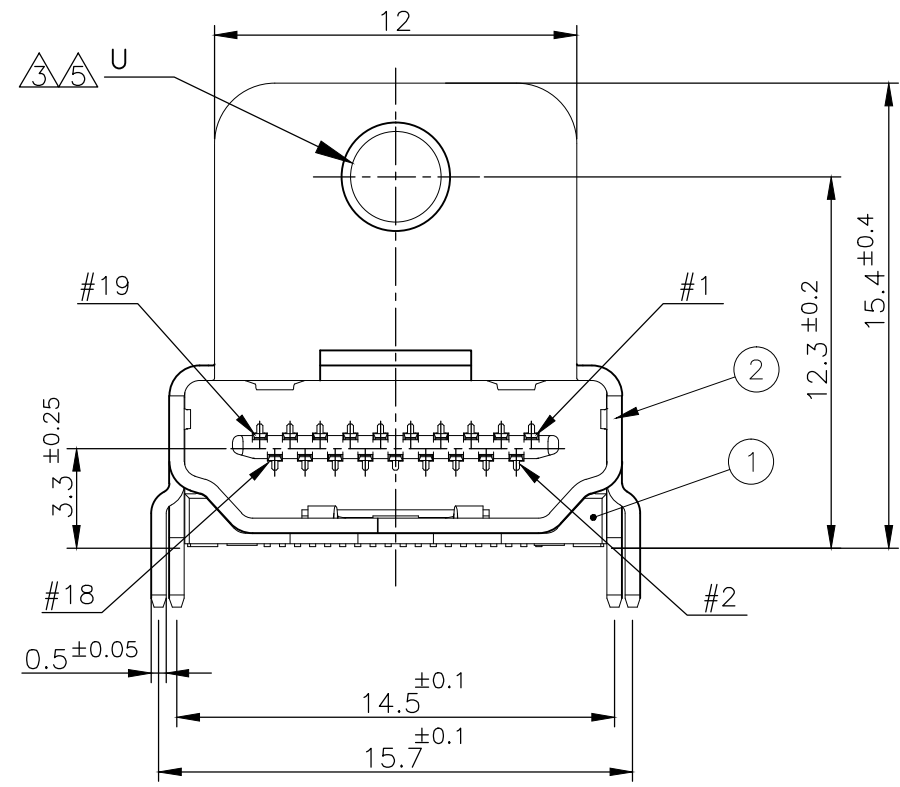

CONNECTOR: WITH FLANGE THROUGH HOLE TYPE

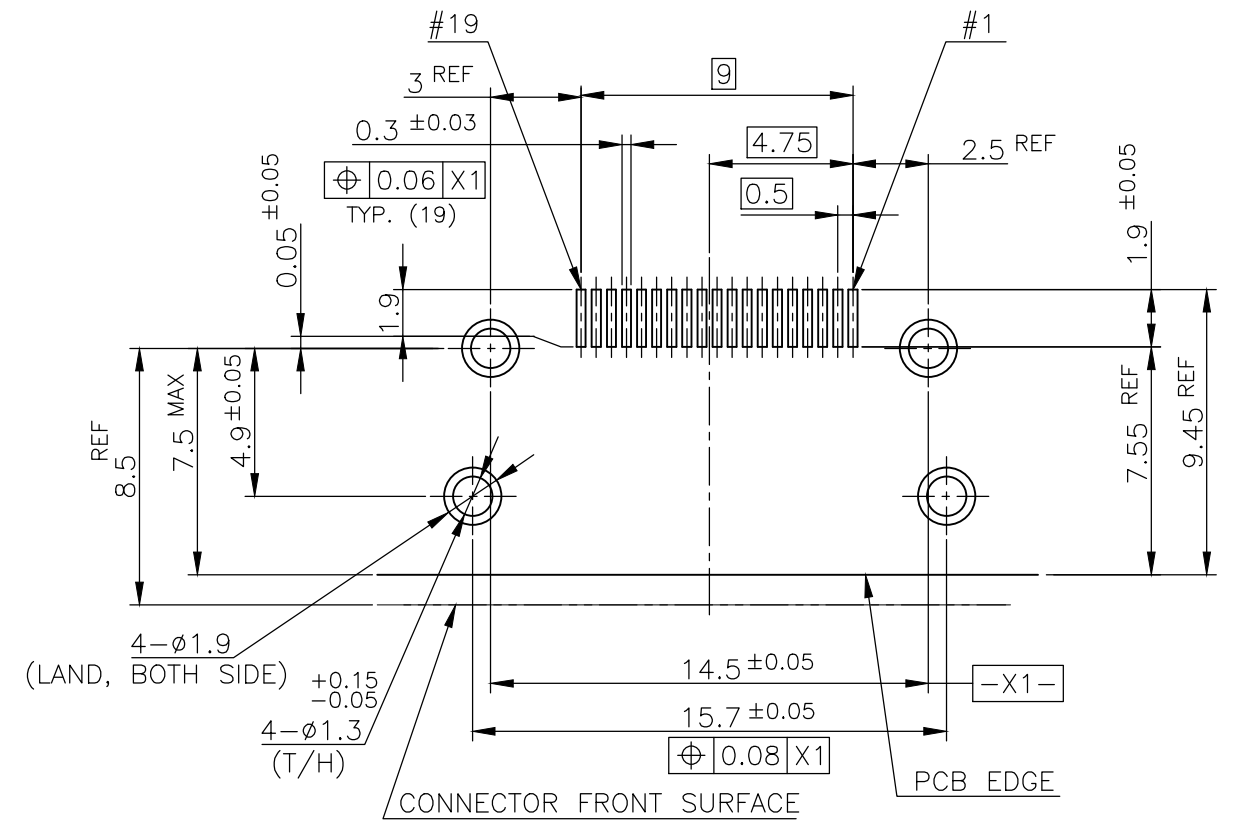

P.C.B LAYOUT (REFERENCE)
SHOWN AS CONNECTOR MOUNTING SIDE
TOLERANCE: NON-CUMULATIVE

POLYIMIDE	TAPE	(4)
BRASS	CONTACT	(3)
PHOSPHOR BRONZE	SHELL	(2)
GLASS FILLED LCP UL94V-0, BLACK COLOR	HOUSING	(1)
MATERIAL	DESCRIPTION	ITEM

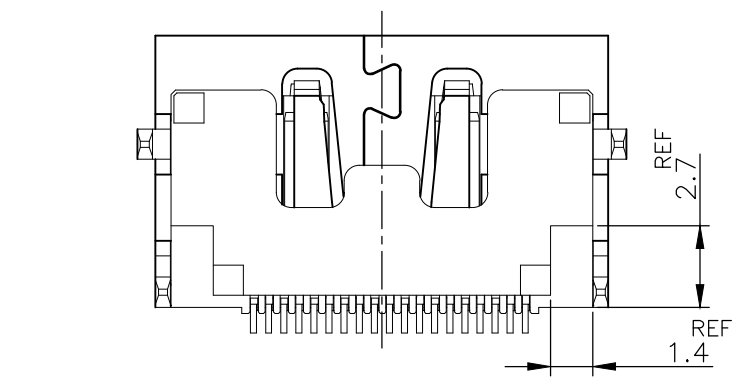

THIS DRAWING IS A CONTROLLED DOCUMENT.		DWN	
DIMENSIONS: 單位: 耗 mm		CHK	
TOLERANCES UNLESS OTHERWISE SPECIFIED: 一般公差		APVD	
0 PLC ±		PRODUCT SPEC 製品規格	NAME 名称
1 PLC ±		APPLICATION SPEC 取付適用規格	SIZE
2 PLC ±		WEIGHT	CAGE CODE
3 PLC ±			DRAWING NO 番号
4 PLC ±			RESTRICTED TO
ANGLES ±			
MATERIAL 材料			
FINISH 仕上			

STE TE Connectivity

HDMI 19 POS RECEPTACLE ASSY
SMT SHORT TYPE

A300779 G-1903015

CUSTOMER DRAWING

SCALE 4:1 SHEET 3 OF 12 REV S

THIS DRAWING IS UNPUBLISHED. RELEASED FOR PUBLICATION SEP, 2005.
 © COPYRIGHT 2005 By - ALL RIGHTS RESERVED.

LOC	DIST	REVISIONS			DATE	DWN	APVD
		P	LTR	DESCRIPTION			
-	-	-	-	SEE SHEET 1	-	-	-

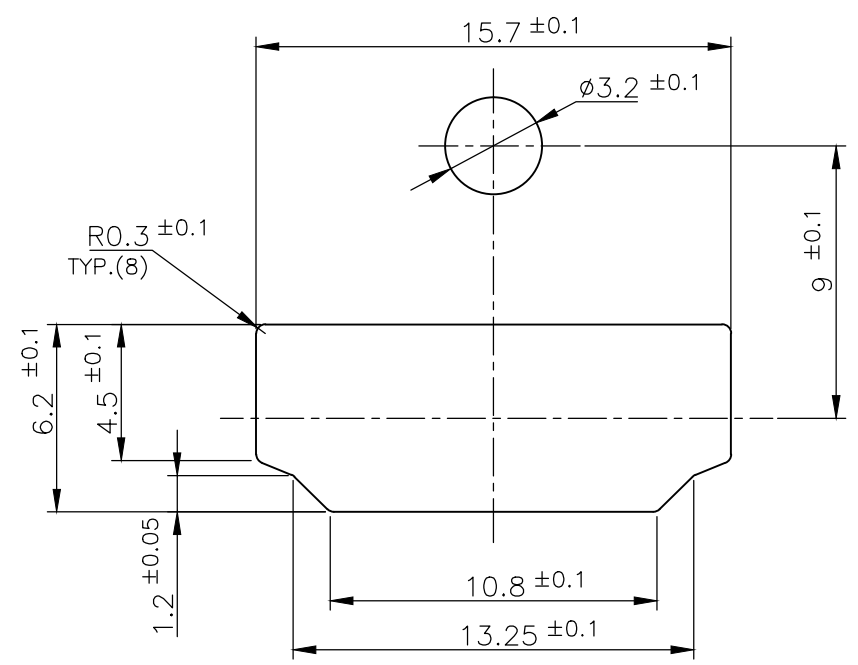
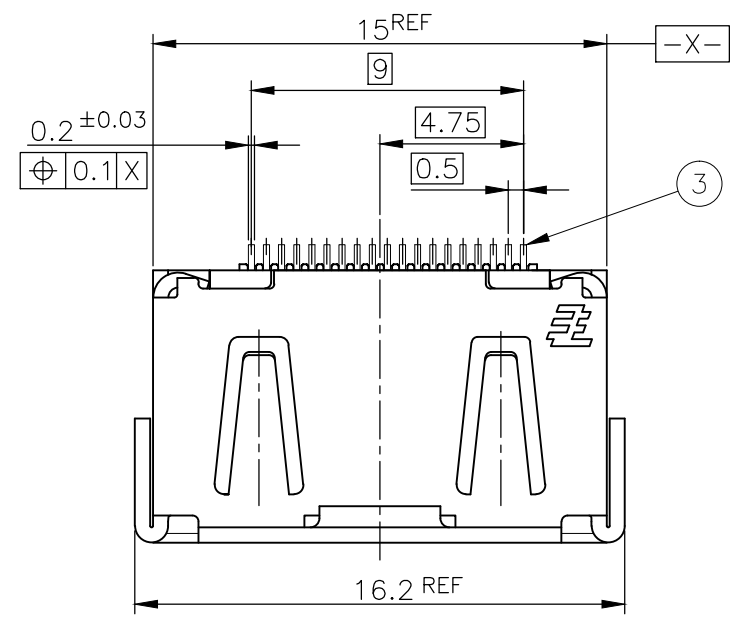

PANEL CUT OUT DIMENSION (REFERENCE)

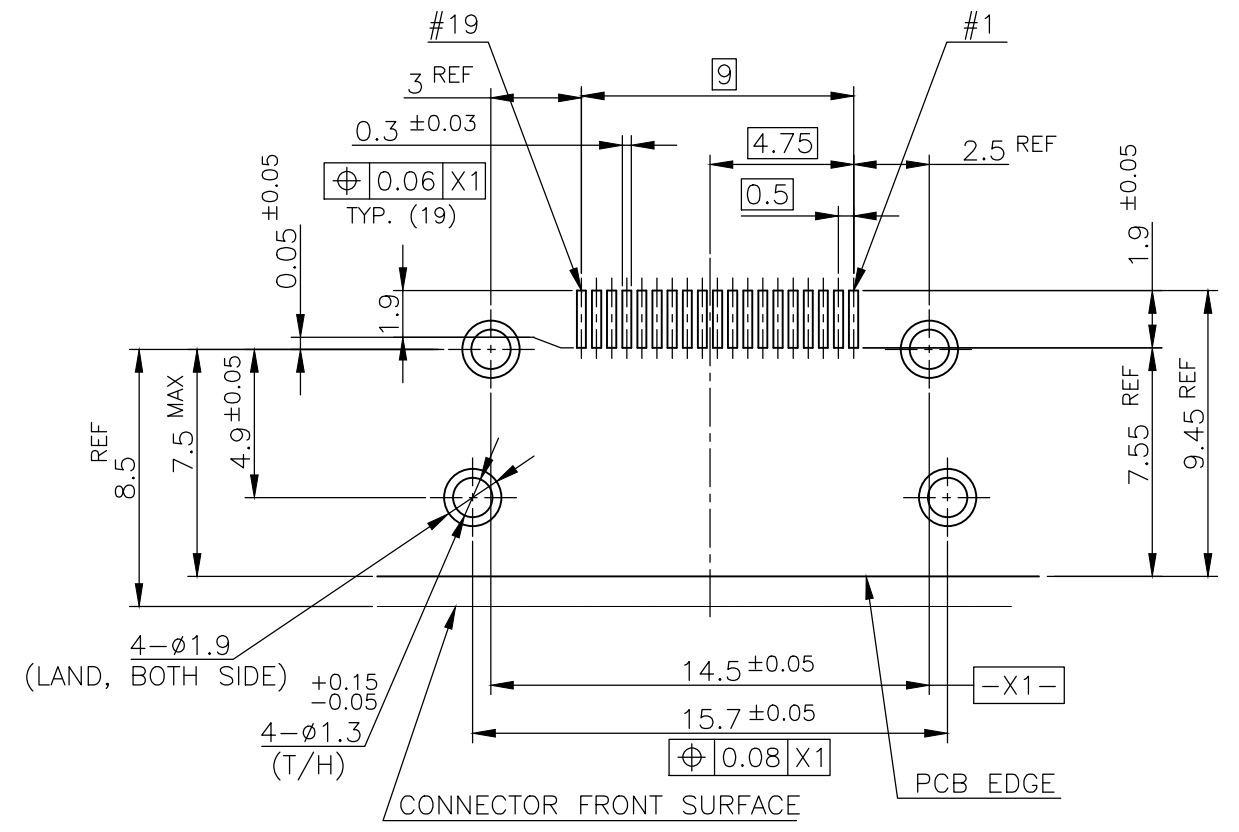

P.C.B LAYOUT (REFERENCE)
 SHOWN AS CONNECTOR MOUNTING SIDE
 TOLERANCE: NON-CUMULATIVE

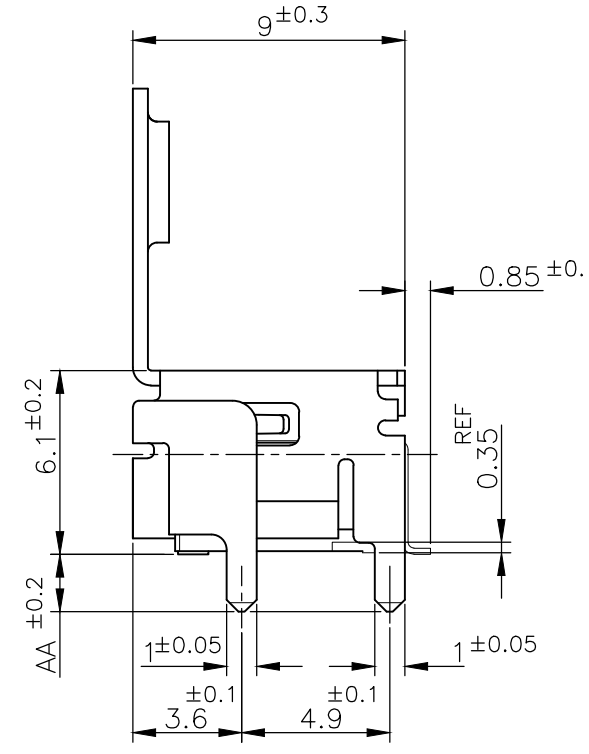
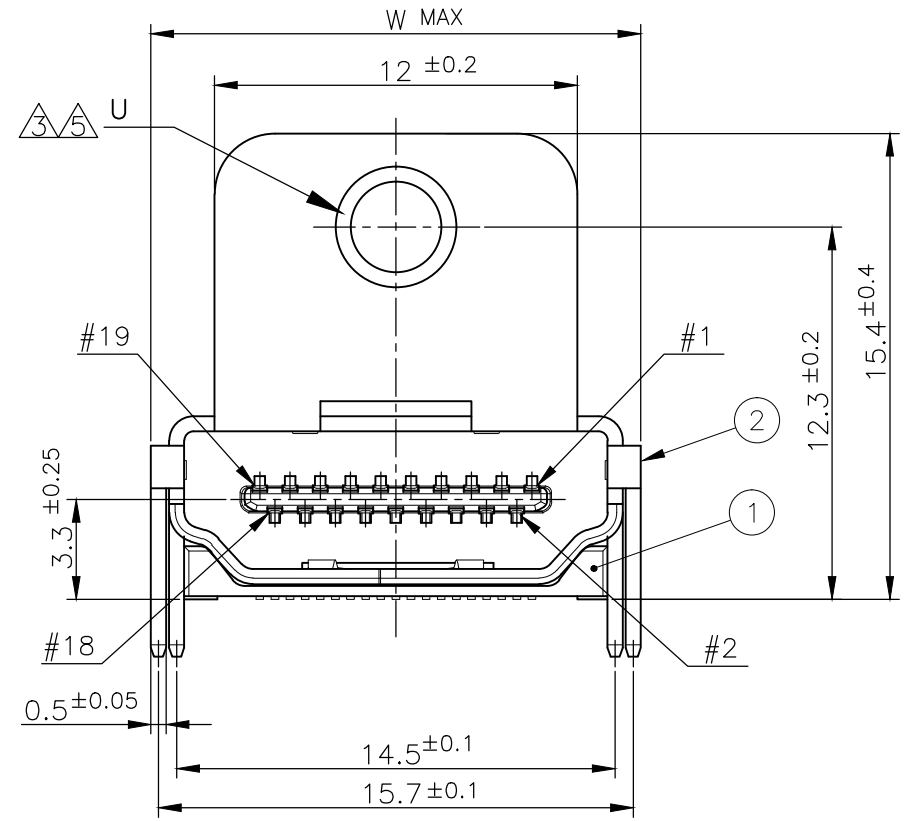

CONNECTOR: WITH FLANGE THROUGH HOLE TYPE

POLYIMIDE	TAPE	④
BRASS	CONTACT	③
PHOSPHOR BRONZE	SHELL	②
GLASS FILLED LCP UL94V-0, BLACK COLOR	HOUSING	①
MATERIAL	DESCRIPTION	ITEM

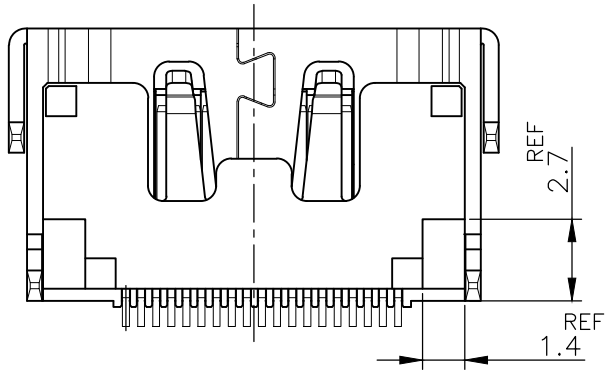

THIS DRAWING IS A CONTROLLED DOCUMENT.		DWN												
DIMENSIONS: 單位: 耗 mm		CHK												
TOLERANCES UNLESS OTHERWISE SPECIFIED: 一般公差		APVD												
<table border="1"> <tr><td>0 PLC</td><td>±</td></tr> <tr><td>1 PLC</td><td>±</td></tr> <tr><td>2 PLC</td><td>±</td></tr> <tr><td>3 PLC</td><td>±</td></tr> <tr><td>4 PLC</td><td>±</td></tr> <tr><td>ANGLES</td><td>±</td></tr> </table>		0 PLC				±	1 PLC	±	2 PLC	±	3 PLC	±	4 PLC	±
0 PLC	±													
1 PLC	±													
2 PLC	±													
3 PLC	±													
4 PLC	±													
ANGLES	±													
MATERIAL 材料		FINISH 仕上	HDMI 19 POS RECEPTACLE ASSY SMT SHORT TYPE											
WEIGHT		SIZE	CAGE CODE	DRAWING NO 番号	RESTRICTED TO									
CUSTOMER DRAWING		A300779		G-1903015	-									
SCALE 尺度 4:1		SHEET 4 OF 12		REV S										

THIS DRAWING IS UNPUBLISHED. RELEASED FOR PUBLICATION SEP ,2005.
 © COPYRIGHT 2005 By - ALL RIGHTS RESERVED.

LOC		DIST		REVISIONS			DATE	DWN	APVD
P	LTR	DESCRIPTION							
-	-	SEE SHEET 1			-	-	-	-	-

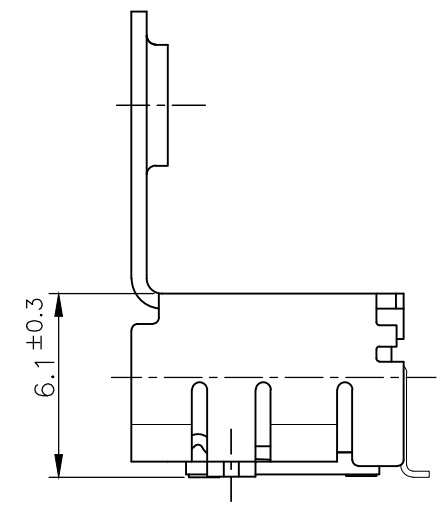
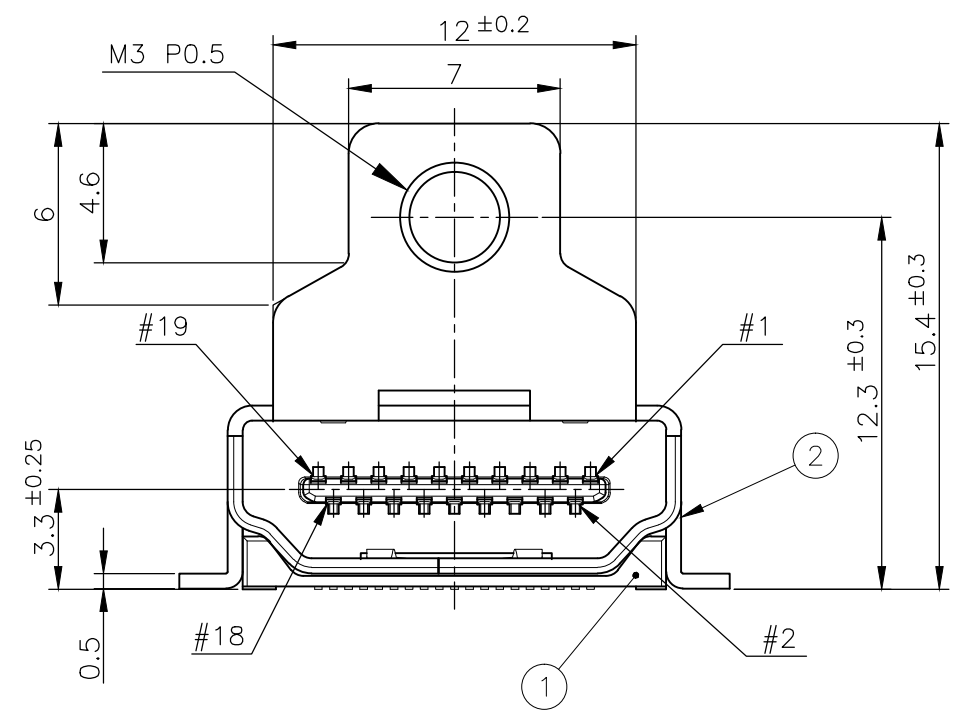
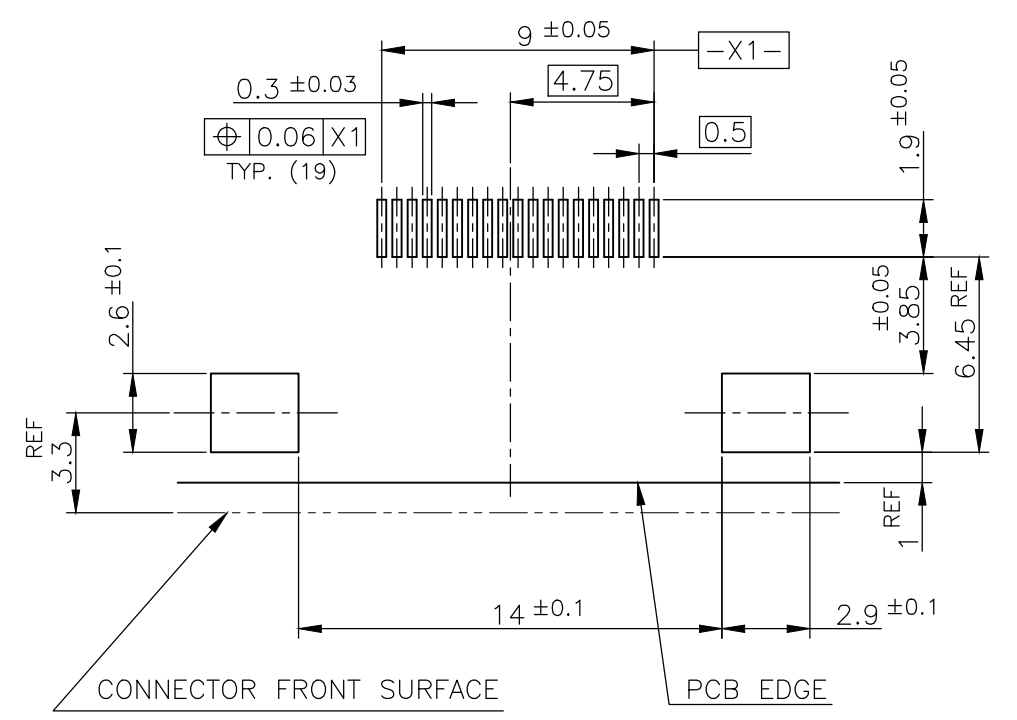
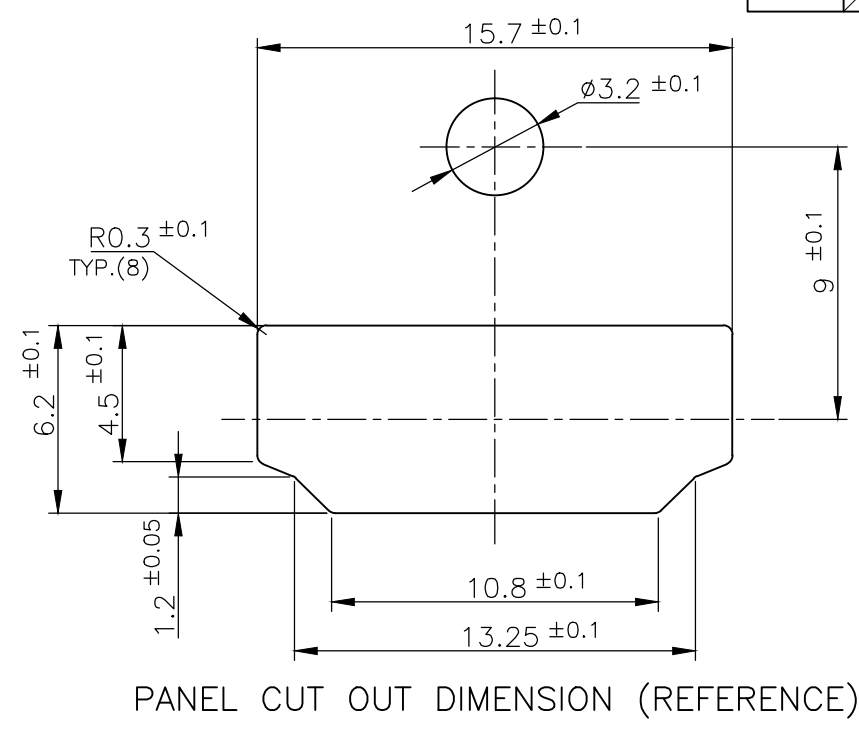
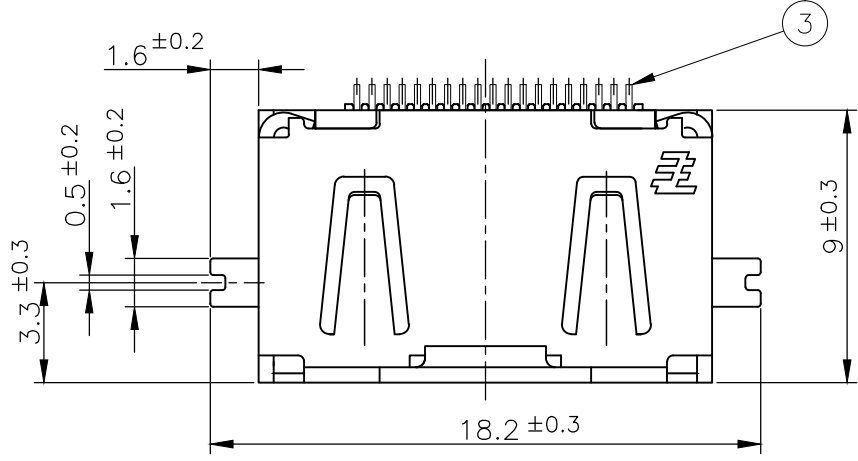

CONNECTOR: WITH FLANGE FULL SMT TYPE

BRASS	CONTACT	3
PHOSPHOR BRONZE	SHELL	2
GLASS FILLED LCP UL94V-0, BLACK COLOR	HOUSING	1
MATERIAL	DESCRIPTION	ITEM

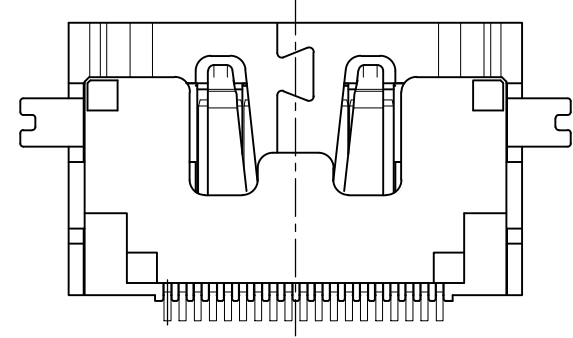

THIS DRAWING IS A CONTROLLED DOCUMENT.		DWN	TE Connectivity NAME 名称 HDMI 19 POS RECEPTACLE ASSY SMT SHORT TYPE				
DIMENSIONS: 单位: 耗 mm		CHK					
TOLERANCES UNLESS OTHERWISE SPECIFIED: 一般公差		APVD					
0 PLC ± 1 PLC ± 2 PLC ± 3 PLC ± 4 PLC ± ANGLES ±		PRODUCT SPEC 製品規格					
MATERIAL 材料	FINISH 仕上	WEIGHT	APPLICATION SPEC 取付適用規格	SIZE	CAGE CODE	DRAWING NO 番号	RESTRICTED TO
CUSTOMER DRAWING			SCALE 尺度 4:1	SHEET 5 OF 12	REV S	A3 00779 C-1903015	

THIS DRAWING IS UNPUBLISHED. RELEASED FOR PUBLICATION SEP, 2005.
 © COPYRIGHT 2005 By - ALL RIGHTS RESERVED.

LOC		DIST		REVISIONS		
				變更	DATE	DWN
P	LTR	DESCRIPTION			APVD	
		SEE SHEET 1				

1903015-1, 2-1903015-2, 5-1903015-1
 5-1903015-5, 7-1903015-1; AS SHOWN

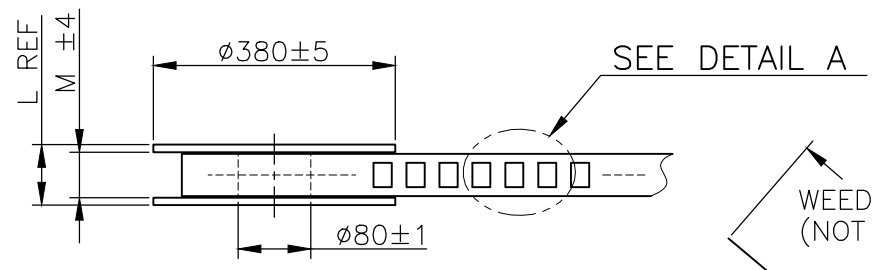
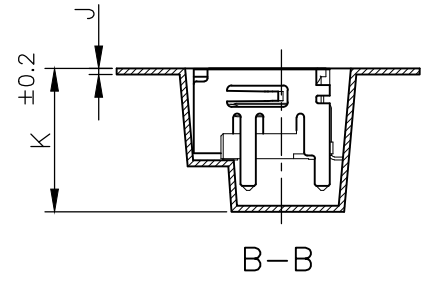
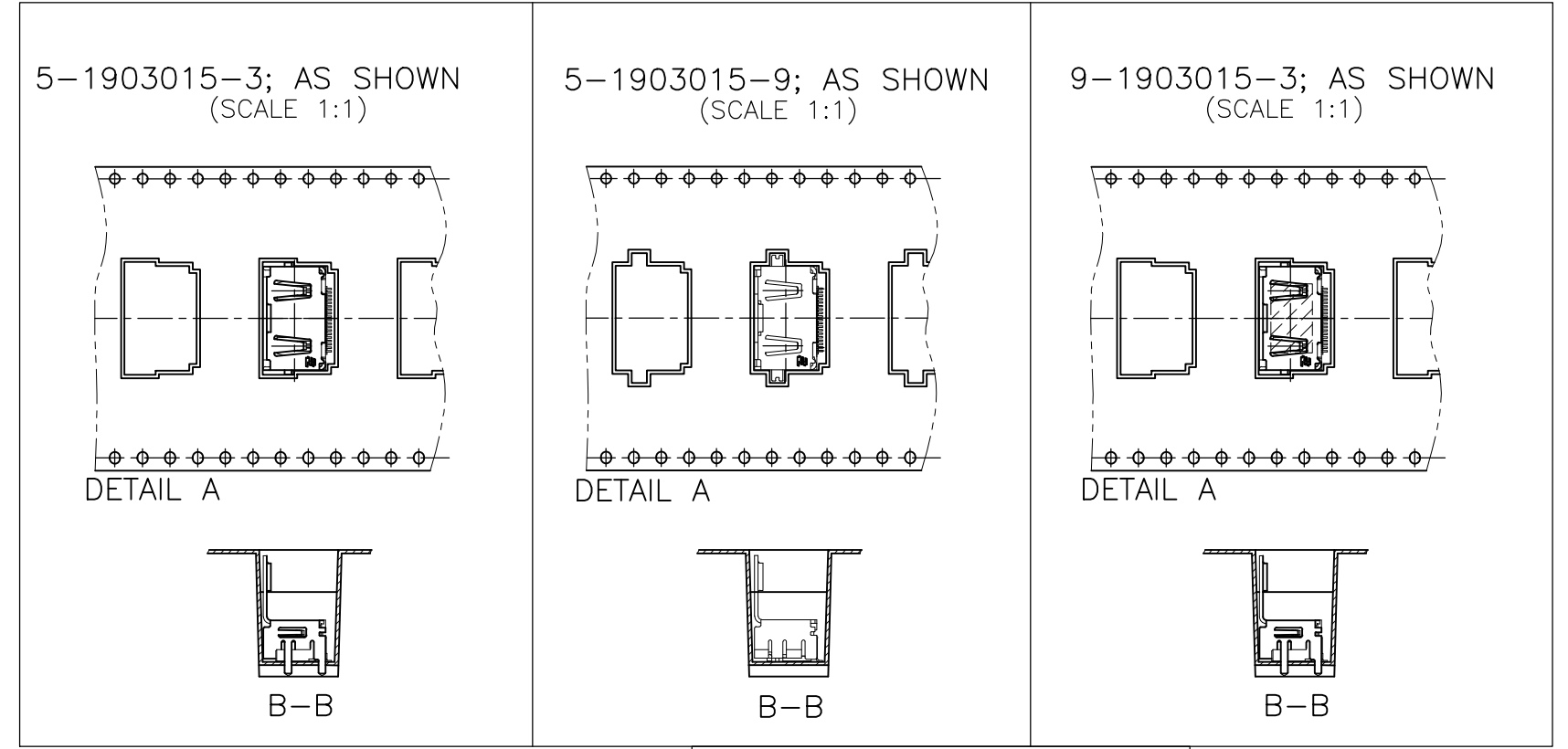
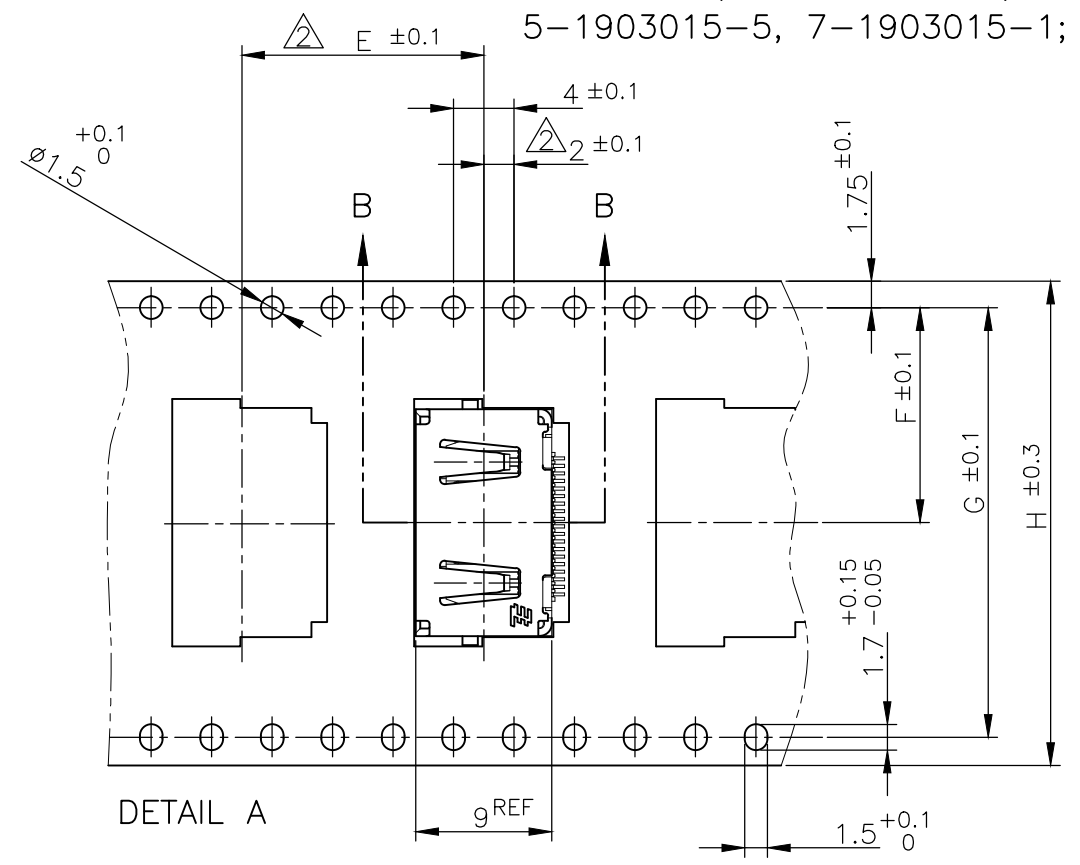

WEEDING THE COVER TAPE: 300 MIN (NOT INCLUDE EMPTINESS POCKET)
 PELLING ANGLE: 165°~180°
 PEELING STRENGTH: 0.1~0.7N (300mm/min.)

△ LABEL DESCRIPTION
 TYCO P/N: *-1903015-*
 QTY: * pcs
 D/C: MADE IN CHINA

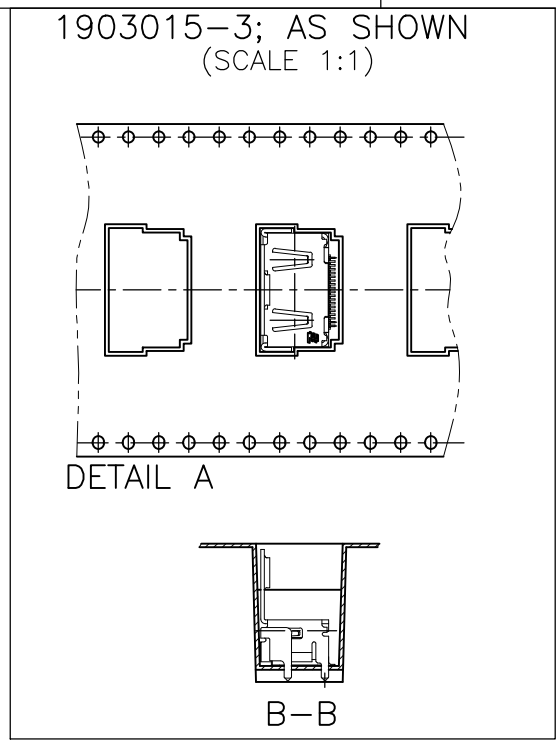

PET	COVER TAPE
PS	CARRIER TAPE
PLASTIC	REEL
MATERIAL	DESCRIPTION

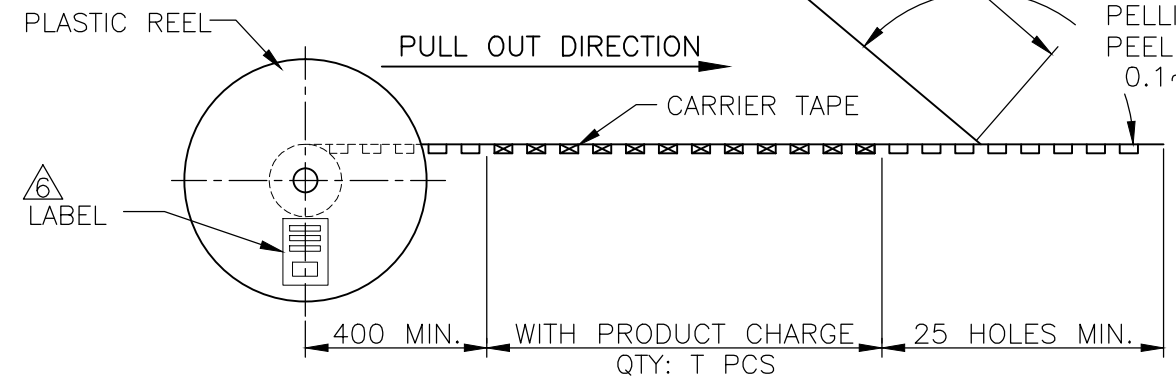

THIS DRAWING IS A CONTROLLED DOCUMENT.		DWN	TE Connectivity NAME 名称 HDMI 19 POS RECEPTACLE ASSY SMT SHORT TYPE			
DIMENSIONS: 單位: 耗 mm		CHK				PRODUCT SPEC 製品規格
TOLERANCES UNLESS OTHERWISE SPECIFIED: 一般公差		APVD				APPLICATION SPEC 取付適用規格
0 PLC ± 1 PLC ± 2 PLC ± 3 PLC ± 4 PLC ± ANGLES ±		WEIGHT				SIZE A3
MATERIAL 材料	FINISH 仕上	CUSTOMER DRAWING	CAGE CODE 00779	DRAWING NO 番号 C-1903015	RESTRICTED TO	
			SCALE 尺度 4:1	SHEET 6 OF 12	REV S	

THIS DRAWING IS UNPUBLISHED. RELEASED FOR PUBLICATION SEP , 2005.
 © COPYRIGHT 2005 By - ALL RIGHTS RESERVED.

LOC	DIST	REVISIONS			DATE	DWN	APVD
		P	LTR	DESCRIPTION			
-	-	-	-	SEE SHEET 1	-	-	-

1903015-4; AS SHOWN

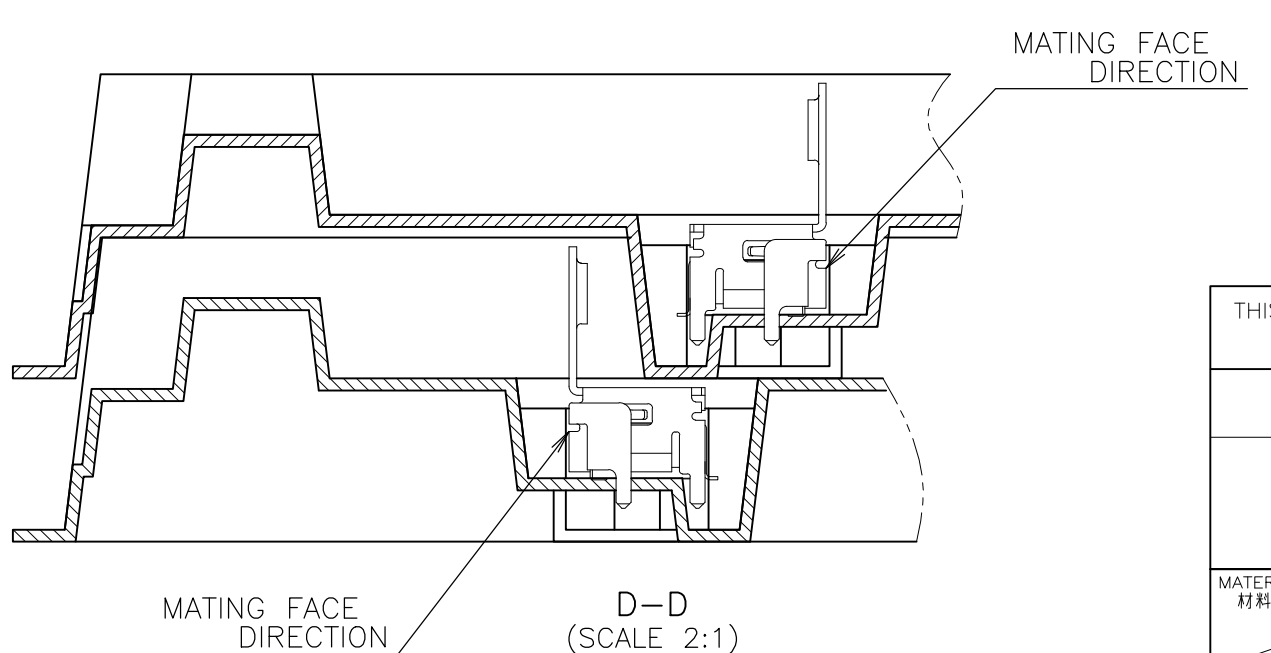
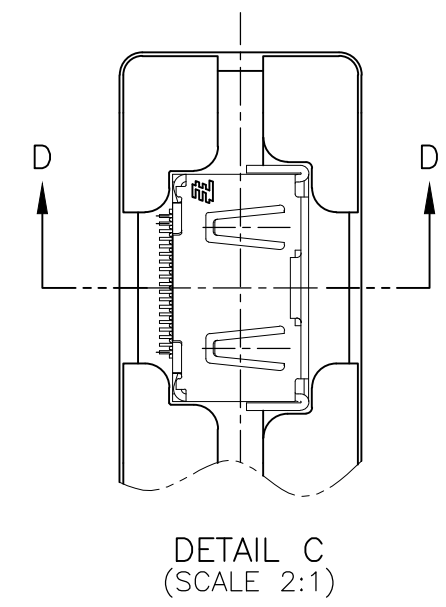
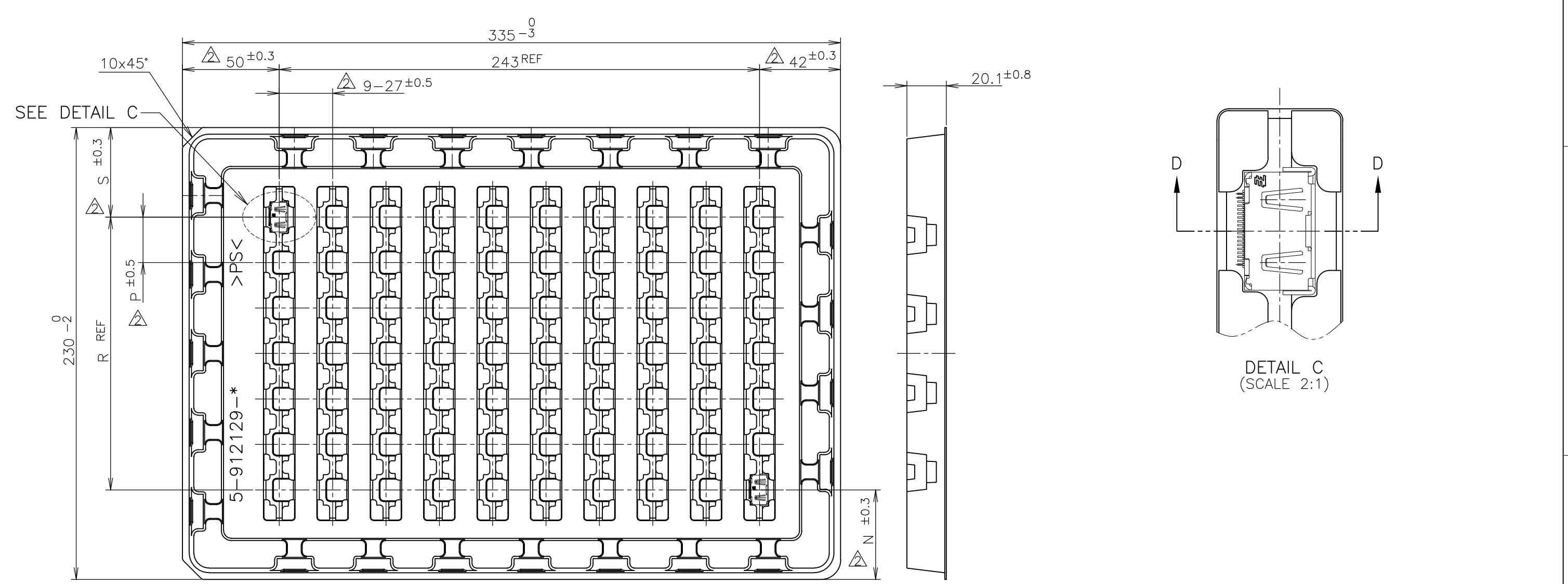

THIS DRAWING IS A CONTROLLED DOCUMENT.		DWN	TE Connectivity NAME 名称 HDMI 19 POS RECEPTACLE ASSY SMT SHORT TYPE			PS	TRAY			
DIMENSIONS: 单位: 耗 mm		CHK				APVD	MATERIAL	DESCRIPTION		
TOLERANCES UNLESS OTHERWISE SPECIFIED: 一般公差		PRODUCT SPEC 製品規格				APPLICATION SPEC 取付適用規格	SIZE	CAGE CODE	DRAWING NO 番号	RESTRICTED TO
0 PLC ± 1 PLC ± 2 PLC ± 3 PLC ± 4 PLC ± ANGLES ± MATERIAL 材料 FINISH 仕上		WEIGHT				A3	00779	C-1903015		
CUSTOMER DRAWING			SCALE 尺度 4:1	SHEET 8 OF 12	REV S					

THIS DRAWING IS UNPUBLISHED. RELEASED FOR PUBLICATION SEP ,2005.
 © COPYRIGHT 2005 By - ALL RIGHTS RESERVED.

LOC		DIST		REVISIONS			DATE	DWN	APVD
				变更					
P	LTR	DESCRIPTION							
-	-	SEE SHEET 1			-	-	-	-	

1903015-7, 1903015-8; AS SHOWN

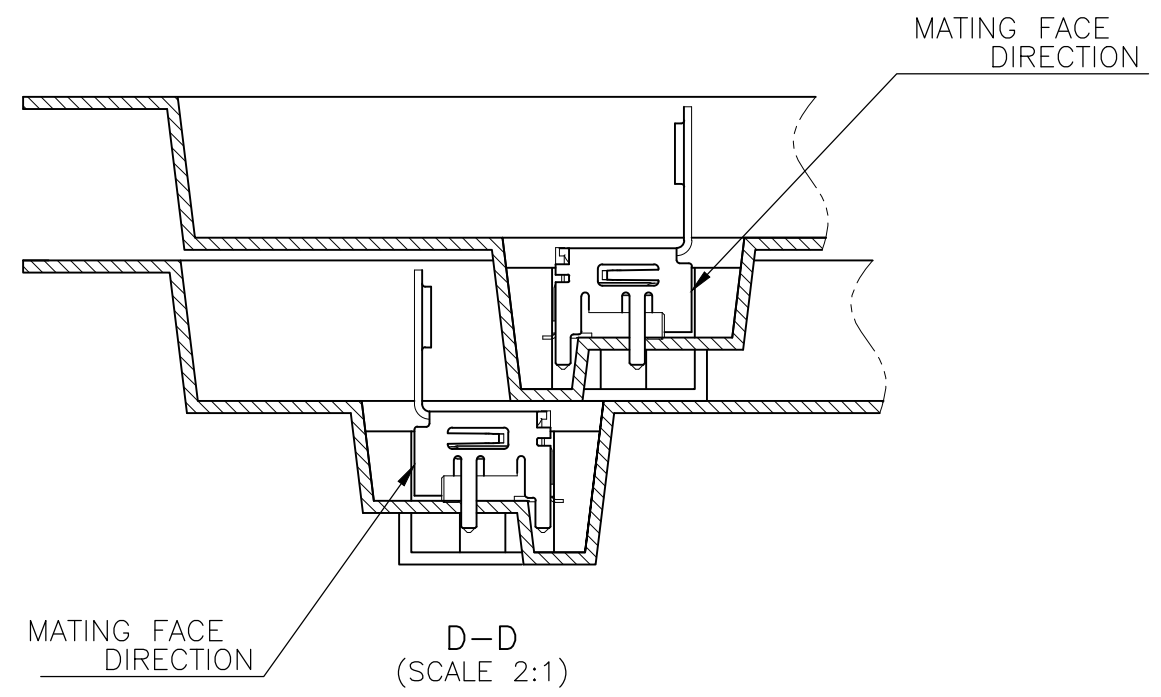
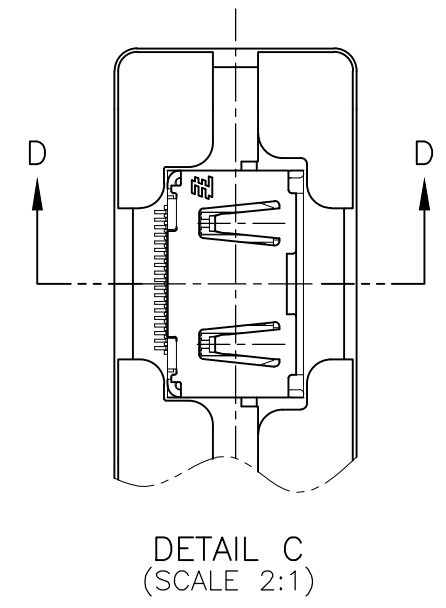
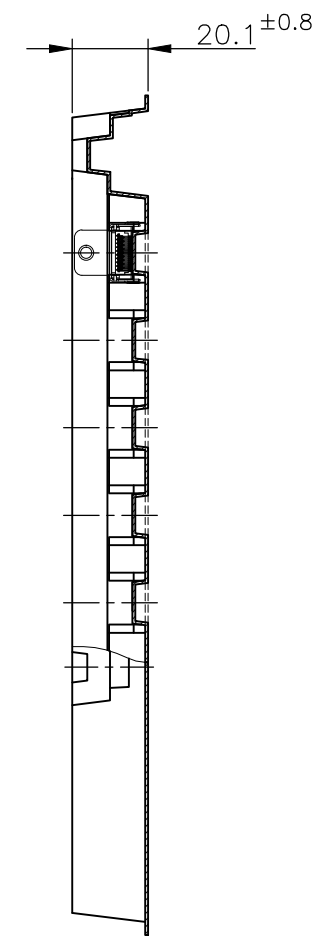
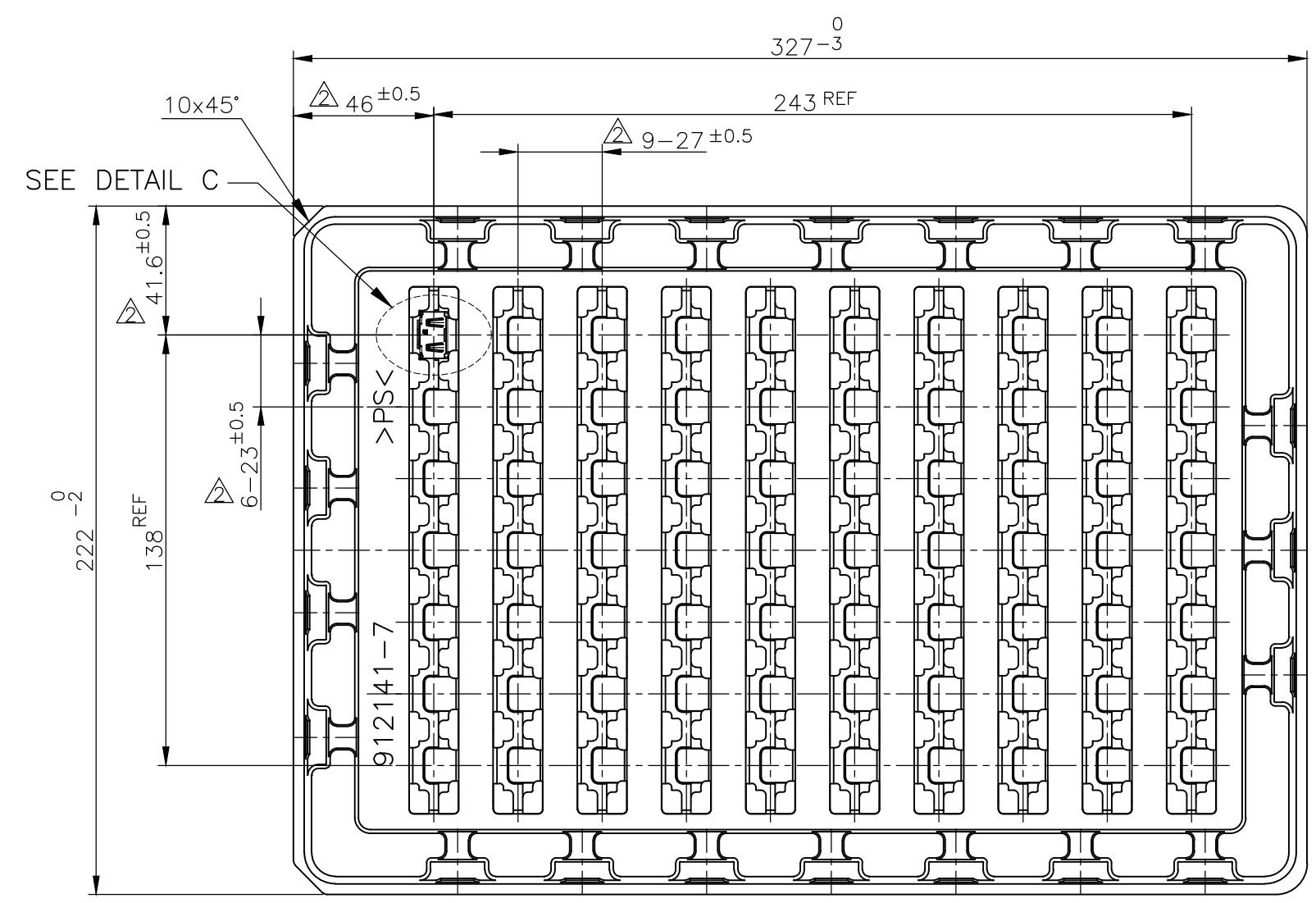

THIS DRAWING IS A CONTROLLED DOCUMENT.		DWN	TE Connectivity NAME 名称 HDMI 19 POS RECEPTACLE ASSY SMT SHORT TYPE			RESTRICTED TO			
DIMENSIONS: 单位: 耗 mm		CHK				SIZE	CAGE CODE	DRAWING NO 番号	-
TOLERANCES UNLESS OTHERWISE SPECIFIED: 一般公差		APVD				A3	00779	C-1903015	
0 PLC ± 1 PLC ± 2 PLC ± 3 PLC ± 4 PLC ± ANGLES ± FINISH 仕上		PRODUCT SPEC 製品規格				SCALE 尺度 4:1			SHEET 9 OF 12
MATERIAL 材料		APPLICATION SPEC 取付適用規格	CUSTOMER DRAWING			REV S			

THIS DRAWING IS UNPUBLISHED.

RELEASED FOR PUBLICATION

SEP, 2005.

© COPYRIGHT 2005 By -

ALL RIGHTS RESERVED.

LOC	DIST
-	-

REVISIONS		DATE	DWN	APVD
変更				
P	LTR	DESCRIPTION		
-	-	SEE SHEET 1	-	-

8-1903015-4; AS SHOWN

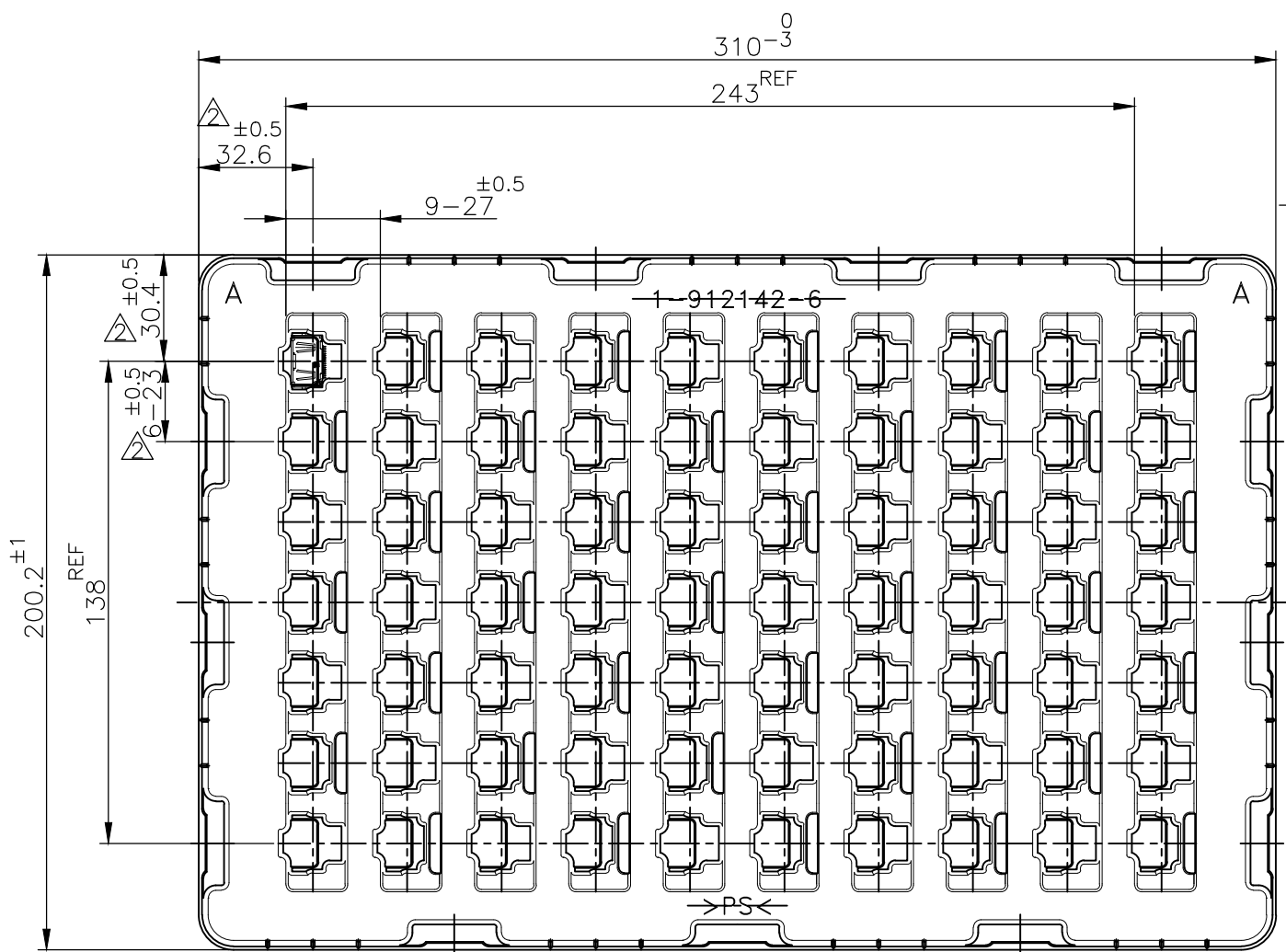

TRAY A

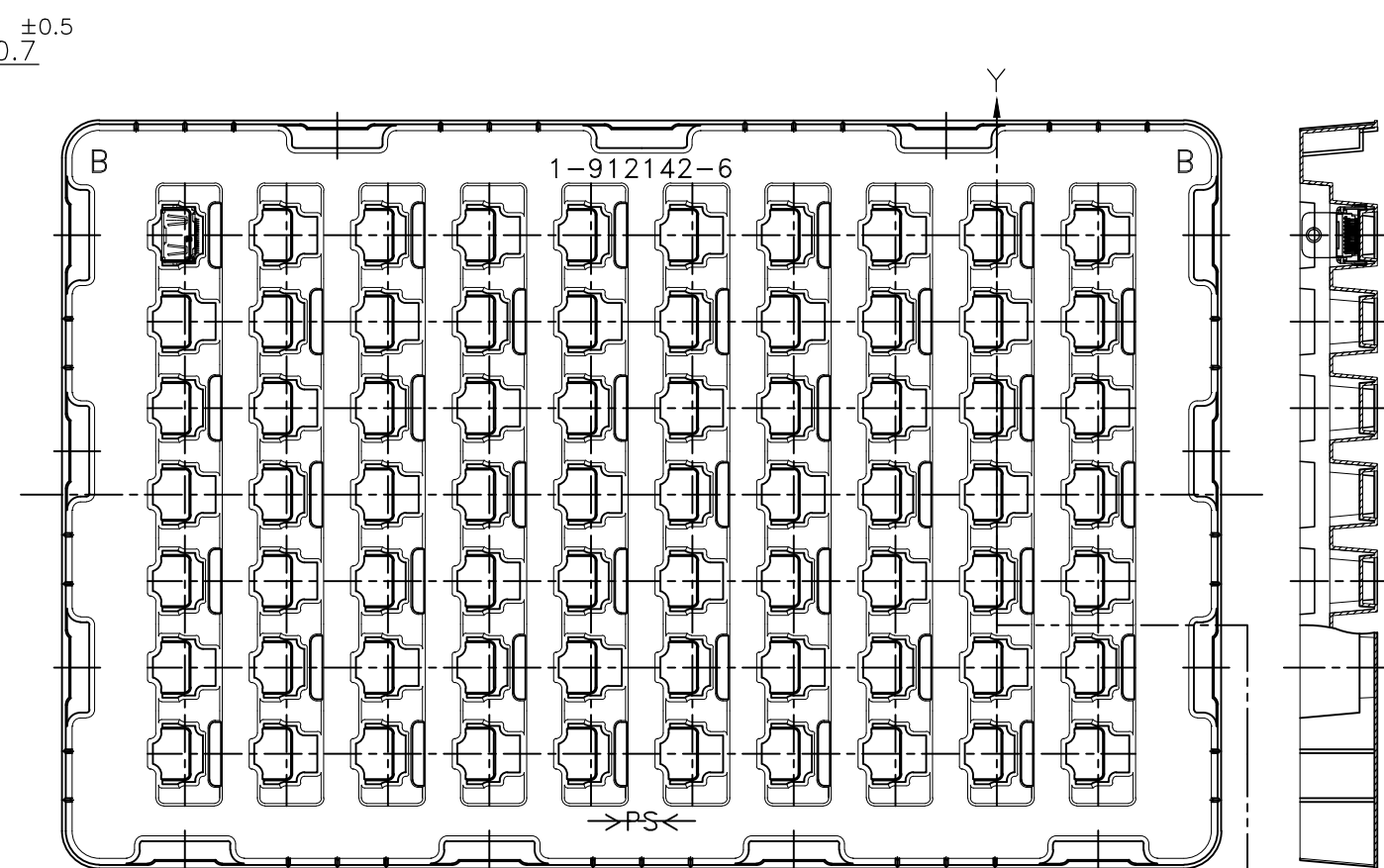

TRAY B

TRAY B (EMPTY)

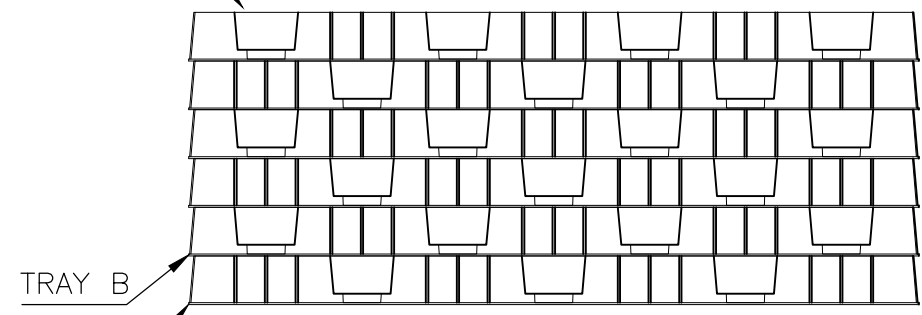

TRAY B

TRAY A

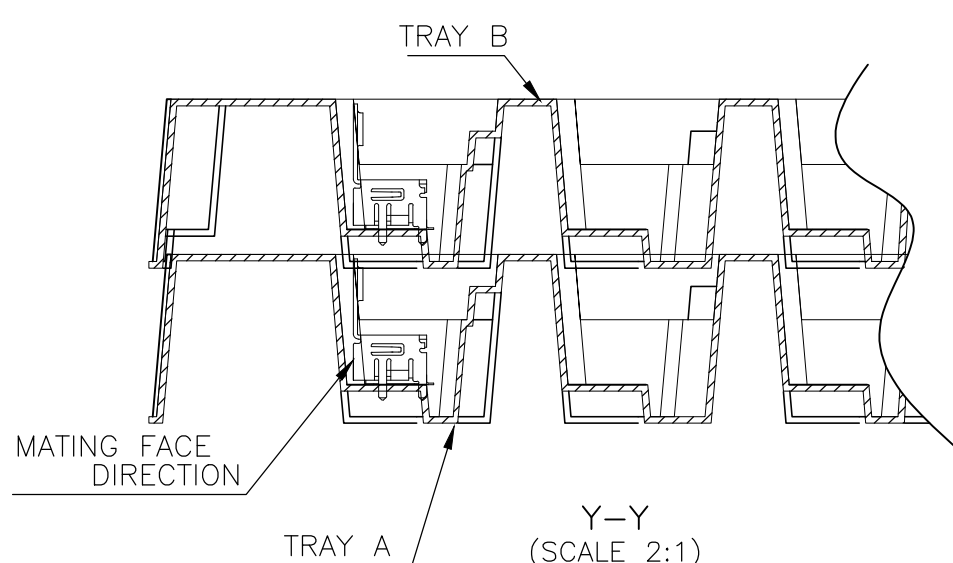

Y-Y (SCALE 2:1)

PS	TRAY
MATERIAL	DESCRIPTION

THIS DRAWING IS A CONTROLLED DOCUMENT.		DWN	STE TE Connectivity	
DIMENSIONS: 單位: 耗 mm		CHK		
TOLERANCES UNLESS OTHERWISE SPECIFIED: 一般公差		APVD	NAME 名称	
0 PLC ±		PRODUCT SPEC 製品規格	HDMI 19 POS RECEPTACLE ASSY	
1 PLC ±		APPLICATION SPEC 取付適用規格	SMT SHORT TYPE	
2 PLC ±		WEIGHT	SIZE	CAGE CODE
3 PLC ±		CUSTOMER DRAWING	A3	00779
4 PLC ±			DRAWING NO 番号	G-1903015
ANGLES ±		RESTRICTED TO	-	
FINISH 仕上		SCALE 尺度	4:1	SHEET 10 OF 12
MATERIAL 材料		REV	S	

THIS DRAWING IS UNPUBLISHED. RELEASED FOR PUBLICATION SEP ,2005.
 © COPYRIGHT 2005 By - ALL RIGHTS RESERVED.

LOC		DIST		REVISIONS 変更			DATE	DWN	APVD
P	LTR	DESCRIPTION							
-	-	SEE SHEET 1			-	-	-	-	

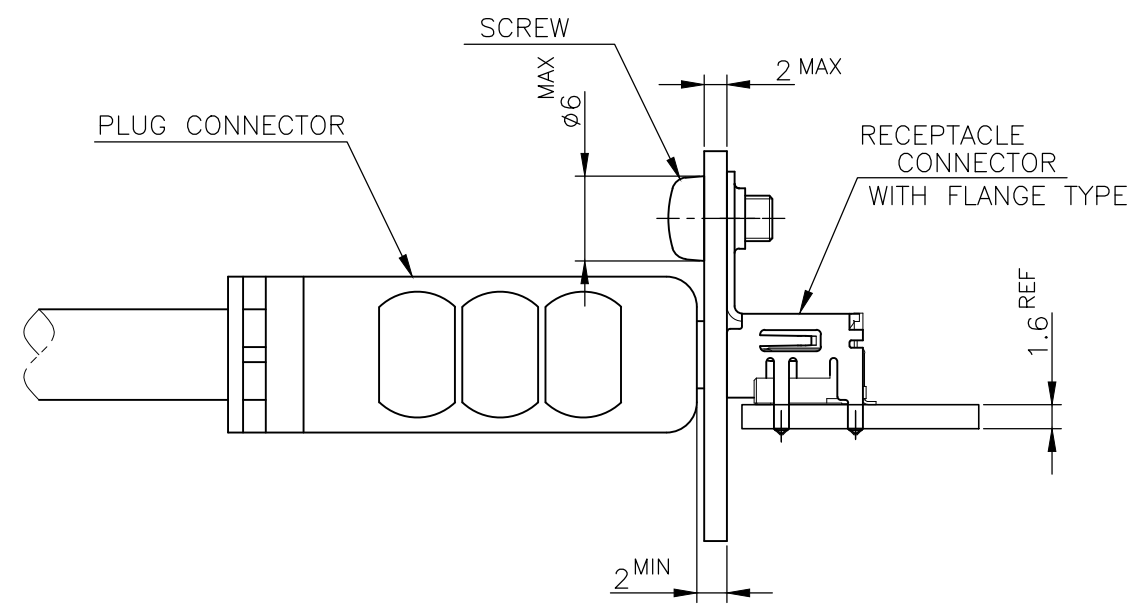
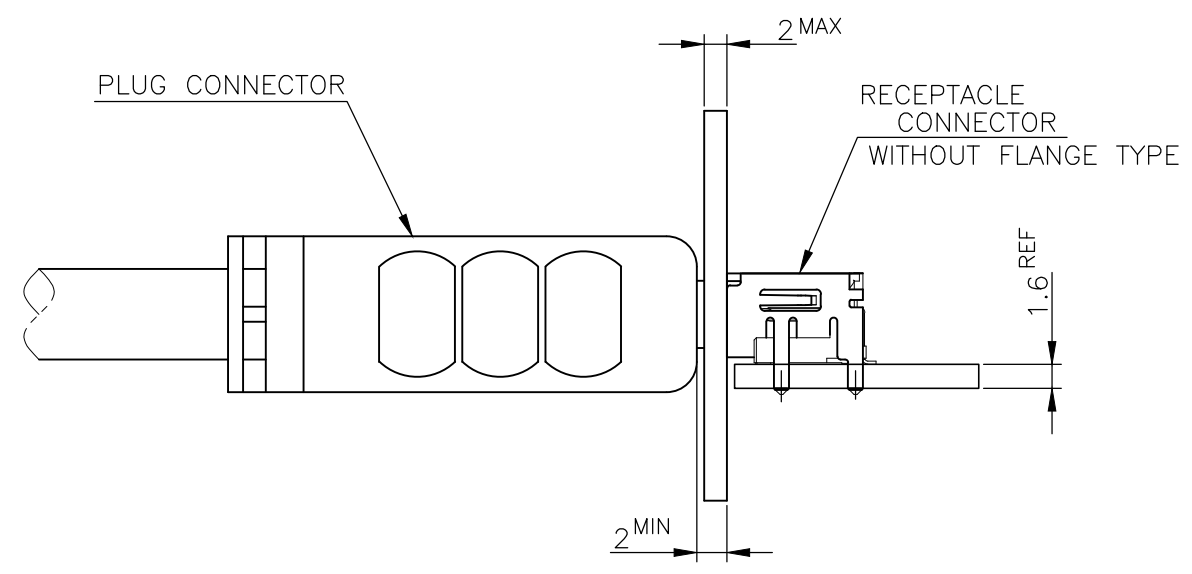

MATING CONDITION (REFERENCE)
(SCALE 2:1)

THIS DRAWING IS A CONTROLLED DOCUMENT.		DWN		STE TE Connectivity	
DIMENSIONS: 單位: 耗 mm		CHK			
		APVD		NAME 名稱	
		PRODUCT SPEC 製品規格		HDMI 19 POS RECEPTACLE ASSY SMT SHORT TYPE	
MATERIAL 材料		FINISH 仕上		APPLICATION SPEC 取付適用規格	
WEIGHT		SIZE		CAGE CODE	
CUSTOMER DRAWING		A3		00779	
SCALE 尺度 4:1		DRAWING NO 番号		RESTRICTED TO	
SHEET 11 OF 12		G-1903015		-	
REV S					

THIS DRAWING IS UNPUBLISHED. RELEASED FOR PUBLICATION SEP, 2005.
 ALL RIGHTS RESERVED.

LOC	DIST	P	LTR	REV	DATE	DWN	APVD
-	-	-	-	1	-	-	-

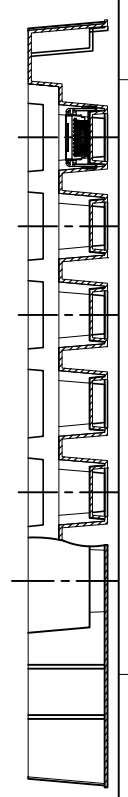
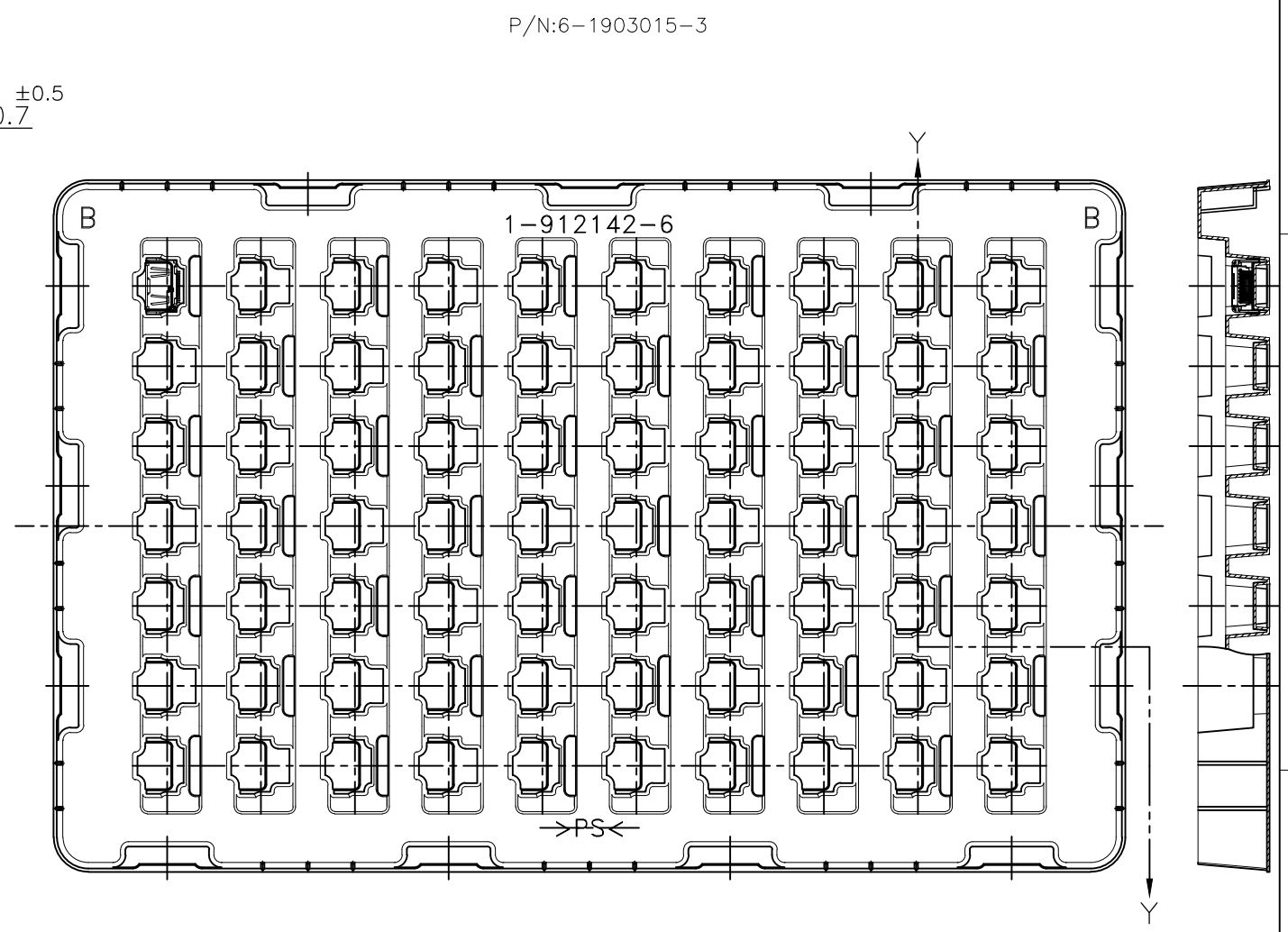
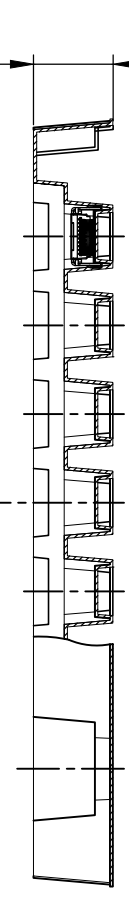
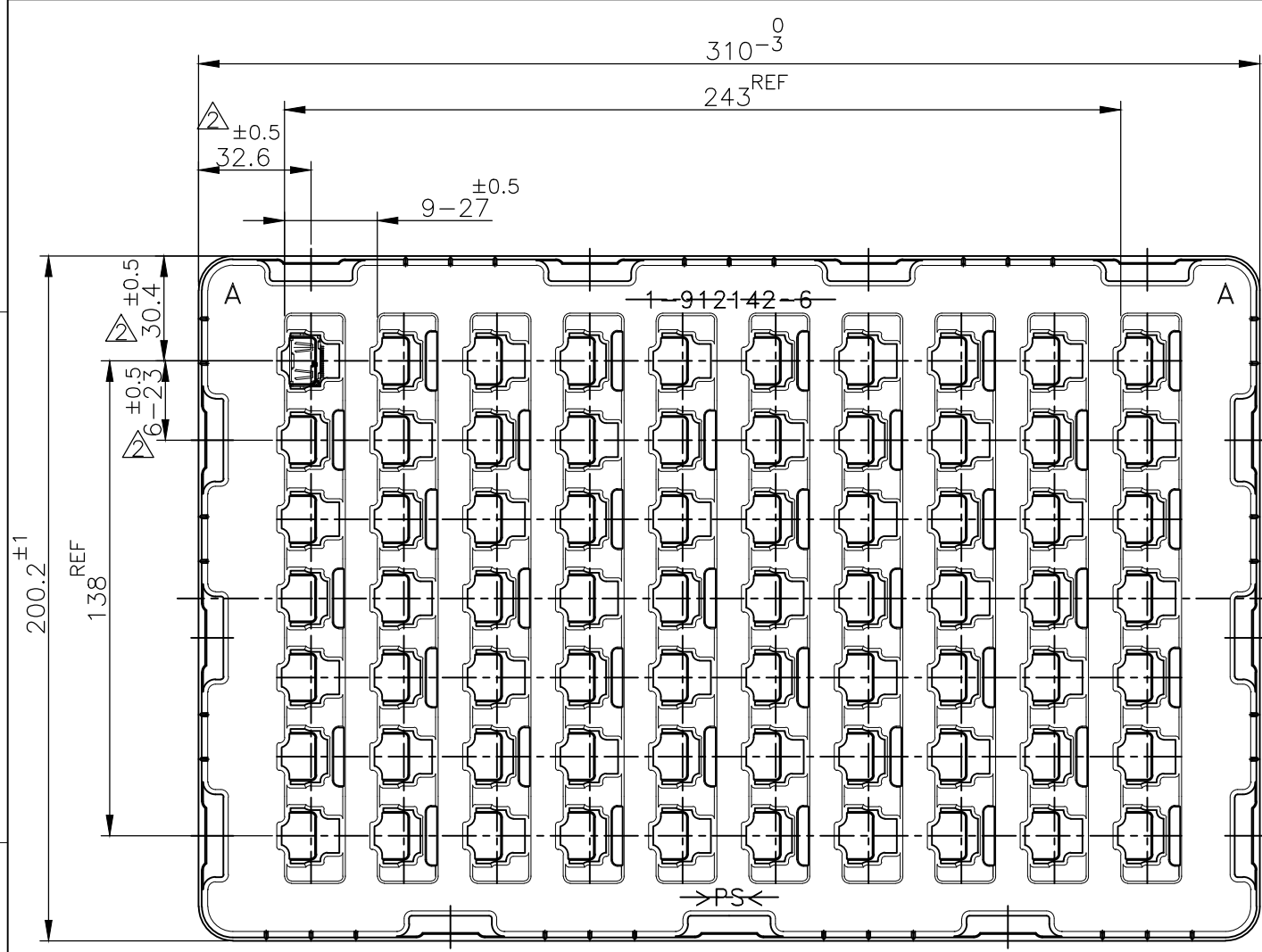

P/N:6-1903015-3

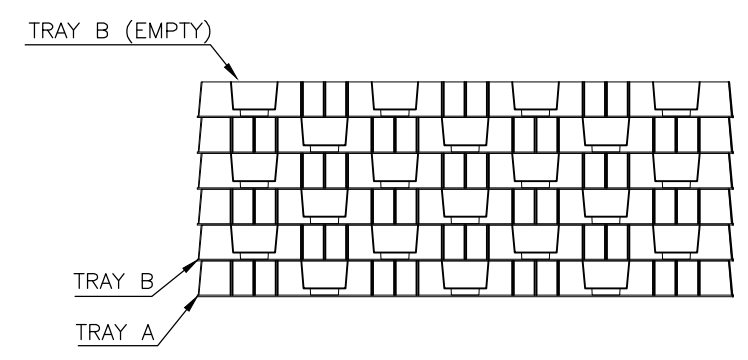
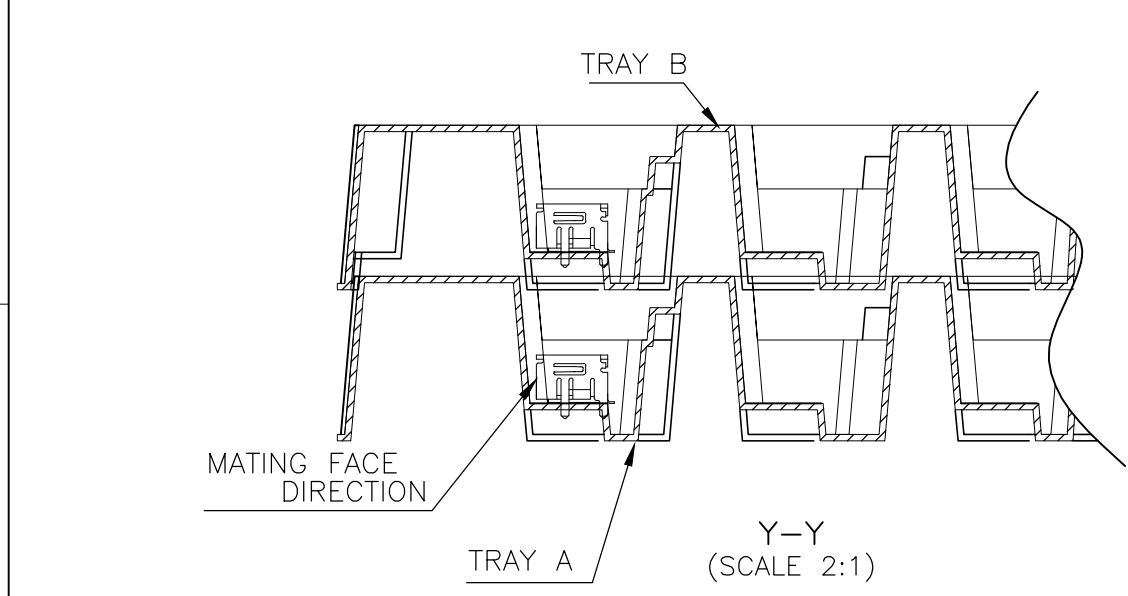

PS	TRAY
MATERIAL	DESCRIPTION

THIS DRAWING IS A CONTROLLED DOCUMENT.		DWN	TE Connectivity NAME 名称 HDMI 19 POS RECEPTACLE ASSY SMT SHORT TYPE			RESTRICTED TO		
DIMENSIONS: 單位: 耗 mm		CHK				SIZE	CAGE CODE	DRAWING NO 番号
TOLERANCES UNLESS OTHERWISE SPECIFIED: 一般公差		APVD				A3	00779	G-1903015
0 PLC ± 1 PLC ± 2 PLC ± 3 PLC ± 4 PLC ANGLS ±		PRODUCT SPEC 製品規格				SCALE 尺度 4:1		
MATERIAL 材料		FINISH 仕上	APPLICATION SPEC 取付適用規格			SHEET 12 OF 12		
WEIGHT			CUSTOMER DRAWING			REV S		

单击下面可查看定价，库存，交付和生命周期等信息

[>>TE Connectivity\(泰科\)](#)