

- ① HOUSING: NYLON OR POLYESTER, FLAME RETARDANT 94V-0 RATED, GLASS FILLED, BLACK.
SHELLS: CARBON STEEL.
CONTACTS: BRASS.
BOARDLOCKS: COPPER ALLOY.
EYELETS: BRASS.
- ② SHELLS: 2.54μm[.000100] MIN TIN OVER 1.27μm[.000050] MIN COPPER.
EYELETS: 5.08μm[.000200] MIN TIN OVER COPPER FLASH.
CONTACTS: SEE TABLE.
BOARDLOCKS: SEE TABLE.
INSERTS: CLEAR CHROMATE.
SCREWLOCKS: CLEAR CHROMATE.
- ③ GOLD FLASH ON THE MATING SURFACES, 2.54μm[.000100] MIN TIN OR TIN-LEAD PLATE ON THE SOLDER END, 1.27μm[.000050] MIN NICKEL UNDERPLATE ON THE ENTIRE CONTACT.
- ④ 0.76μm[.000030] MIN GOLD PLATE ON THE MATING SURFACES, 2.54μm[.000100] MIN TIN OR TIN-LEAD PLATE ON THE SOLDER END, 1.27μm[.000050] MIN NICKEL UNDERPLATE ON THE ENTIRE CONTACT
-OR-
GOLD FLASH OVER PALLADIUM-NICKEL PLATE, 0.76μm[.000030] MIN TOTAL ON THE MATING SURFACES, 2.54μm[.000100] MIN TIN OR TIN-LEAD PLATE ON THE SOLDER END, 1.27μm[.000050] MIN NICKEL UNDERPLATE ON THE ENTIRE CONTACT.
- ⑤ 5.08μm[.000200] MIN TIN-LEAD OVER 1.27μm [.000050] MIN NICKEL.
- ⑥ 5.08μm[.000200] MIN TIN OVER 1.27μm [.000050] MIN NICKEL.
- ⑦ DIMENSION APPLIES FROM CENTER OF CONTACTS.
- ⑧ SUPERSEDED BY 747842-2.
- ⑨ OBSOLETE PARTS: OBSOLETE CIS STREAMLINING PER D.RENAUD/D.SINISI.

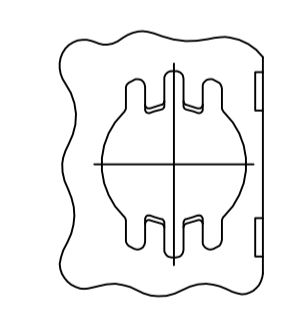

FOR -5 AND -6 ONLY
DETAIL F
2 PLC

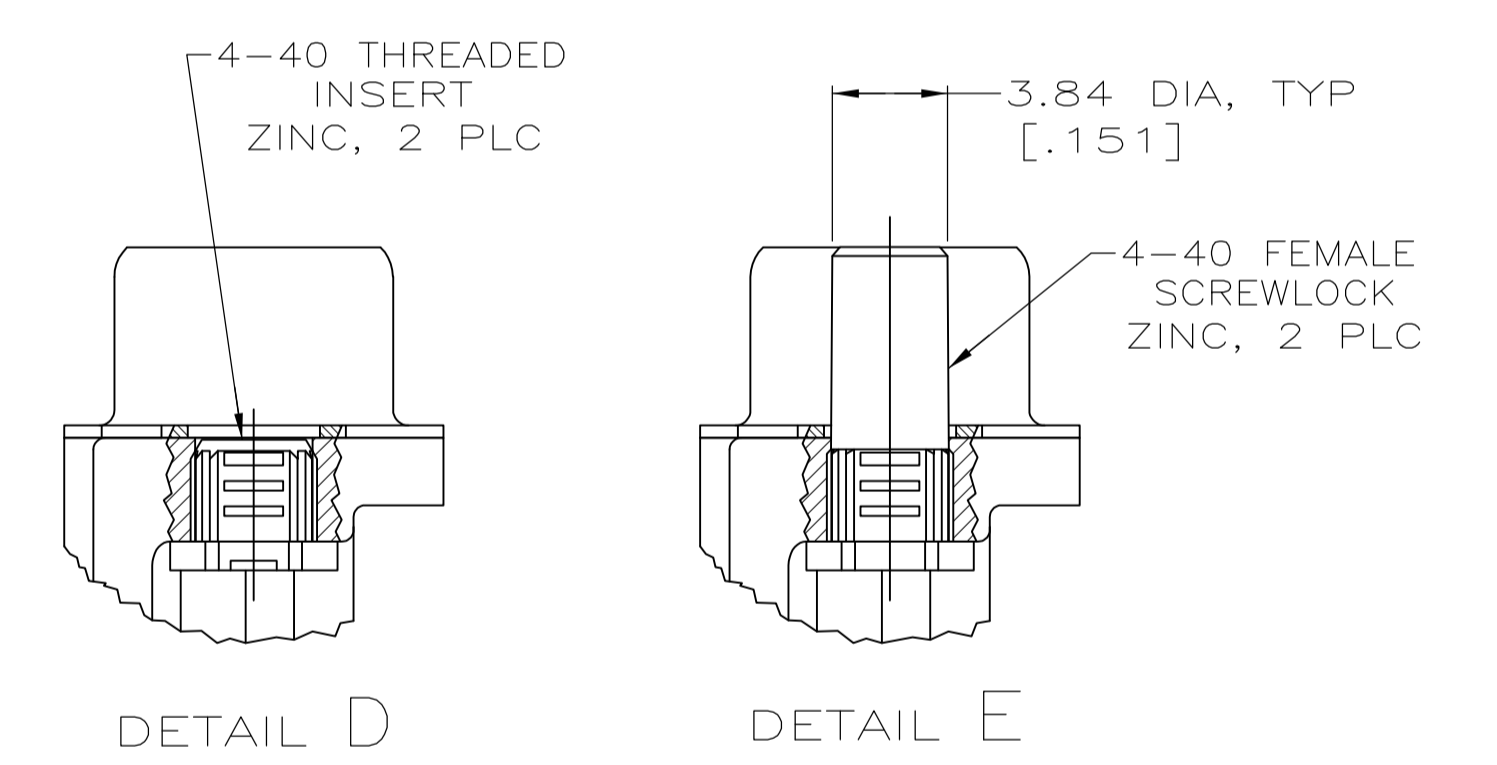
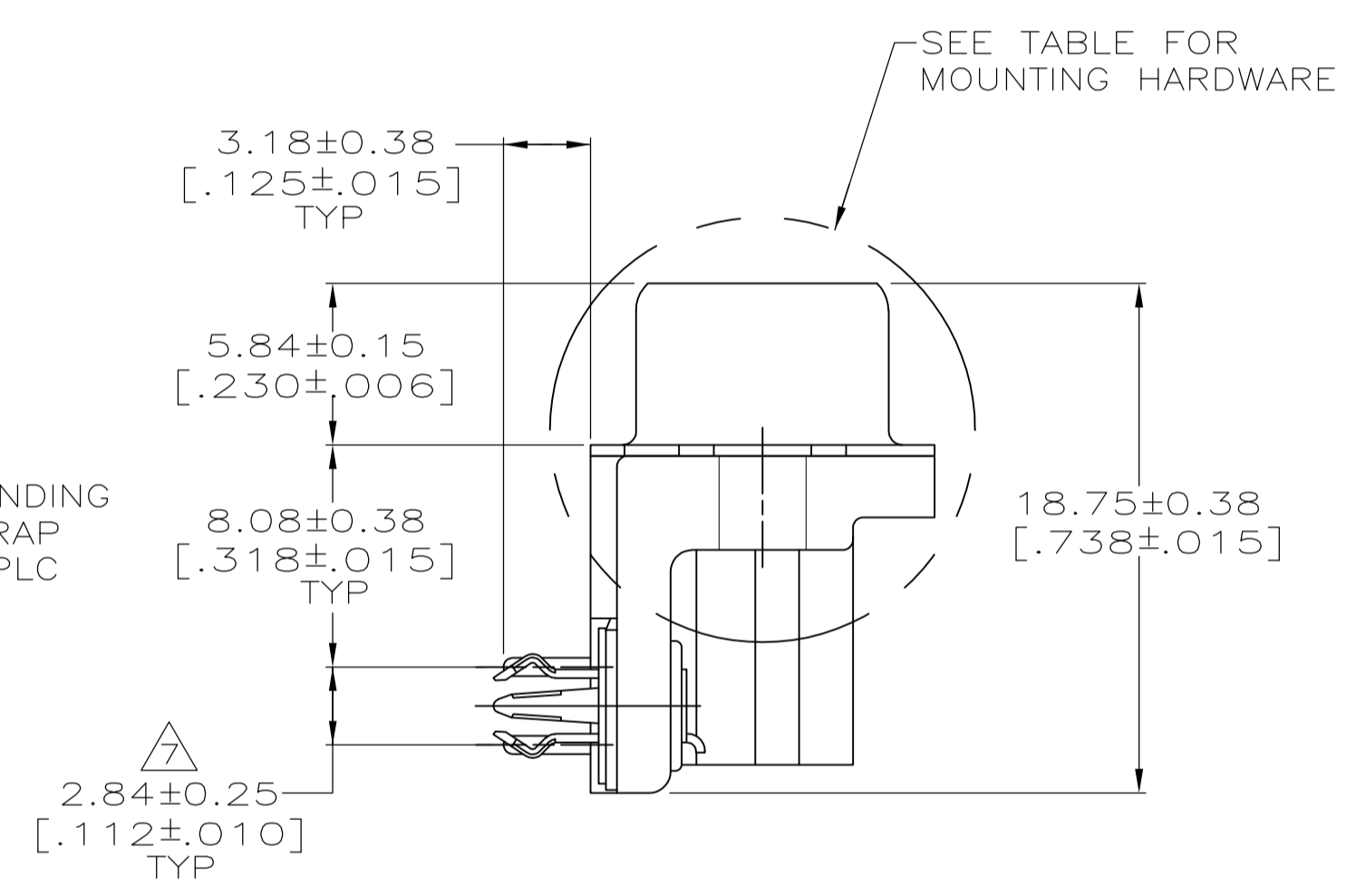
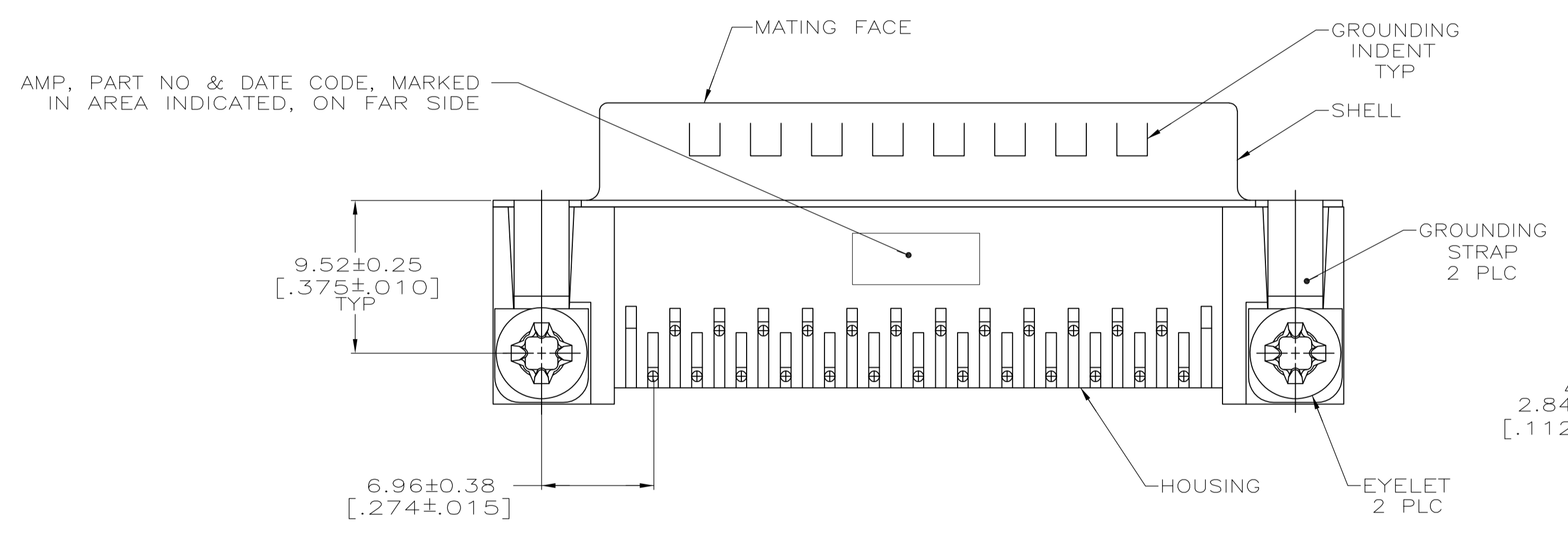
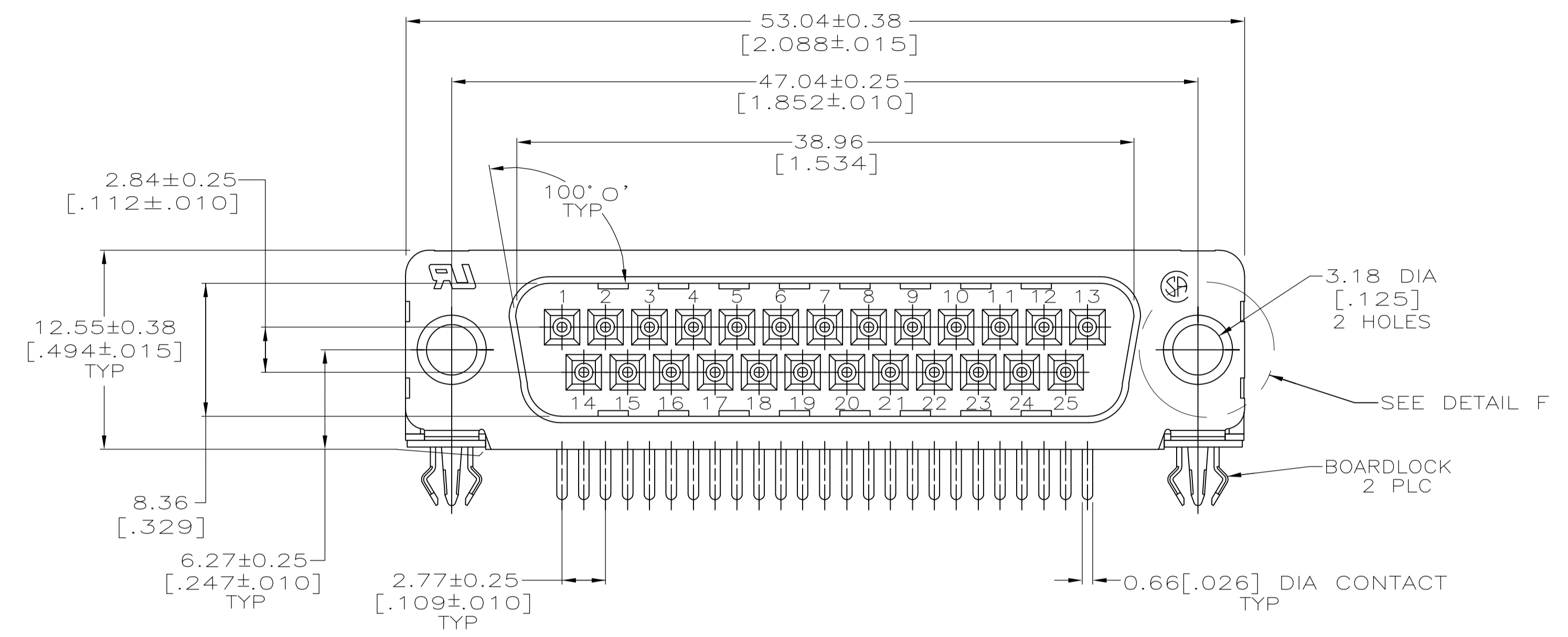
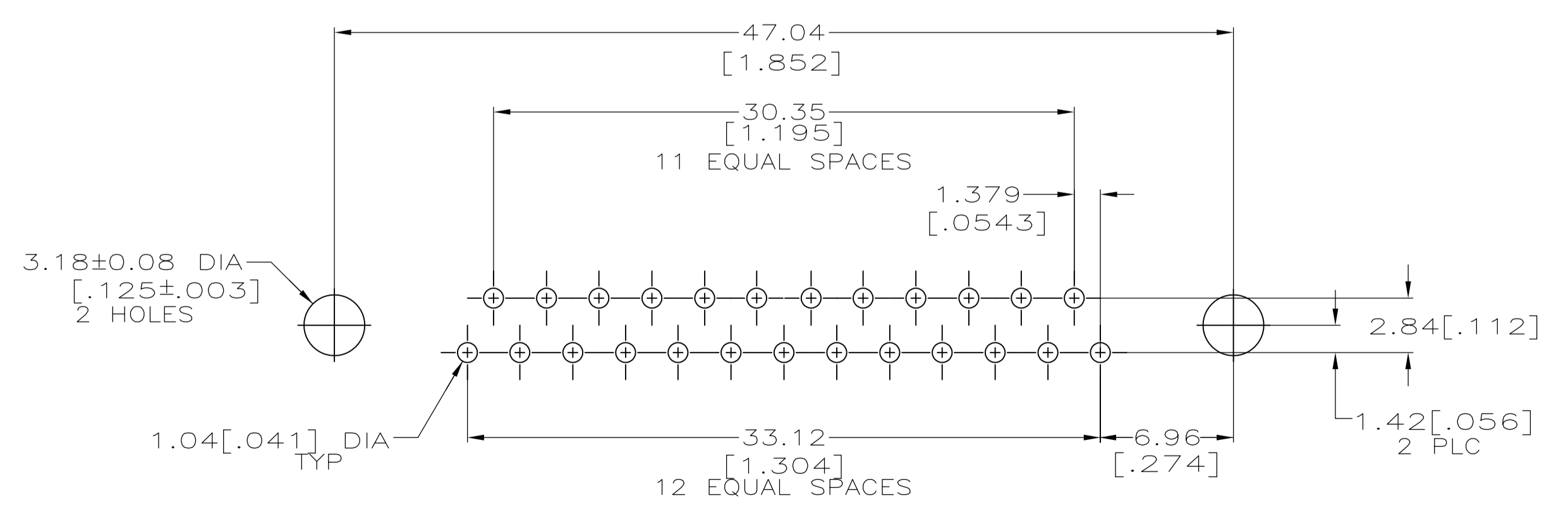

RECOMMENDED P.C. BOARD MOUNTING DIMENSIONS
P.C. BOARD THICKNESS: 1.57[.062]

SEE DETAIL E	⑥	④	OBSOLETE	6-747842-9
SEE DETAIL D	⑥	④	ACTIVE	6-747842-8
SEE DETAIL E	⑤	④	ACTIVE	747842-6
SEE DETAIL D	⑤	④	ACTIVE	747842-4
-	⑤	④	-	747842-3
-	⑤	④	-	747842-2
-	⑤	④	-	747842-1
MOUNTING HARDWARE	BOARDLOCK FINISH	CONTACT FINISH	PART STATUS	PART NO

THIS DRAWING IS A CONTROLLED DOCUMENT. DIMENSIONING AND TOLERANCING PER ASME Y14.5M-2009

DIMENSIONS: mm [INCHES]	TOLERANCES UNLESS OTHERWISE SPECIFIED:	DWG: W.G. LENKER	10-5-89
0 PLC ± -	1 PLC ± -	CHK: R. STONE	2-5-90
2 PLC ± 0.13[.005]	3 PLC ± -	APVD: -	-
4 PLC ± -	ANGLES ± 2°	NAME: -	-

STE TE Connectivity

PLUG ASSEMBLY, SIZE 3, 25 POSITION, RIGHT ANGLE, FRONT METAL SHELL, .318 SERIES, BOARDLOCKS, AMPLIMITE HD-20

108-40025

114-40010

00779C=747842

CUSTOMER DRAWING SCALE 4:1 SHEET 1 OF 1 REV U

单击下面可查看定价，库存，交付和生命周期等信息

[>>TE Connectivity\(泰科\)](#)