

THIS DRAWING IS UNPUBLISHED. RELEASED FOR PUBLICATION
 © COPYRIGHT - By - ALL RIGHTS RESERVED.

REVISIONS				
P	LTR	DESCRIPTION	DATE	APVD
E		REV PER ECO 18-017445	1-7-19	CT DM

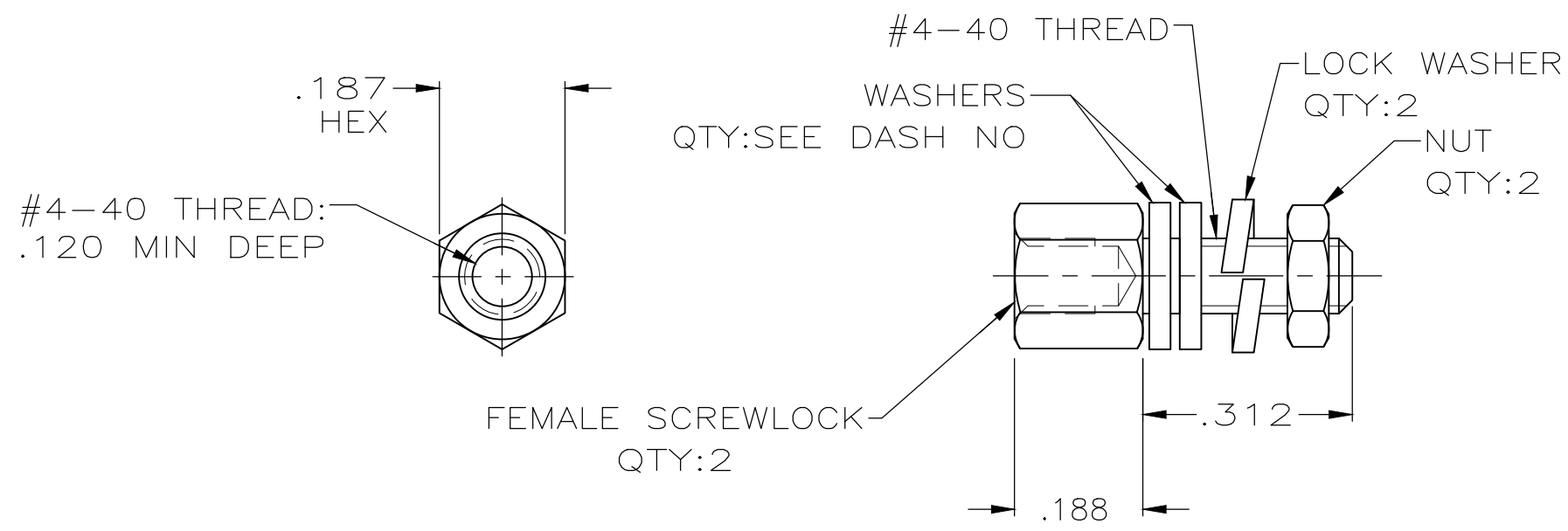

- 1 ZINC PLATED .000200-000400 THICK YELLOW CHROMATE COATING.
- 2 ZINC PLATED .000200-000400 THICK CLEAR CHROMATE COATING.
- 3. PARTS PACKAGED UNASSEMBLED.
- 4 PARTS PACKED AS A UNIT KIT.
- 5 PARTS INDIVIDUALLY BULK PACKED & SHIPPED AS A UNIT PACKAGE.
- 6. IDENTIFIED BY MIL SPEC PART NUMBER M24308/26-1Z FOR -8 ONLY & TE PART NUMBER (FOR ALL DASH NUMBERS).
- 7 CHROMATE FINISH PER ASTM B633 EXCEPT FOR USE OF TRIVALENT CHROMIUM TO MEET RoHS REGULATIONS.

OBSOLETE				
	4	6	1	5205817-9
	4	6	1/7	5205817-8
	5	4	2	5205817-4
	4	4	2	5205817-3
	5	4	1	5205817-2
	4	4	1	5205817-1
	PACKAGING	NO OF WASHERS	FINISH	PART NUMBER

THIS DRAWING IS A CONTROLLED DOCUMENT.		DWN S.WAITMAN 27JUN05	TE Connectivity													
DIMENSIONS: INCHES		CHK C.ROHDE 27JUN05				NAME										
TOLERANCES UNLESS OTHERWISE SPECIFIED:		APVD M.WALMSLEY 27JUN05						KIT, SCREWLOCK, FEMALE, AMPLIMITE								
<table border="0"> <tr><td>0 PLC</td><td>± -</td></tr> <tr><td>1 PLC</td><td>± -</td></tr> <tr><td>2 PLC</td><td>± -</td></tr> <tr><td>3 PLC</td><td>± .005</td></tr> <tr><td>4 PLC</td><td>± -</td></tr> <tr><td>ANGLES</td><td>± -</td></tr> </table>		0 PLC				± -	1 PLC			± -	2 PLC	± -	3 PLC	± .005	4 PLC	± -
0 PLC	± -															
1 PLC	± -															
2 PLC	± -															
3 PLC	± .005															
4 PLC	± -															
ANGLES	± -															
MATERIAL COLD ROLLED STEEL		FINISH SEE TABLE	APPLICATION SPEC	SIZE	CAGE CODE	DRAWING NO	RESTRICTED TO									
			WEIGHT 0.000000	A3	00779	C-5205817										
CUSTOMER DRAWING			SCALE 4:1	SHEET 1 OF 1	REV E											

单击下面可查看定价，库存，交付和生命周期等信息

[>>TE Connectivity\(泰科\)](#)