

| REVISIONS | | | | |
|-----------|------|---------------------------|-----------|---------|
| # | DATE | DESCRIPTION | DATE | APP'D |
| A3 | | REVISED PER ECO-13-008133 | 17MAY2013 | DLD DCM |
| A4 | | REVISED PER ECO-17-001034 | 25JAN2017 | DLD DCM |
| A5 | | REVISED PER ECO-17-007766 | 30MAY2017 | DLD DCM |

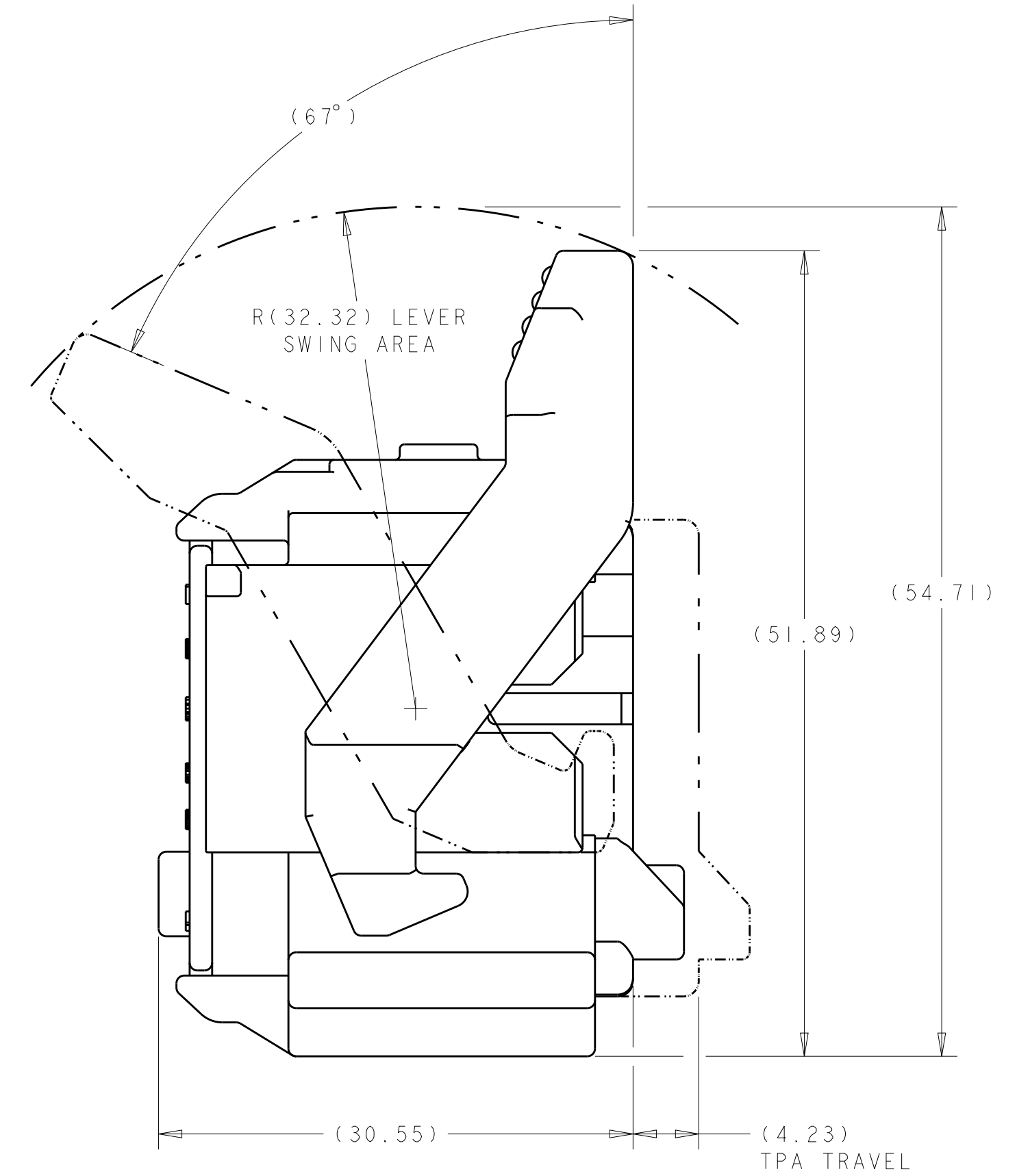

LEVER AND TPA SHOWN IN THEIR LATCHED POSITIONS FOR REFERENCE ONLY

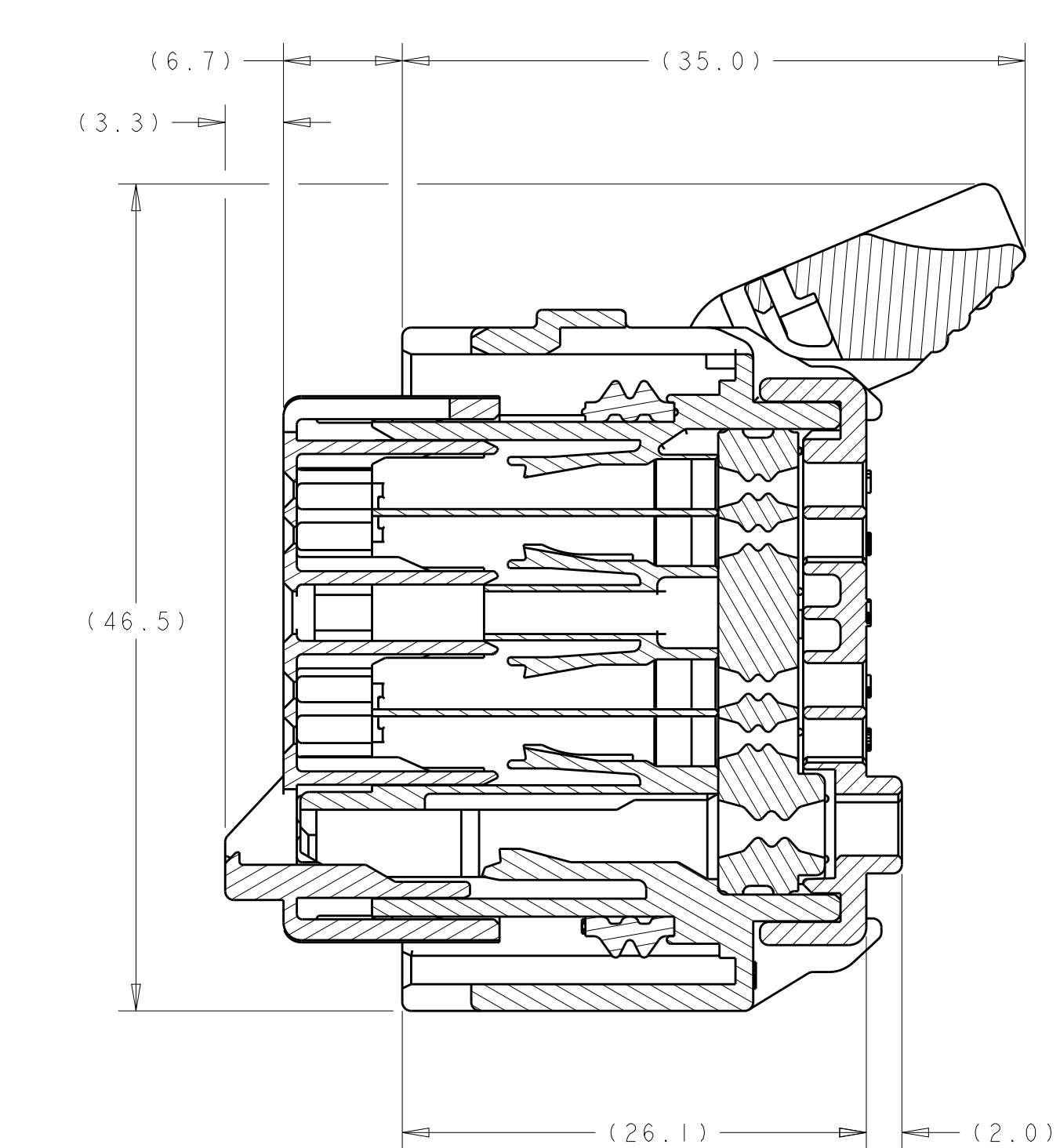
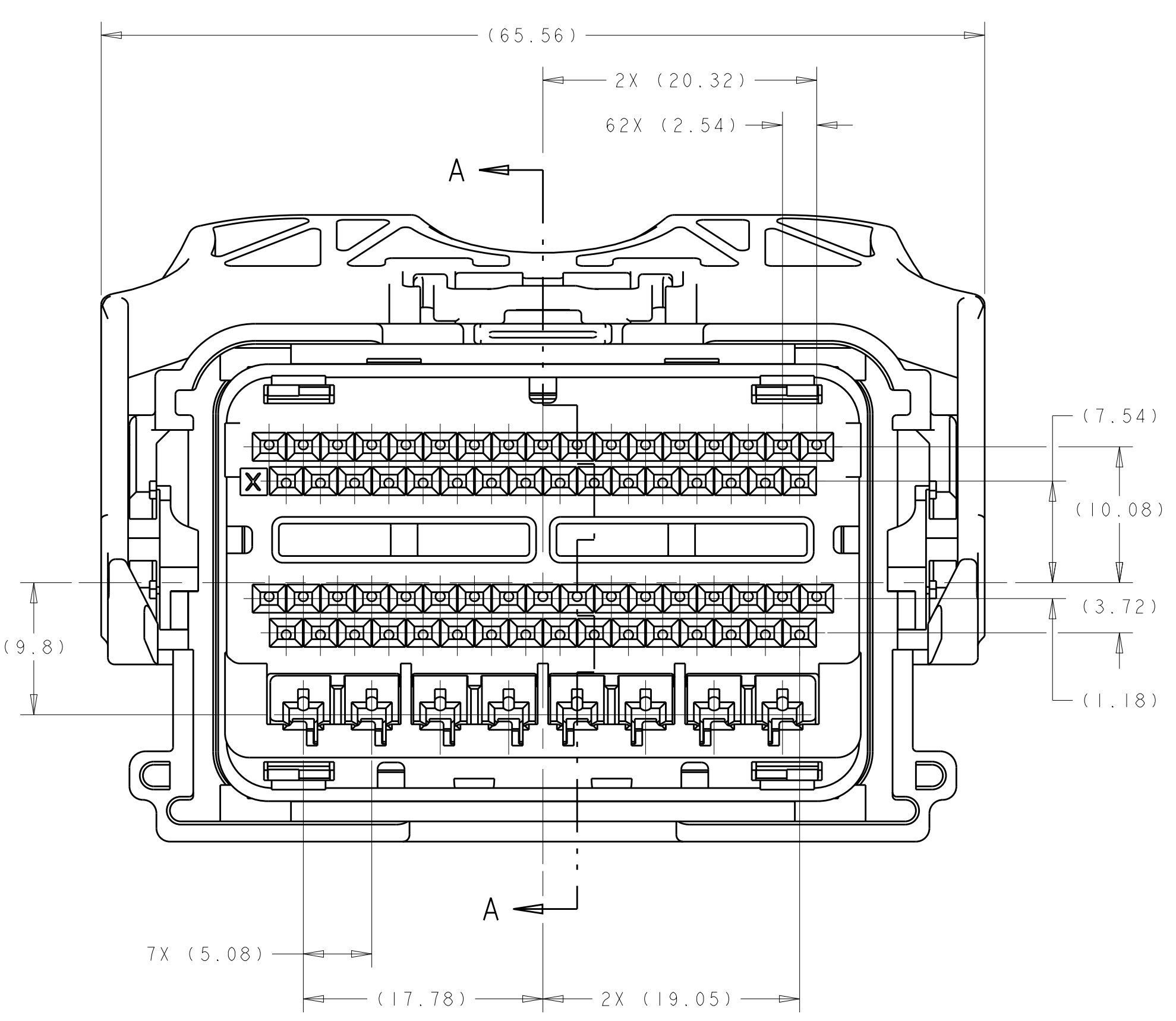

SECTION A-A SHOWING THE TPA AND LEVER IN THEIR PRE-LATCHED POSITIONS (DELIVERY CONDITION)

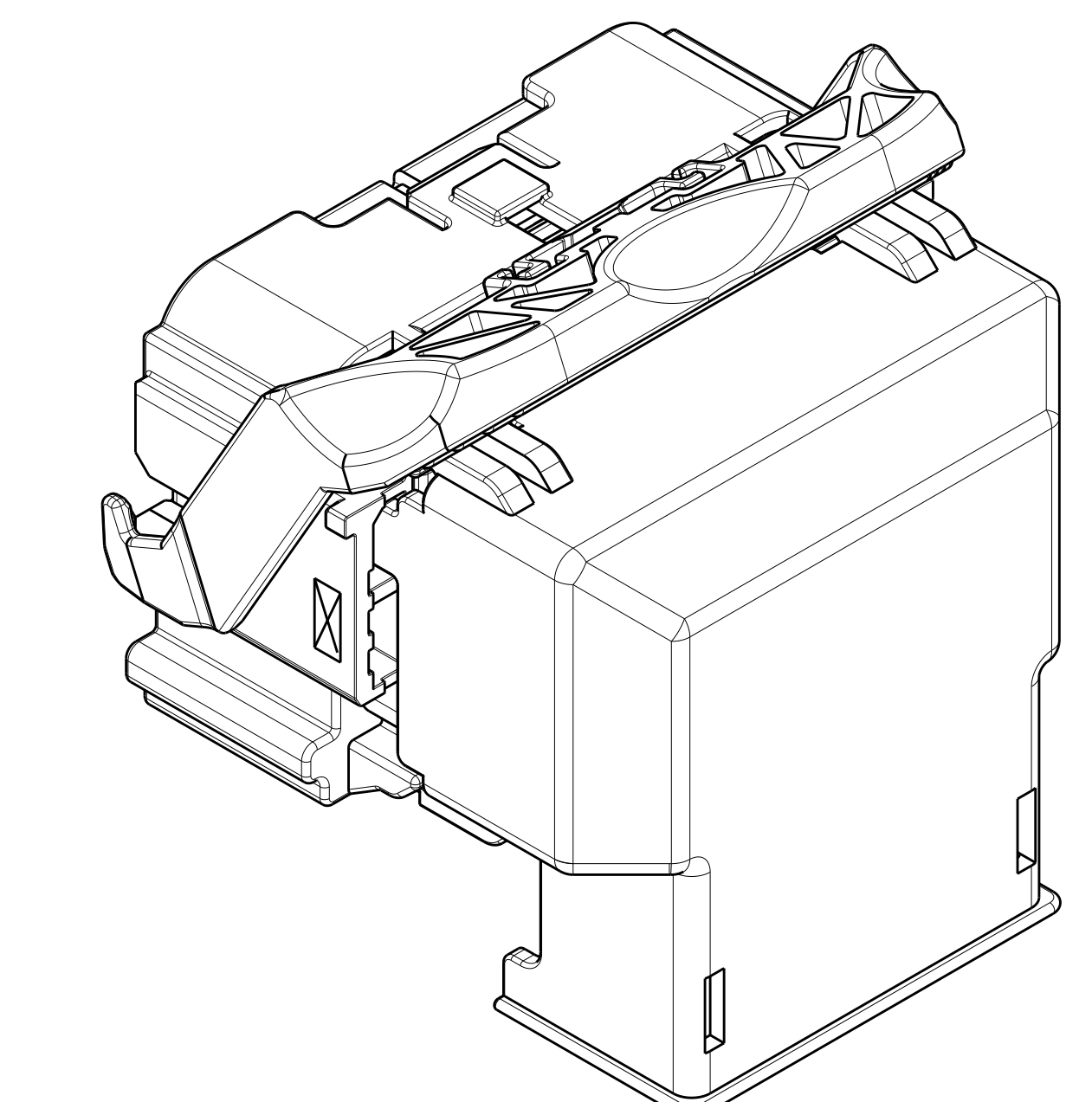
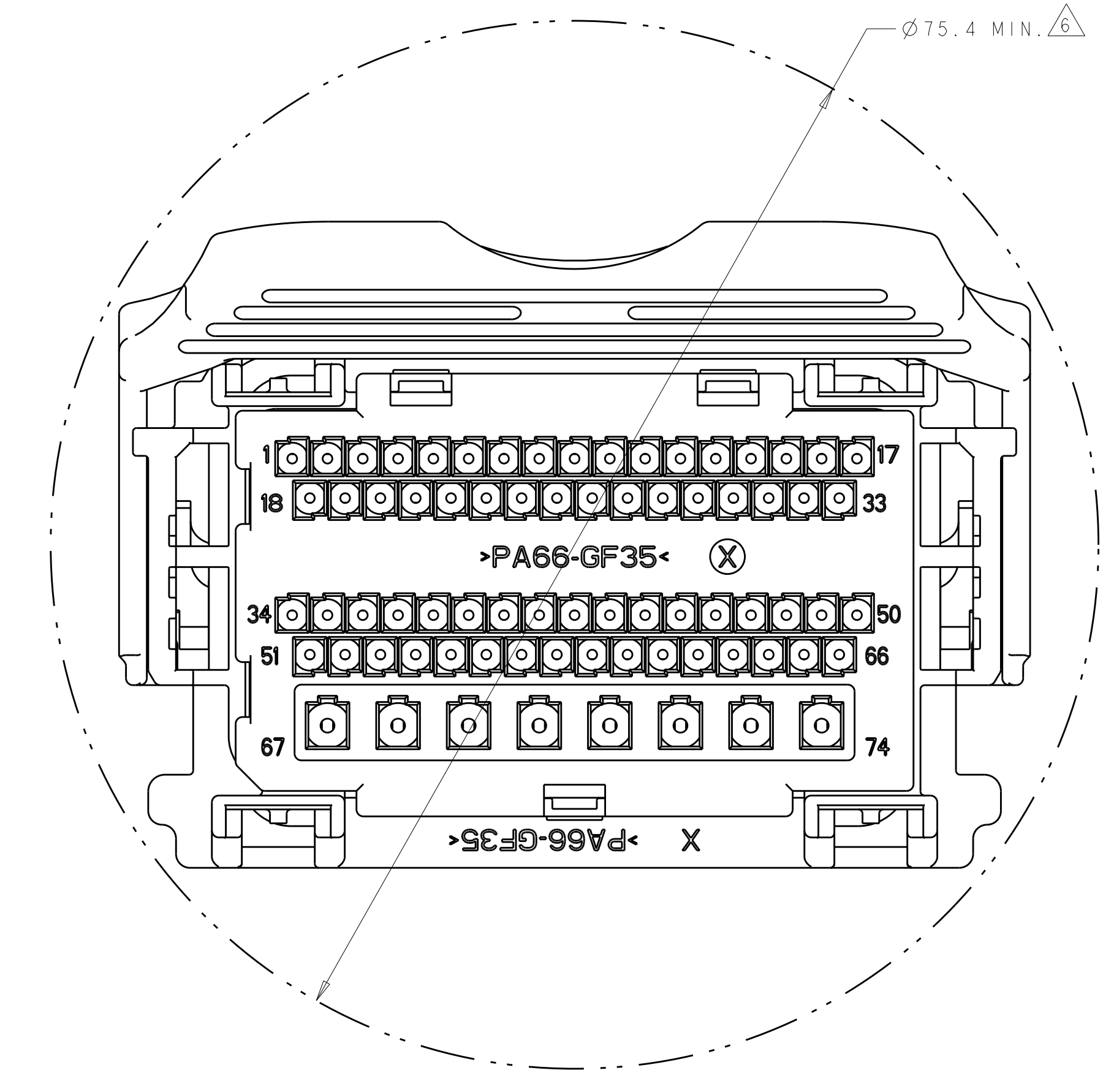

ISOMETRIC VIEW SHOWING THE OPTIONAL 90° EXIT WIRE GUIDE SCALE 2:1

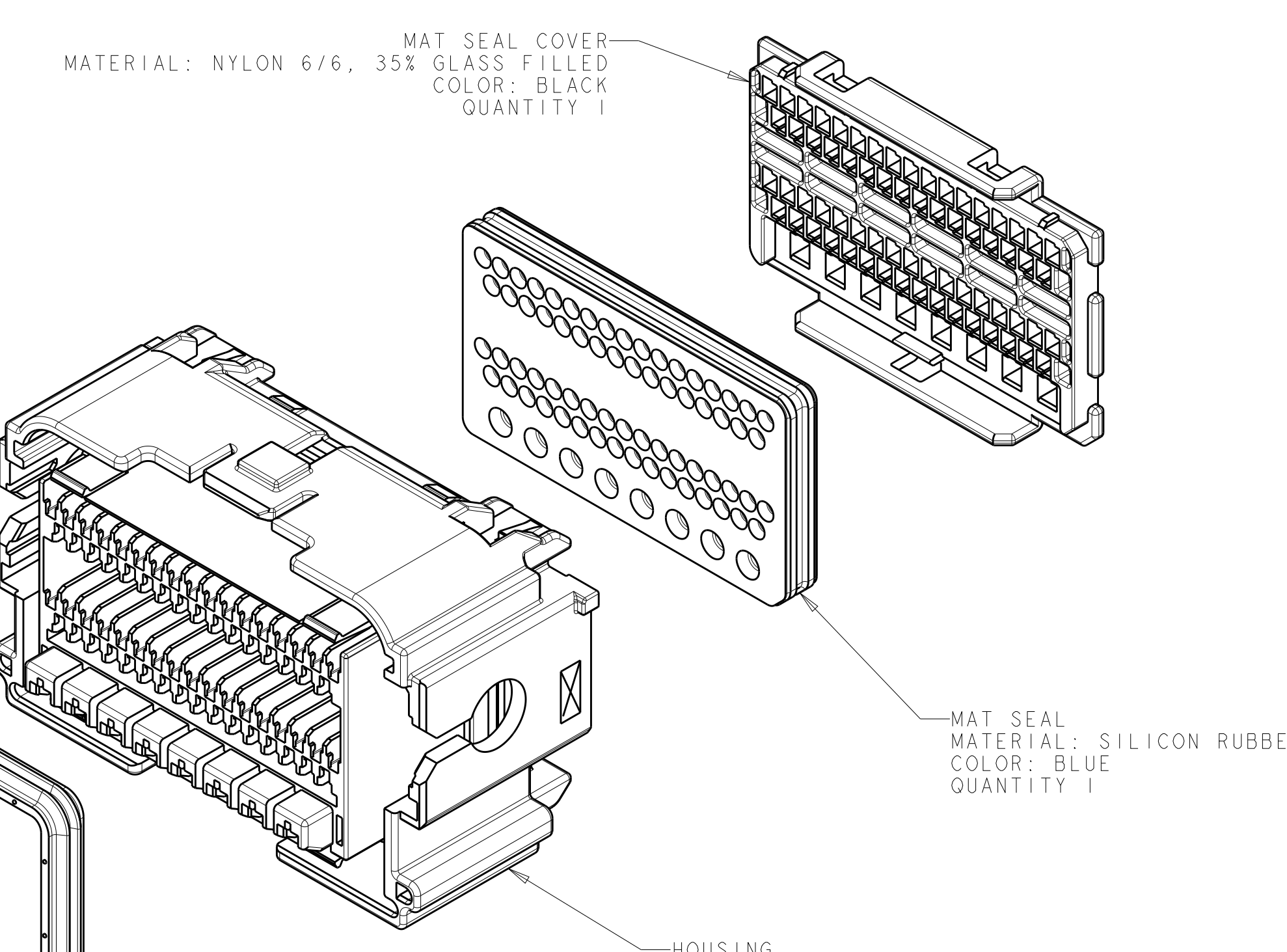
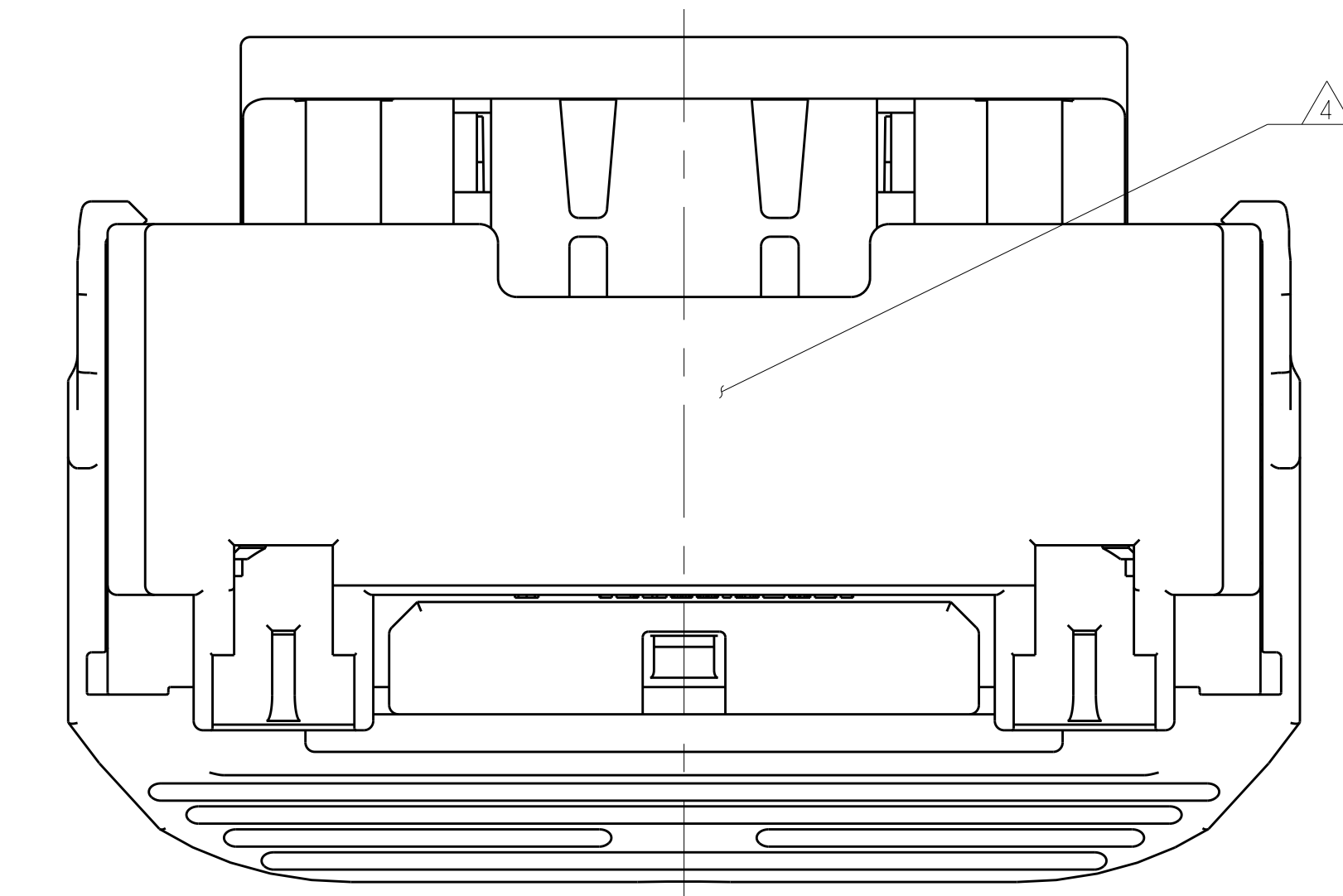

EXPLODED ISOMETRIC VIEW PART NUMBER: 776905-1 SHOWN FOR REFERENCE ONLY SCALE 2:1

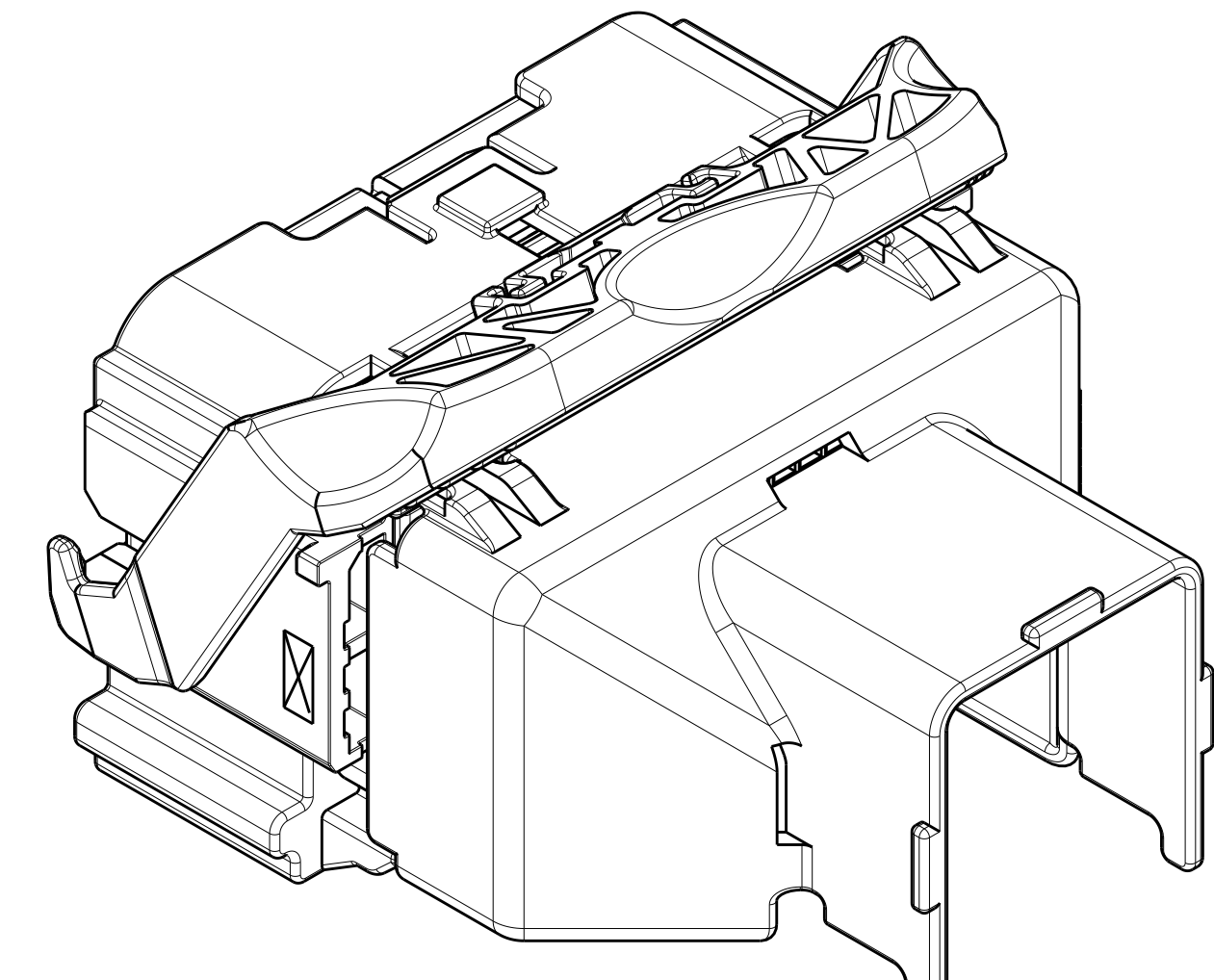

ISOMETRIC VIEW SHOWING THE OPTIONAL IN-LINE EXIT WIRE GUIDE SCALE 2:1

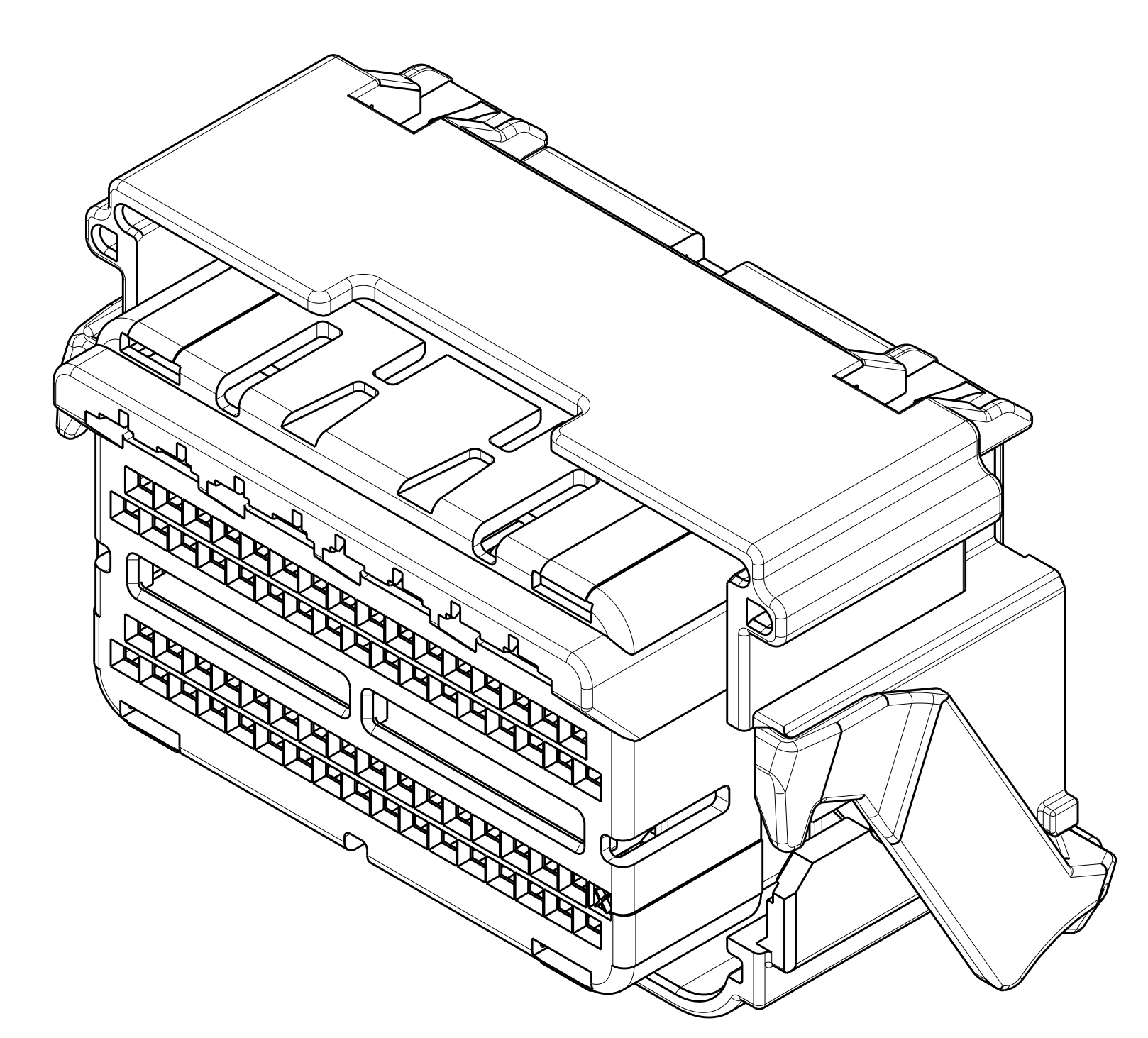

ISOMETRIC VIEWS

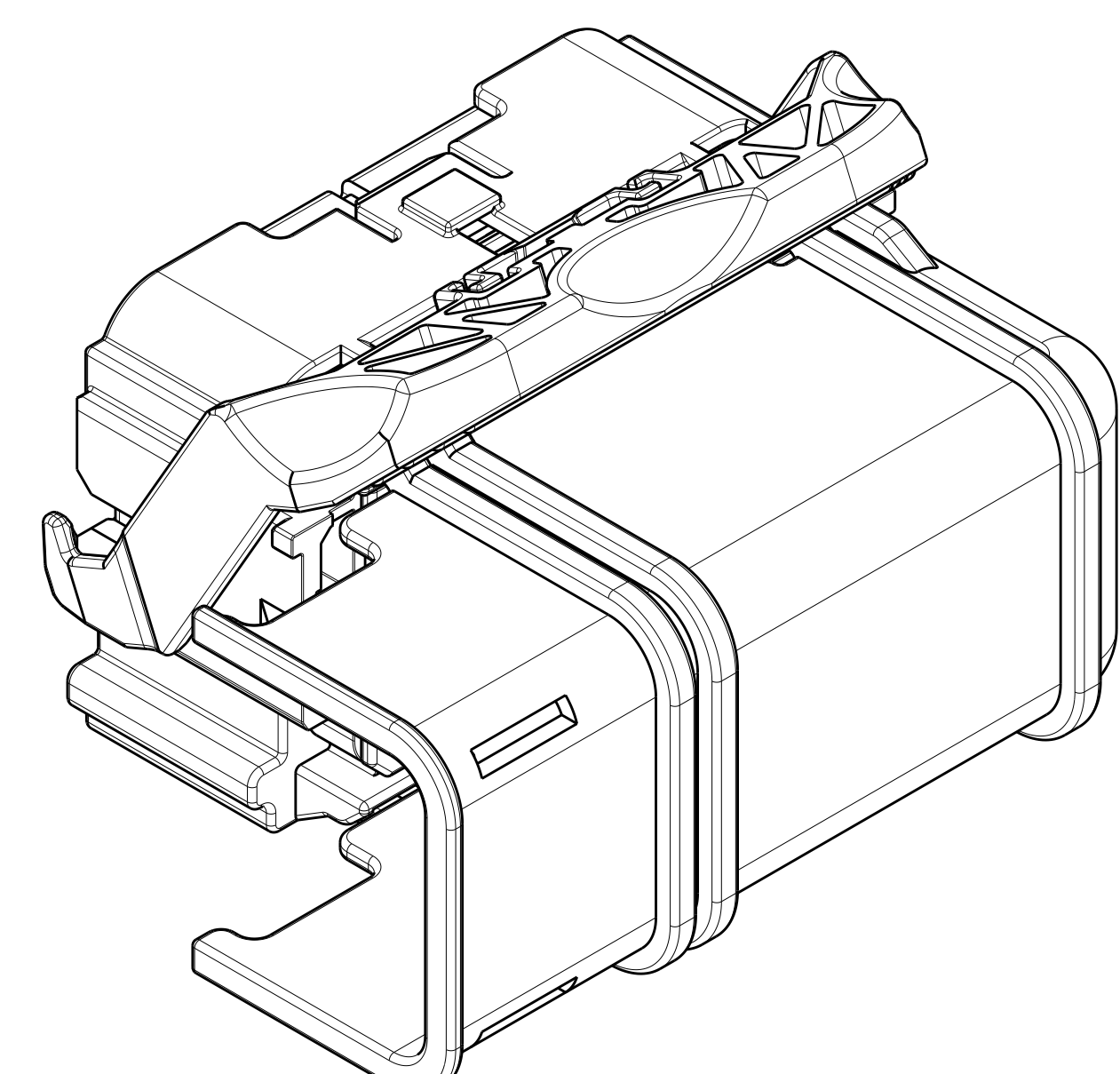

ISOMETRIC VIEW SHOWING THE OPTIONAL SIDE EXIT WIRE GUIDE SCALE 2:1

- PART NUMBER 776905-1 SHOWN ON THE DRAWING.
- THE TPA AND LEVER ARE SHIPPED IN THEIR PRE-LATCHED POSITIONS.
- ASSEMBLIES ARE SHIPPED IN TRAYS.
- TRACEABILITY CODE (YY = TWO DIGIT YEAR, JJJ = THREE DIGIT JULIAN DAY, HH = TWO DIGIT MILITARY HOUR) AND CUSTOMER PART NUMBER PRINTED IN THIS LOCATION AT ASSEMBLY.
- APPLICABLE WIRE ROUTING GUIDE(S): (SOLD SEPARATELY)
 1438133-1 = 90° DEGREE EXIT AWAY FROM THE LEVER
 1488374-1 = IN-LINE EXIT
 776880-1 = SIDE EXIT, CAN BE ROUTED LEFT OR RIGHT.
 SEE SHEET 3 FOR AVAILABLE OPTIONS.
- MINIMUM FEED THROUGH CONDITION WITH 1mm CLEARANCE ALL AROUND. THIS FEED THROUGH CONDITION APPLIES TO ALL ASSEMBLIES WITH OR WITHOUT ANY OF THE WIRE ROUTING GUIDE OPTIONS.
- FOR A LIST OF APPLICABLE CONTACT TERMINALS (SOLD SEPARATELY) SEE THE APPLICABLE TERMINAL TABLE.
- APPLICABLE HEADER INTERFACE DRAWING 1456714 IS AVAILABLE UPON REQUEST. A COPY OF THIS DRAWING CAN BE OBTAINED FROM THE TYCO ELECTRONICS PRODUCT MANAGER, VIA YOUR TYCO ELECTRONICS SALES REPRESENTATIVE OR CUSTOMER SERVICE.
- THIS ASSEMBLY HAS NOT PASSED VALIDATION TESTING.
- TYCO ELECTRONICS TAKE EXCEPTION TO THE USCAR-2 MATING AND UN-MATING FORCES REQUIREMENTS UNTIL TESTING CAN BE CONDUCTED TO DETERMINE THE ACTUAL VALUES OF THE MATING AND UN-MATING FORCES.
- REFERENCE TYCO ELECTRONICS INSTRUCTION SHEET 408-8893.

| APPLICABLE TERMINALS (FOR REFERENCE ONLY) | | | | | |
|---|------------------|-----------------------|---------|----------------------------|----------------|
| PART NUMBER | SUPPLIER | NOMINAL TERMINAL SIZE | PLATING | METRIC WIRE SIZES | SAE WIRE SIZES |
| 33012-0002 | MOLEX | 1.5 | TIN | 0.50 - 1.50mm ² | 16-20AWG |
| 1393367-2 | TYCO ELECTRONICS | 0.64 | SILVER | 0.22 - 0.35mm ² | 22AWG |
| 1393366-2 | TYCO ELECTRONICS | 0.64 | SILVER | 0.50 - 0.75mm ² | 18-20AWG |
| 1393365-1 | TYCO ELECTRONICS | 0.64 | GOLD | 0.50 - 0.75mm ² | 18-20AWG |
| 1393364-1 | TYCO ELECTRONICS | 0.64 | GOLD | 0.22 - 0.35mm ² | 22AWG |

THIS DRAWING IS A CONTROLLED DOCUMENT.

| | |
|-------------------|--------------|
| DATE: 31 AUG 2006 | BY: FORSLER |
| DATE: 31 AUG 2006 | CHK: VALASEK |
| DATE: 31 AUG 2006 | APP'D: RAY |

NAME: PLUG ASSEMBLY, 74 WAY, SEALED, HYBRID, FEMALE

SIZE: 3.1 SHEET 1 OF 3

SCALE: 2:1

REV: A5

| REVISIONS | | | |
|-----------|------|----|------|
| REV | DATE | BY | APPV |
| 1 | | | |
| 2 | | | |
| 3 | | | |
| 4 | | | |
| 5 | | | |
| 6 | | | |
| 7 | | | |
| 8 | | | |

WIRE ROUTING GUIDE OPTIONS

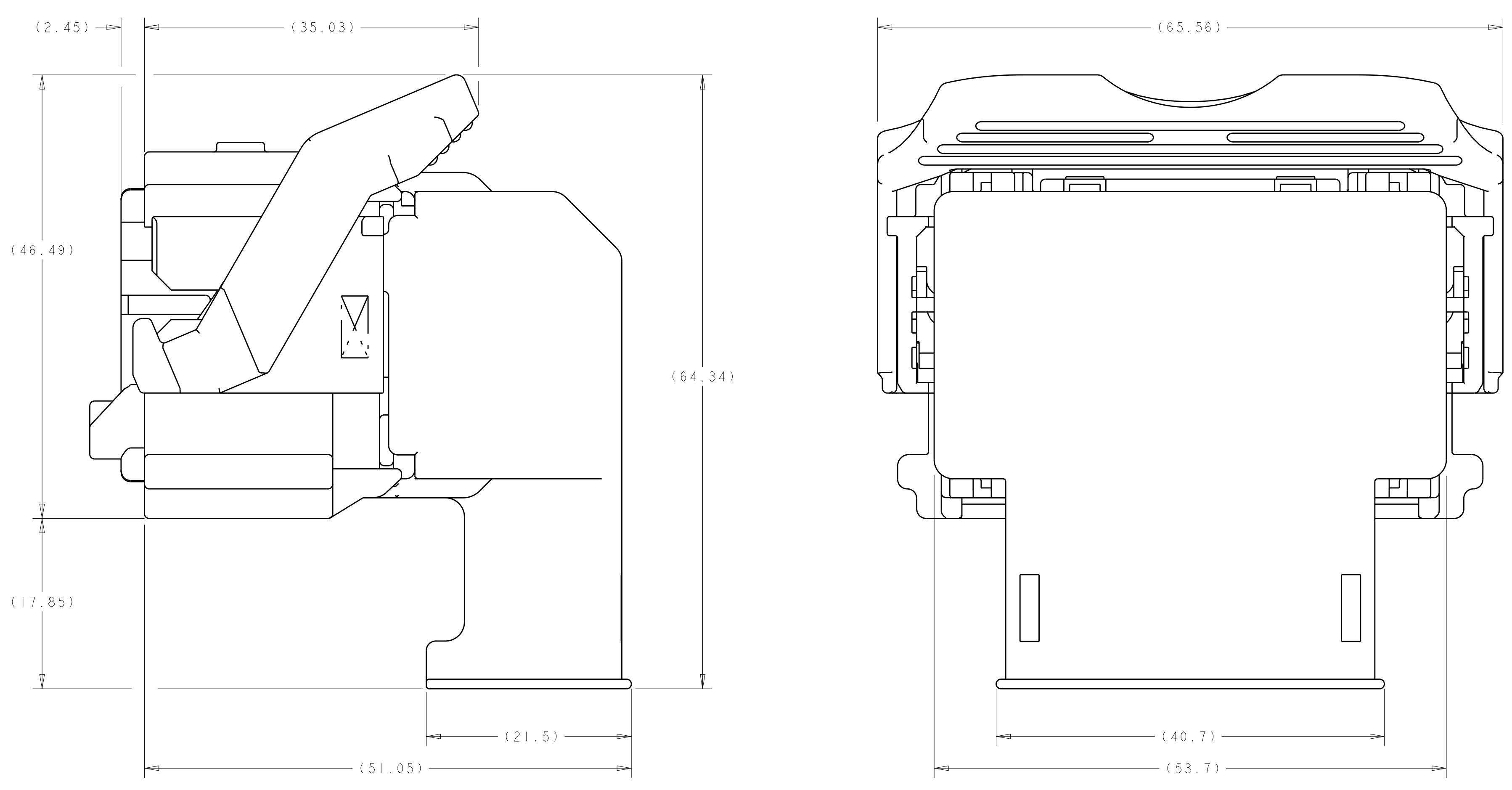

OPTION #1: 90° EXIT

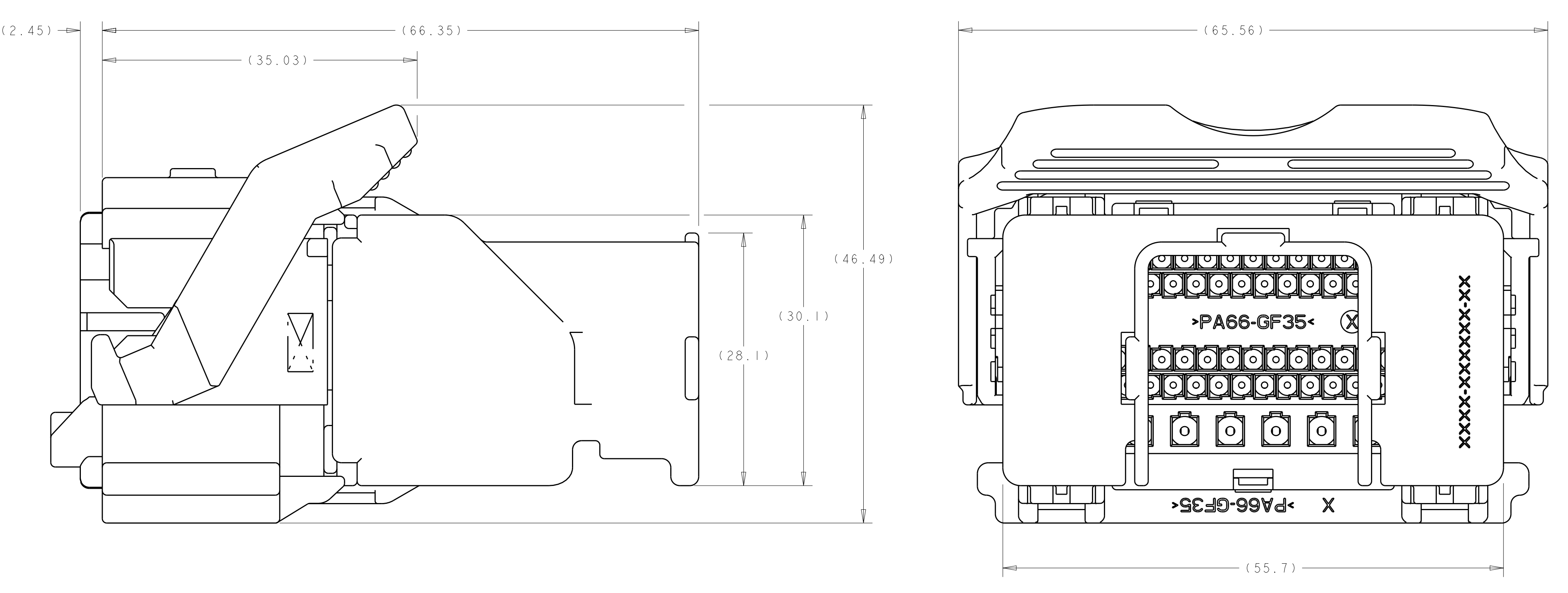

OPTION #2: IN-LINE EXIT

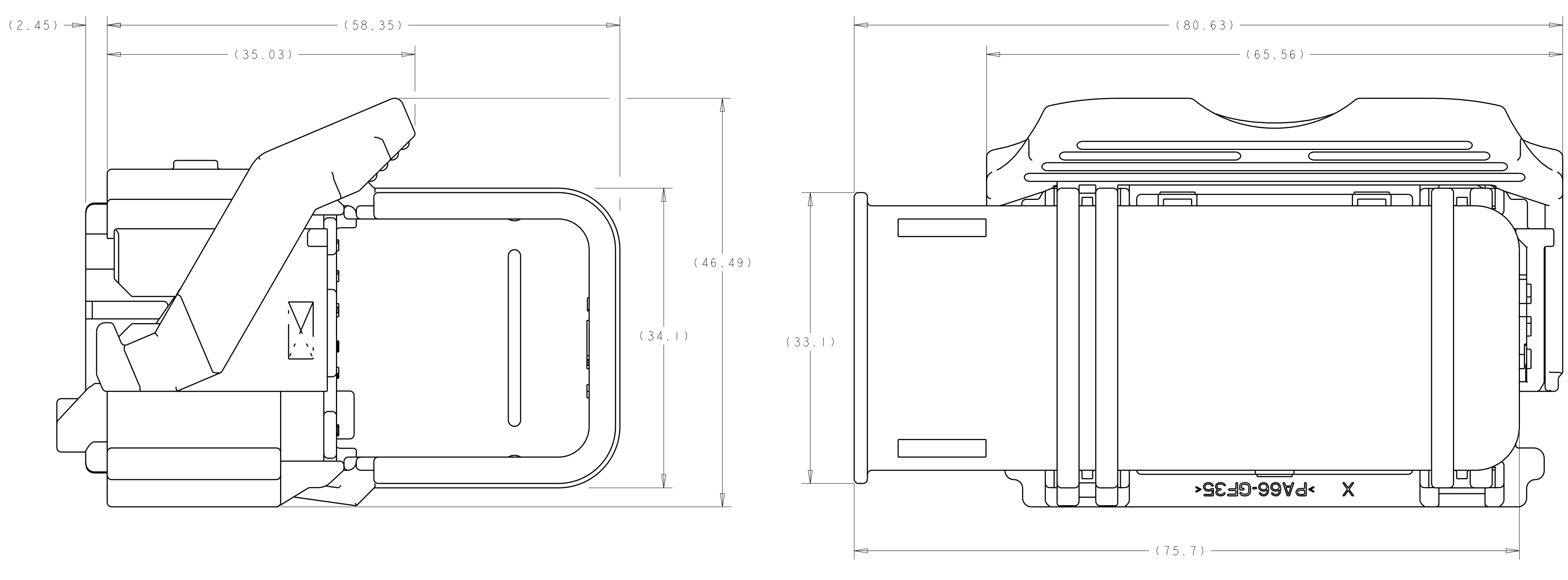

OPTION #3: SIDE EXIT
(EITHER RIGHT EXIT OR LEFT EXIT)

KEYING OPTIONS

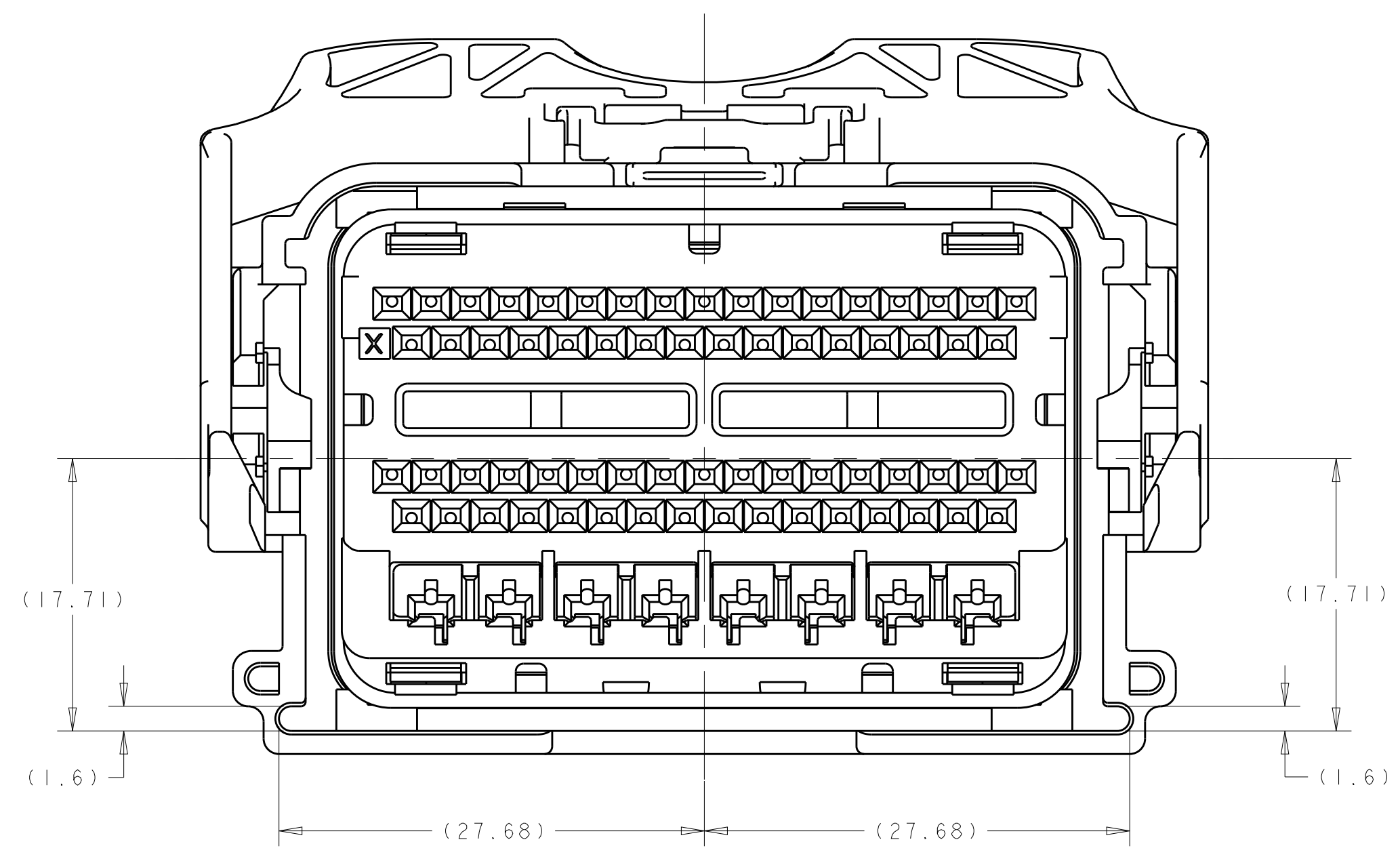

KEY A

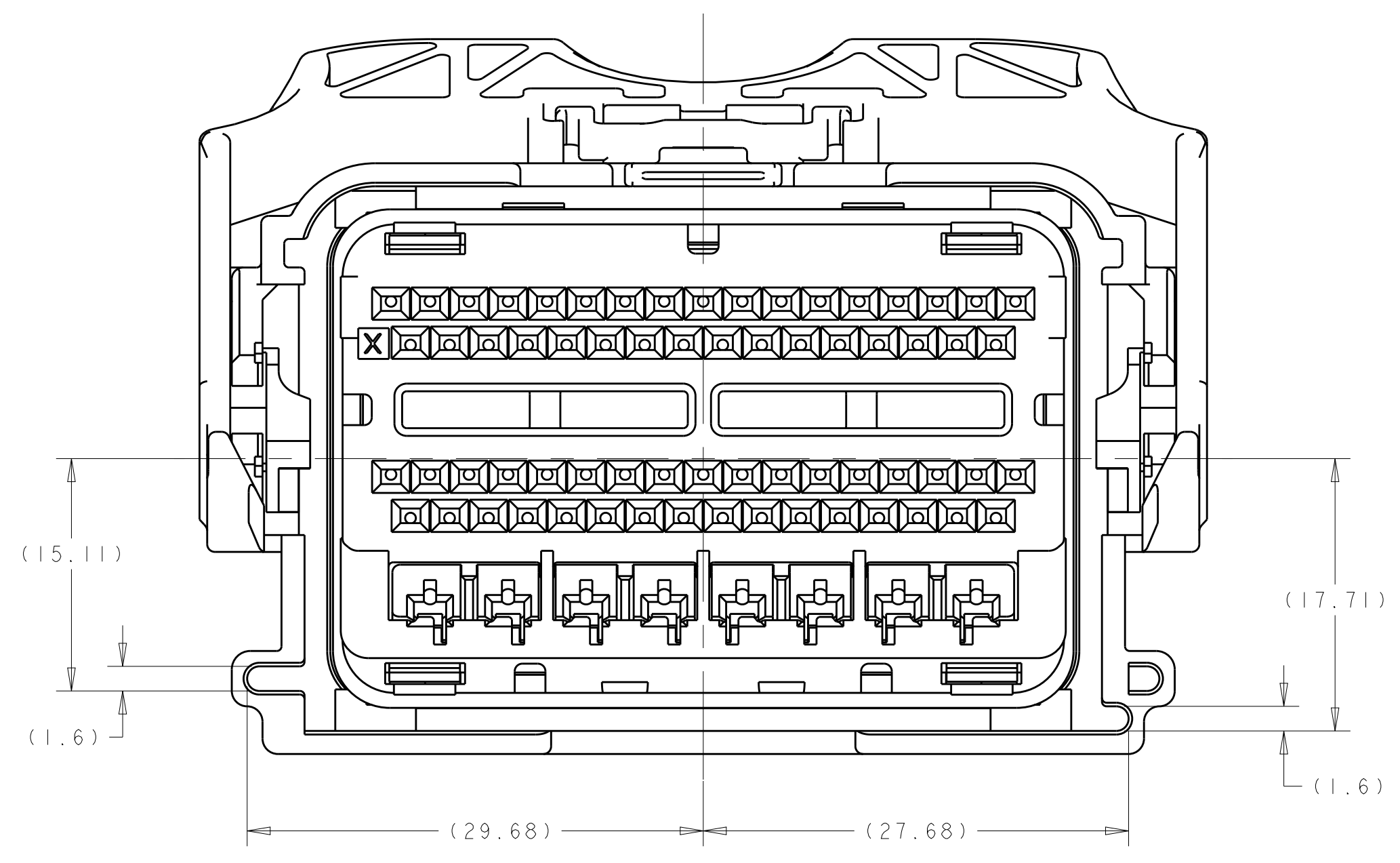

KEY B

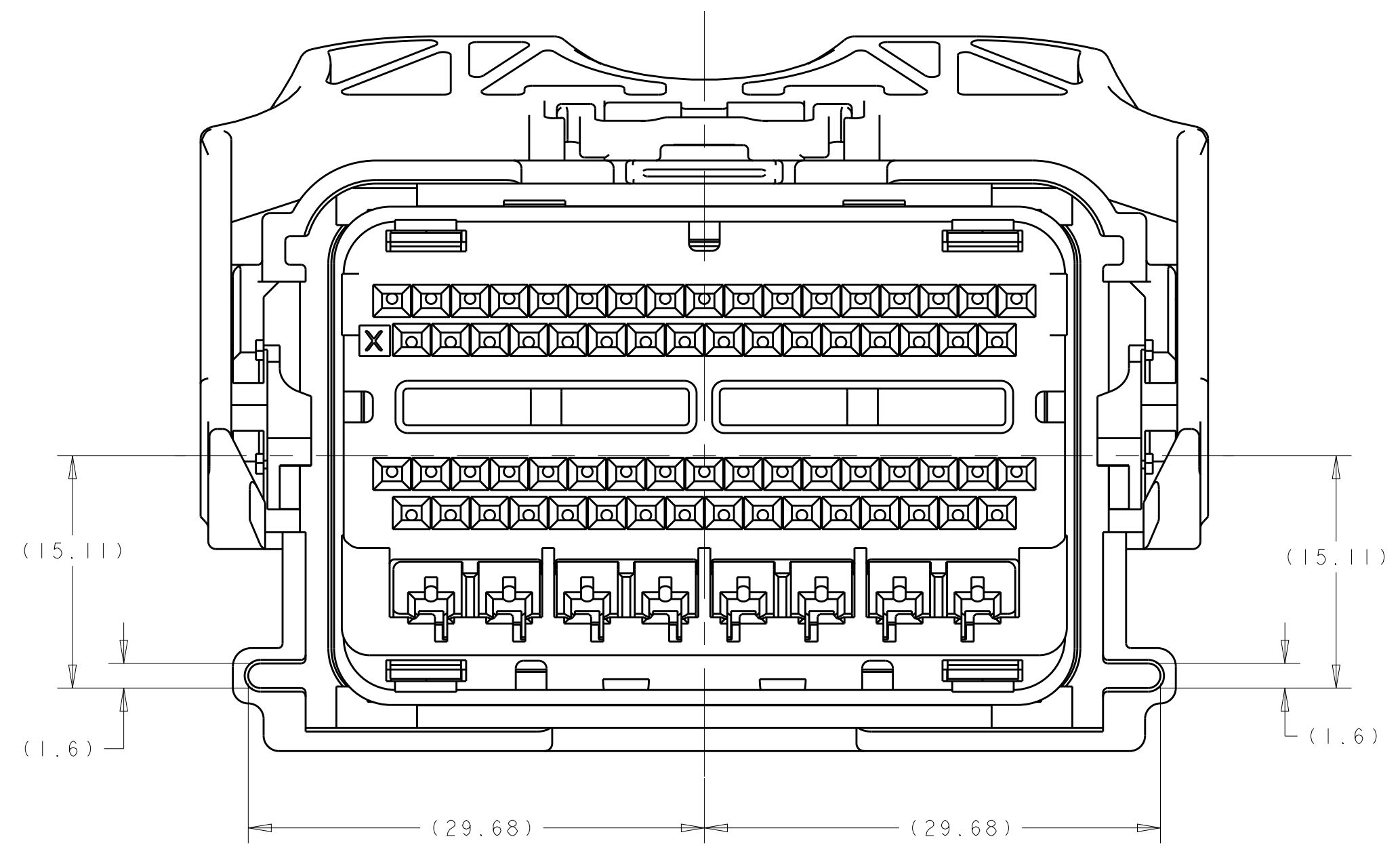

KEY C

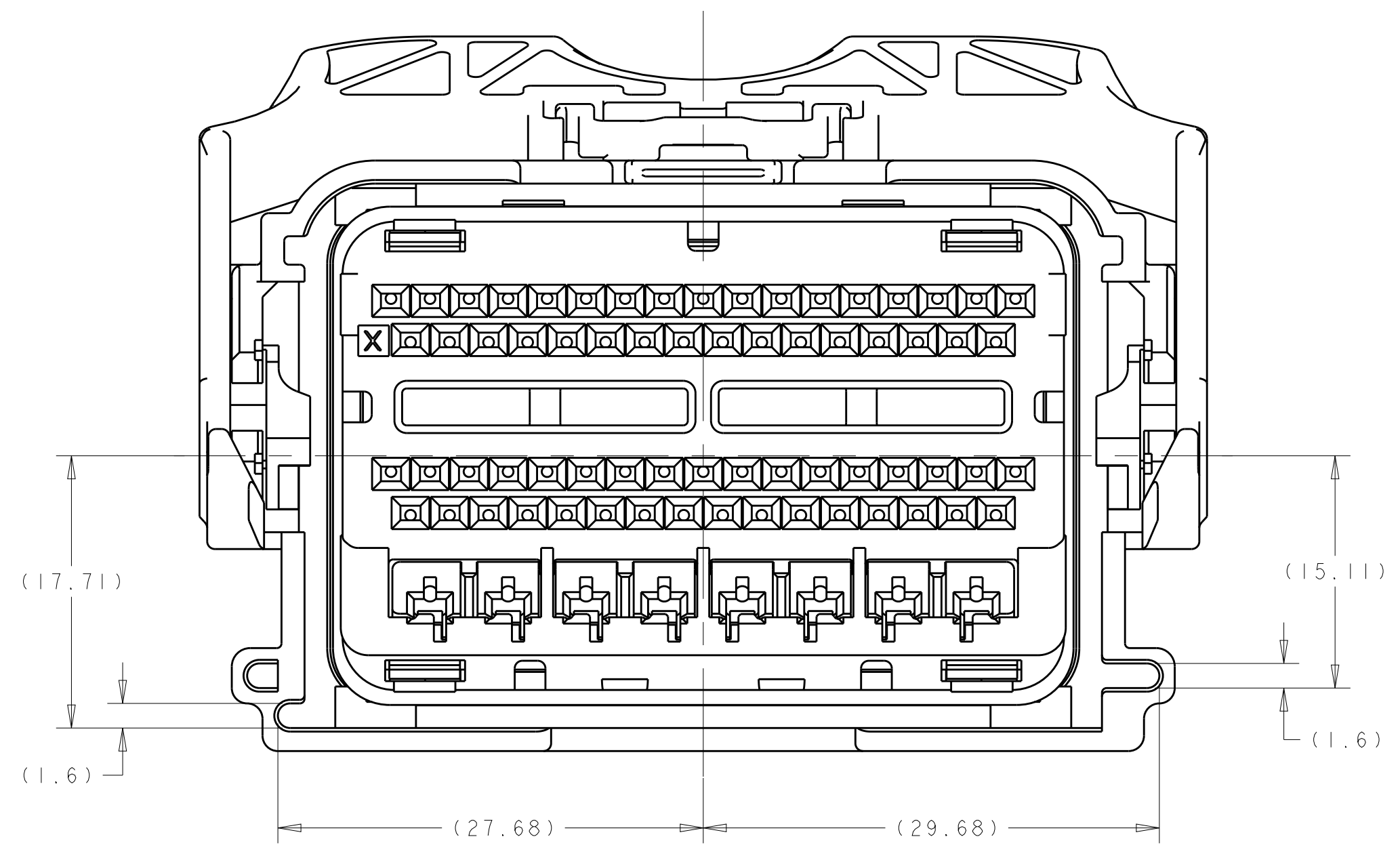

KEY D

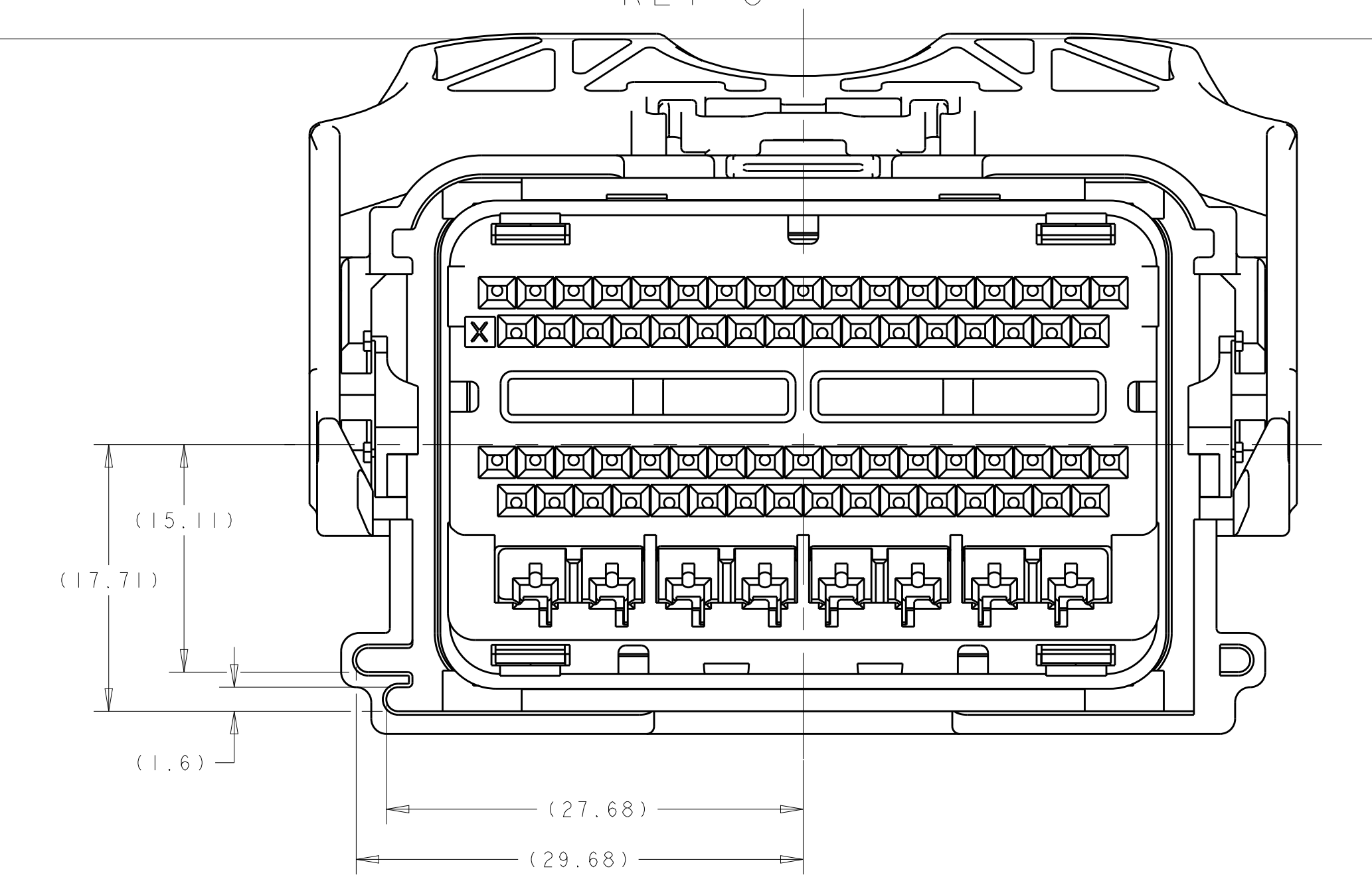

KEY E

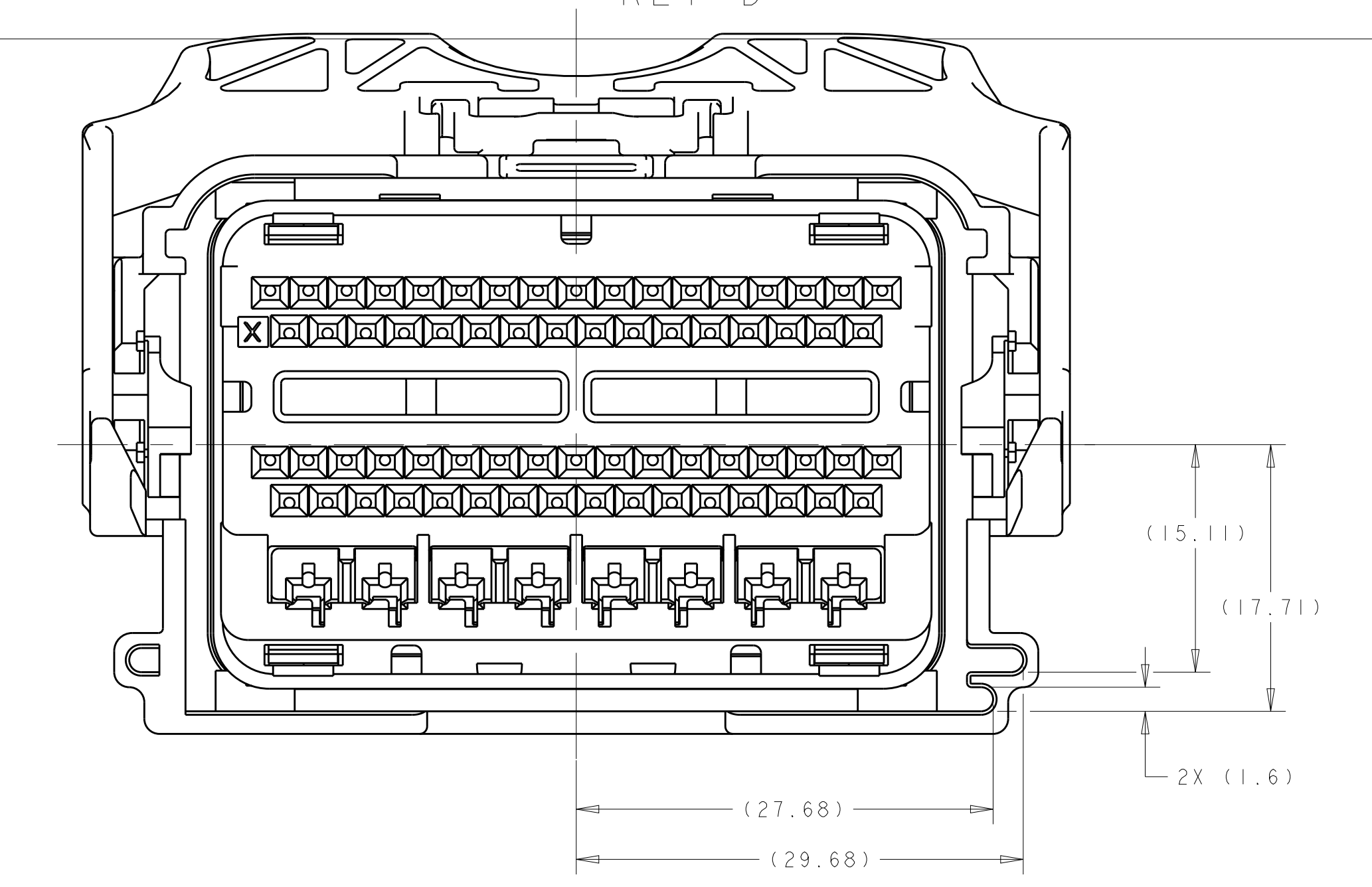

KEY F

THIS DRAWING IS A CONTROLLED DOCUMENT.

| | | | |
|-------------------|---------------|-----------------|--------------|
| DATE: 31 AUG 2006 | BY: M. FORLIS | CHK: J. VALASKI | APPV: W. RAY |
| REV: 3 | REV: 3 | REV: 10 | REV: 3 |

TE Connectivity

PLUG ASSEMBLY, 74 WAY, SEALED, HYBRID, FEMALE

SCALE: 3:1 SHEET 3 OF 3

单击下面可查看定价，库存，交付和生命周期等信息

[>>TE Connectivity\(泰科\)](#)