

THIS DRAWING IS UNPUBLISHED. RELEASED FOR PUBLICATION
 © COPYRIGHT BY TYCO ELECTRONICS CORPORATION. ALL INTERNATIONAL RIGHTS RESERVED.

LOC	DIST	REVISIONS			
P	LTR	DESCRIPTION	DATE	DWN	APVD
AF	50				
		C1 REVISED PER ECR-09-002564	12FEB09	HMR	KR
		D ECR-13-008483	06AUG13	XJ	DZ

IDENTIFICATION NUMBER FOR MAGNET WIRE RANGE

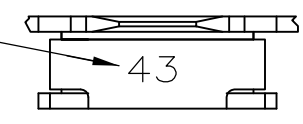

- 1 MAG-MATE CAVITY SPECIFICATION
- 2 CONTINUOUS STRIP ON REELS WITH TERMINALS LOCATED ON .330 CENTERS.
- 3 AFTER INSERTION INTO PLASTIC HOLDER, TAB PORTION MUST BE BENT OVER 45° TO 90° OR POTTED-IN TO PREVENT PULL-OUT WHEN MATING RECEPTACLE IS DISCONNECTED.
- 4 TWO #14-13.5 COPPER MAGNET WIRES ACCEPTABLE AT CAVITY ANVIL HEIGHT OF .155-.165.

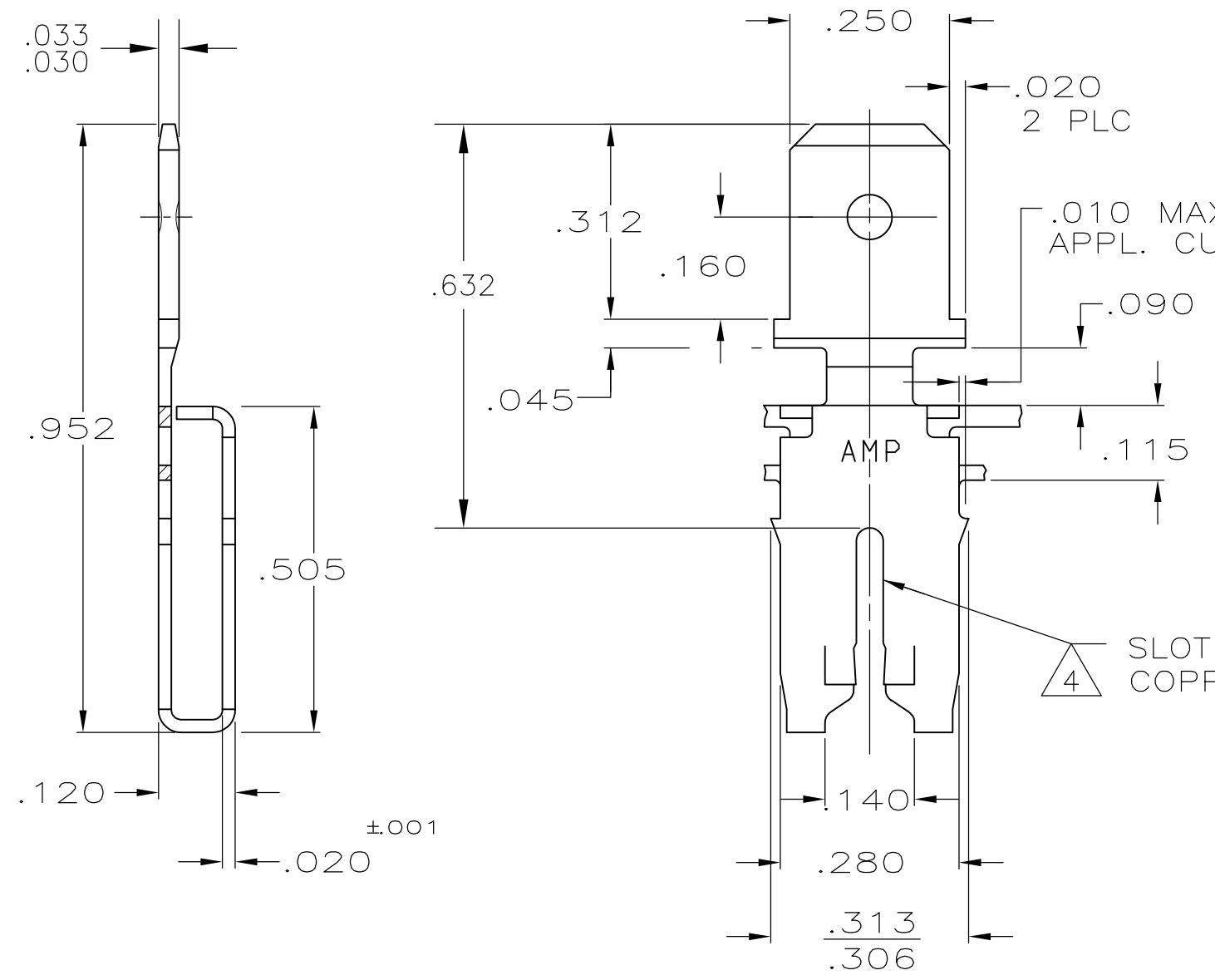

63465-1
PART NO

THIS DRAWING IS A CONTROLLED DOCUMENT.		DWN M.S. FEHER 4/21/87	Tyco Electronics Corporation Harrisburg, PA 17105-3608			
DIMENSIONS: INCHES	TOLERANCES UNLESS OTHERWISE SPECIFIED:	CHK G YETTER 4/21/87	NAME TAB, .250 FASTON,™ MAG-MATE™			
		APVD J SWARTZ 4/21/87				
MATERIAL #4H PRE-MILLED BRASS	FINISH TIN PLATE	PRODUCT SPEC	SIZE	CAGE CODE	DRAWING NO	RESTRICTED TO
		APPLICATION SPEC	114-2066	A300779	C-63465	—
CUSTOMER DRAWING			SCALE 4:1	SHEET 1 OF 1	REV D	

单击下面可查看定价，库存，交付和生命周期等信息

[>>TE Connectivity\(泰科\)](#)