

REVISIONS				
P.	LTH	DESCRIPTION	DATE	APVD
A		RELEASED PER ECO 17-012487	8-28-17	CT DH

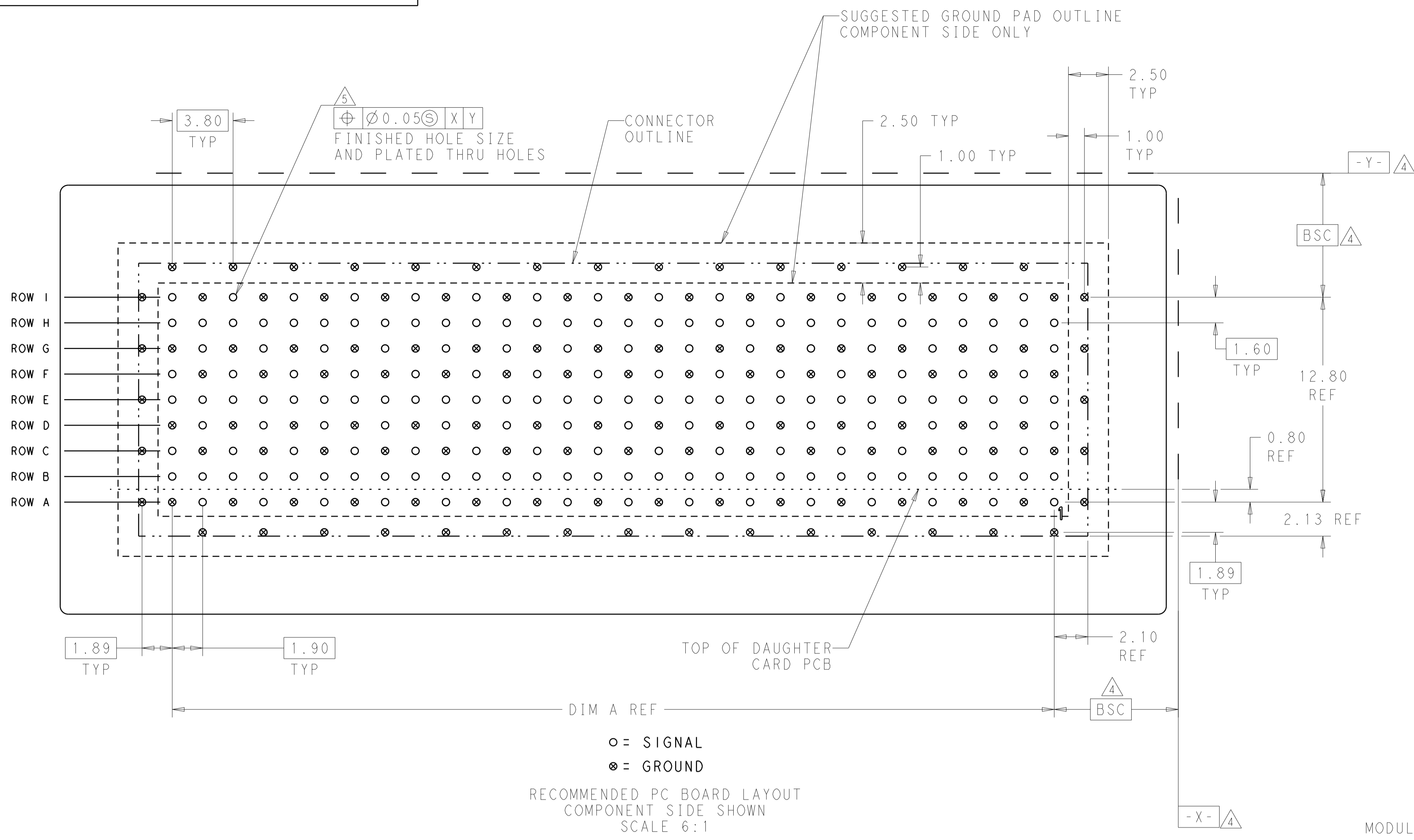

○ = SIGNAL
 ⊗ = GROUND
 RECOMMENDED PC BOARD LAYOUT
 COMPONENT SIDE SHOWN
 SCALE 6:1

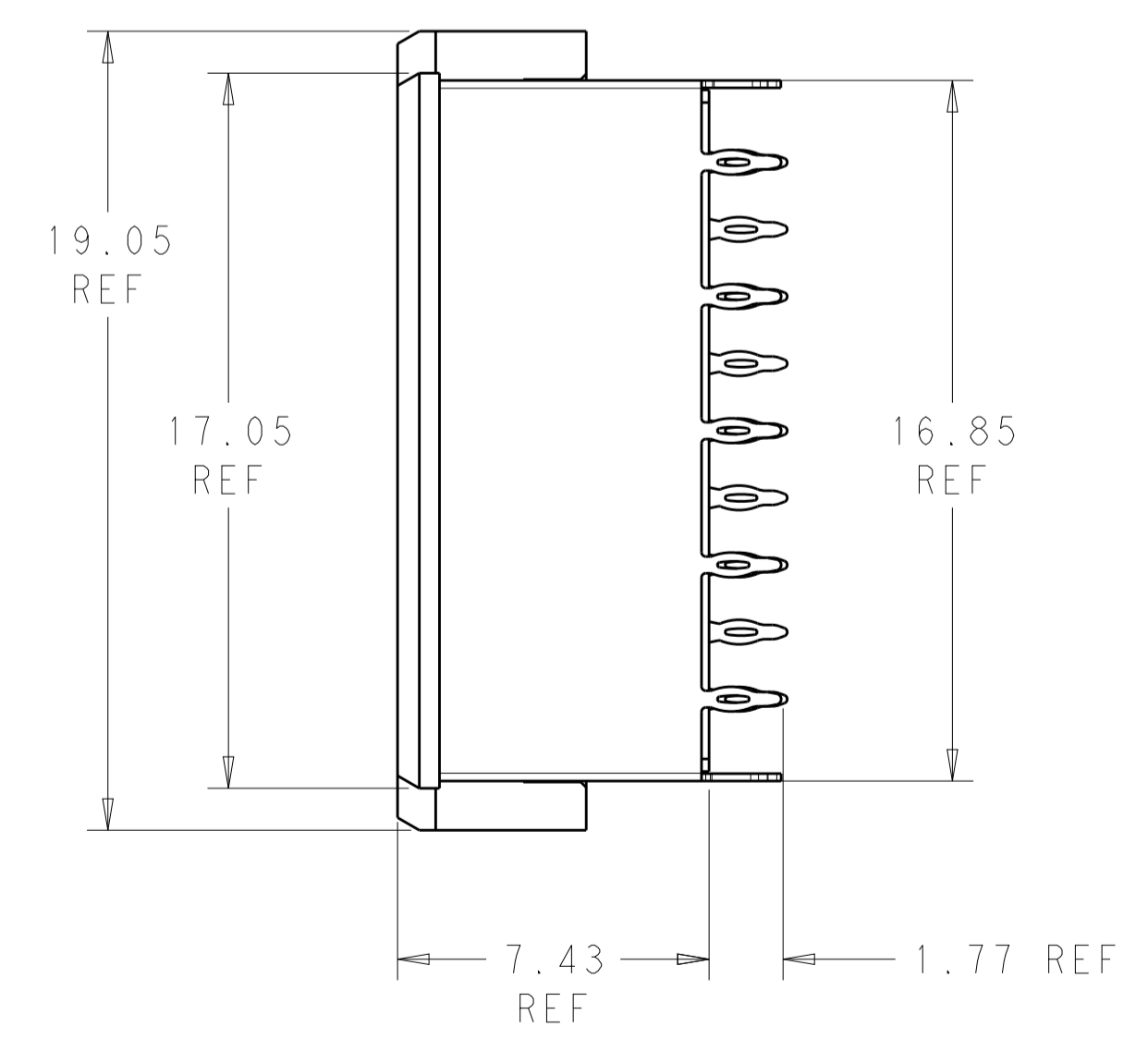
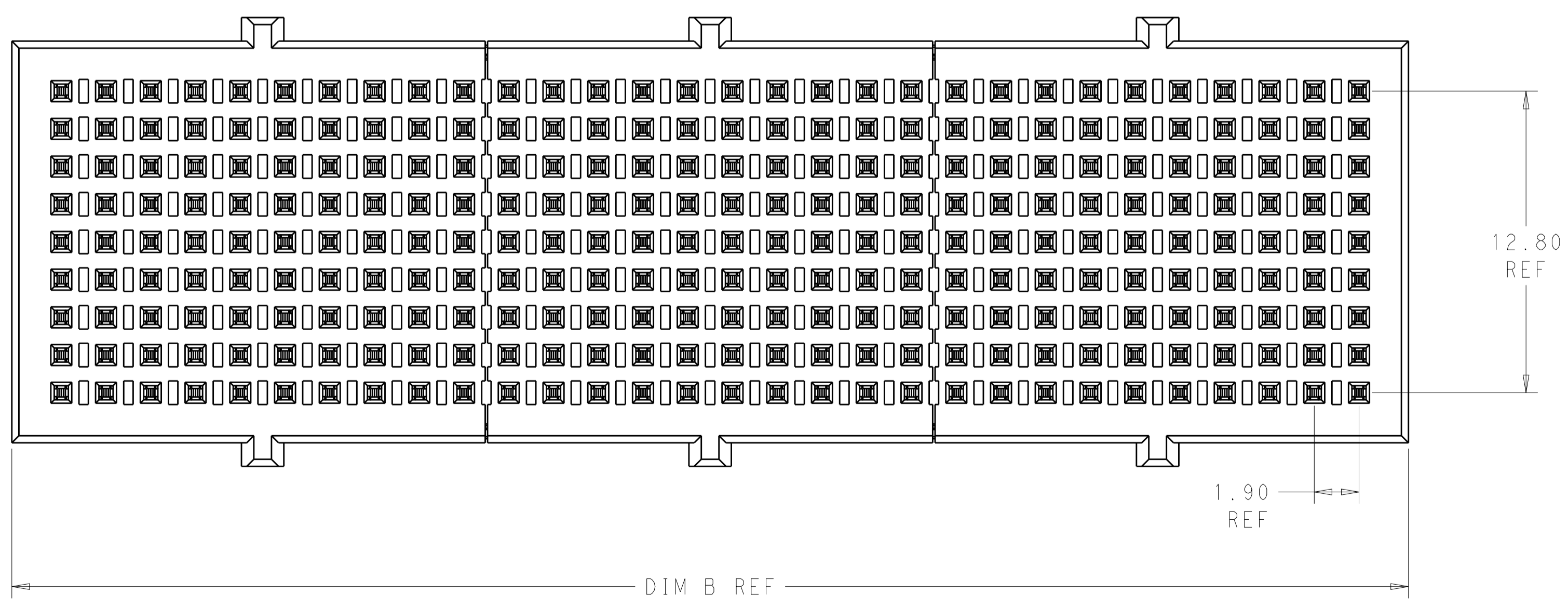
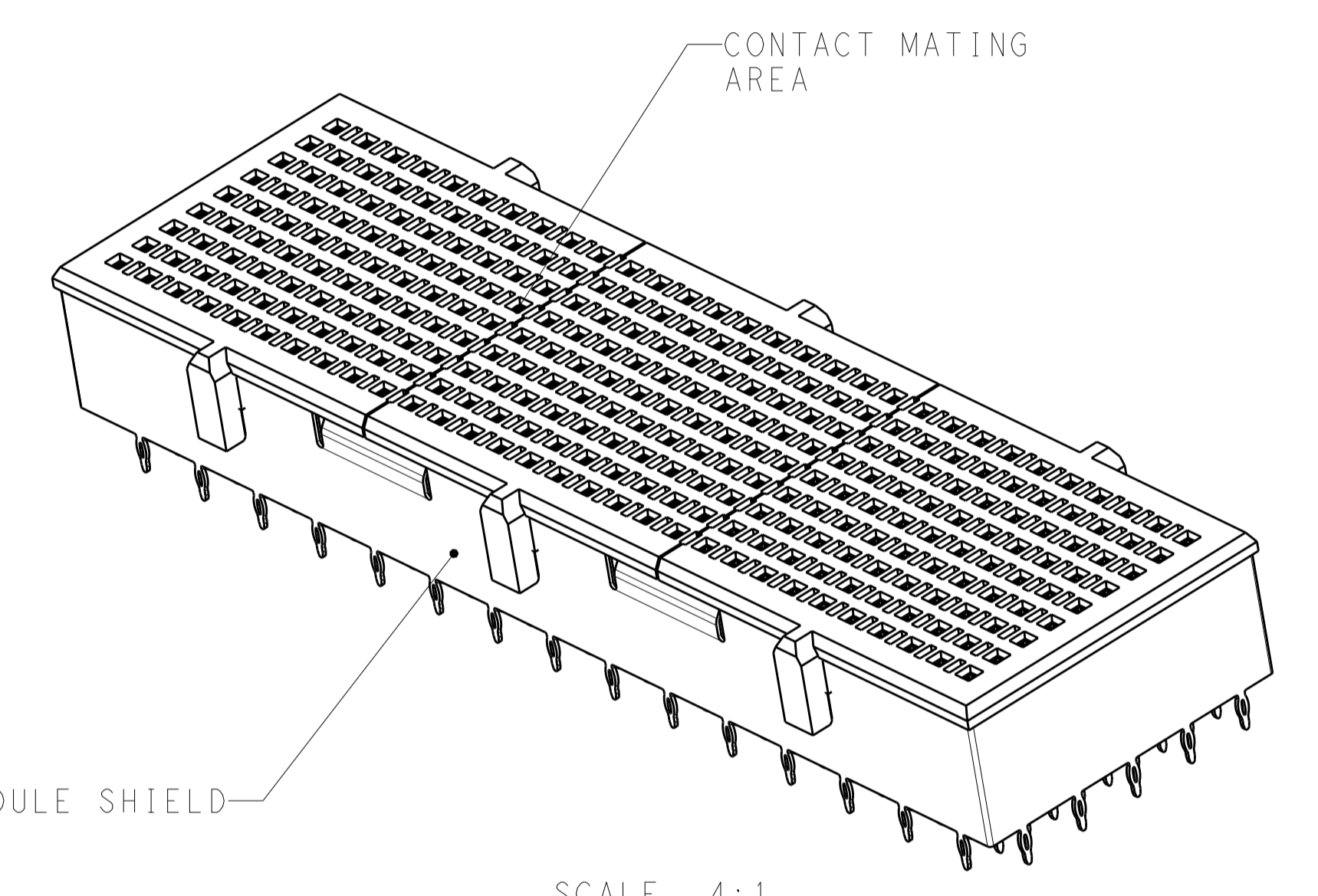

THIS DRAWING IS A CONTROLLED DOCUMENT.		OWN: D. BELACK 23JUL2010	 TE Connectivity
DIMENSIONS:		CHK: A. TSANG 23JUL2010	
TOLERANCES UNLESS OTHERWISE SPECIFIED:		APVD: M. McALONIS 23JUL2010	
mm		PRODUCT SPEC	
 0 PLC ±0.13 2 PLC ±0.05 3 PLC ±0.05 4 PLC ±0.05 ANGLES ±2°		NAME: Fortis Zd. 3-PAIR, VERTICAL SHIELDED MODULE ASSEMBLY	
MATERIAL		APPLICATION SPEC: 108-2409	SIZE: CAGE CODE DRAWING NO
FINISH		114-13267	RESTRICTED TO
		WEIGHT: -	A100779C=2102248
CUSTOMER DRAWING		SCALE: 6:1	SHEET 1 OF 2 REV A

REVISIONS				
P.	LTN	DESCRIPTION	DATE	APVD
-	-	SEE SHEET 1	-	-

- 1 MATERIAL:
 CONTACT - BERYLLIUM COPPER ALLOY
 HOUSING - BLACK LCP
 SHIELD - NICKEL SILVER PER UNS C77000
- 2 FINISH:
 MATING AREA: 1.27µm MIN GOLD OVER
 3.81µm MIN NICKEL
 COMPLIANT PIN AREA: 0.5µm MIN 93/7 SnPb OVER
 1.27µm MIN NICKEL
- 3 FINISH:
 MATING AREA: 1.27µm MIN GOLD OVER
 3.81µm MIN NICKEL
 COMPLIANT PIN AREA: 0.5µm MIN Sn OVER
 1.27µm MIN NICKEL
- 4 DATUMS AND BASIC DIMENSIONS ESTABLISHED BY CUSTOMER.
- 5 REFERENCE APPLICATION SPEC 114-13267 FOR RECOMMENDED PLATING THRU HOLE DIAMETER AND PLATING THICKNESS.

23.33	116.30	112.10	3	60 COLUMN	180	2-2102248-6
19.58	97.30	93.10	3	50 COLUMN	150	2-2102248-5
15.82	78.30	74.10	3	40 COLUMN	120	2-2102248-4
12.07	59.30	55.10	3	30 COLUMN	90	2-2102248-3
8.32	40.30	36.10	3	20 COLUMN	60	2-2102248-2
4.56	21.30	17.10	3	10 COLUMN	30	2-2102248-1
23.33	116.30	112.10	2	60 COLUMN	180	2102248-6
19.58	97.30	93.10	2	50 COLUMN	150	2102248-5
15.82	78.30	74.10	2	40 COLUMN	120	2102248-4
12.07	59.30	55.10	2	30 COLUMN	90	2102248-3
8.32	40.30	36.10	2	20 COLUMN	60	2102248-2
4.56	21.30	17.10	2	10 COLUMN	30	2102248-1
WEIGHT(g)	DIM "B"	DIM "A"	COMPLIANT PIN PLATING	DESCRIPTION	DIFF PAIRS	PART NUMBER

THIS DRAWING IS A CONTROLLED DOCUMENT.		OWN D. BELACK	23JUL2010	
DIMENSIONS: mm		CHK A. TSANG	APVD M. McALONIS	
TOLERANCES UNLESS OTHERWISE SPECIFIED:		PRODUCT SPEC		NAME Fortis Zd, 3-PAIR, VERTICAL SHIELDED MODULE ASSEMBLY
0 PLC ±0.13		108-2409		
2 PLC ±0.05		APPLICATION SPEC		SIZE CAGE CODE DRAWING NO A100779C=2102248
3 PLC ±		114-13267		
4 PLC ±		RESTRICTED TO		SCALE 6:1 SHEET 2 OF 2 REV A
ANGLES ±2°		CUSTOMER DRAWING		
FINISH		WEIGHT		

单击下面可查看定价，库存，交付和生命周期等信息

[>>TE Connectivity\(泰科\)](#)