

REVISIONS					
P	LTR	DESCRIPTION	DATE	DWN	APVD
E2		REVISED PER ECR-21-120754	16NOV2021	BDA	KR

- SPECIFICATIONS:  
MAGNET WIRE #18- #34 AWG  
1.02 mm(.040)- 0.16 mm(.006) DIA COPPER.
- POCKET RECOMMENDATION: #1601431
- TERMINAL APPLICATION TO COMPLY WITH TYCO ELECTRONICS SPECIFICATION 114-13166 FIGURE 10.
- PRELIMINARY - NOT FOR PREPRODUCTION
- OBSOLETE PARTS: OBSOLETE CIS STREAMLINING PER D.RENAUD/D.SINISI.
- TWO(2) TERMINALS SHOWN FOR ILLUSTRATION PURPOSES ONLY.

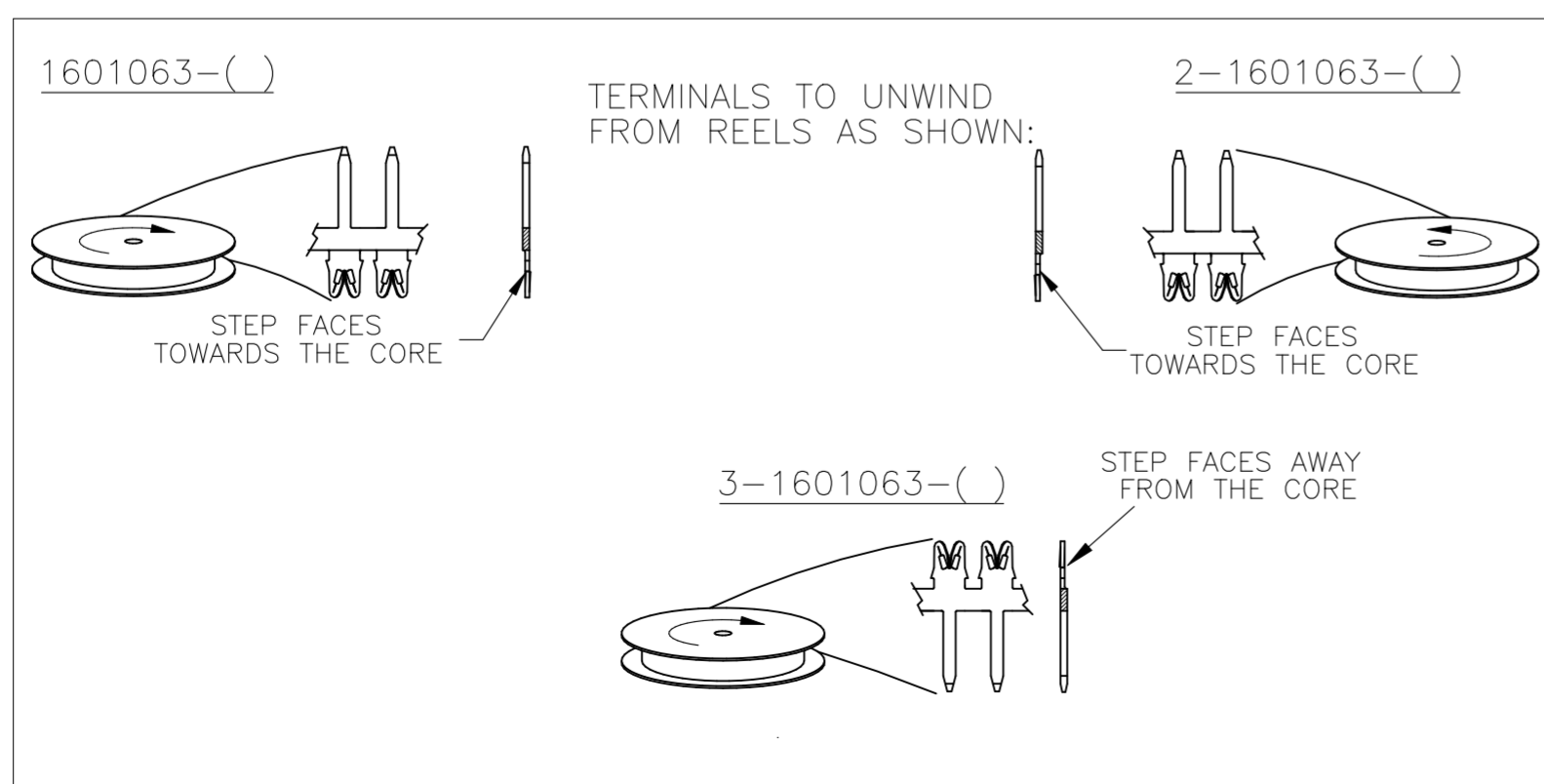
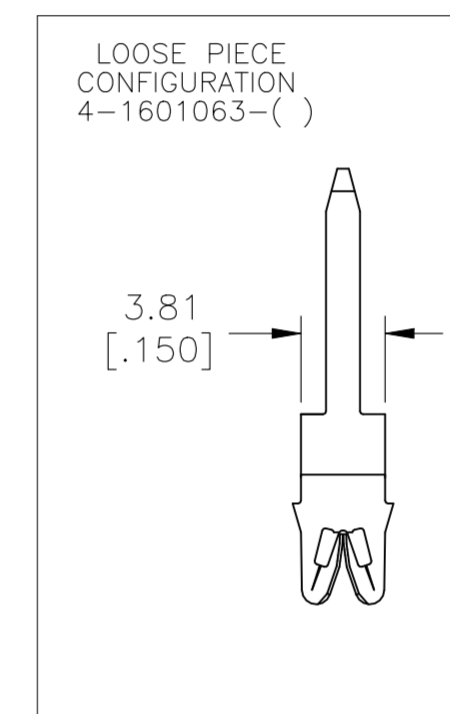
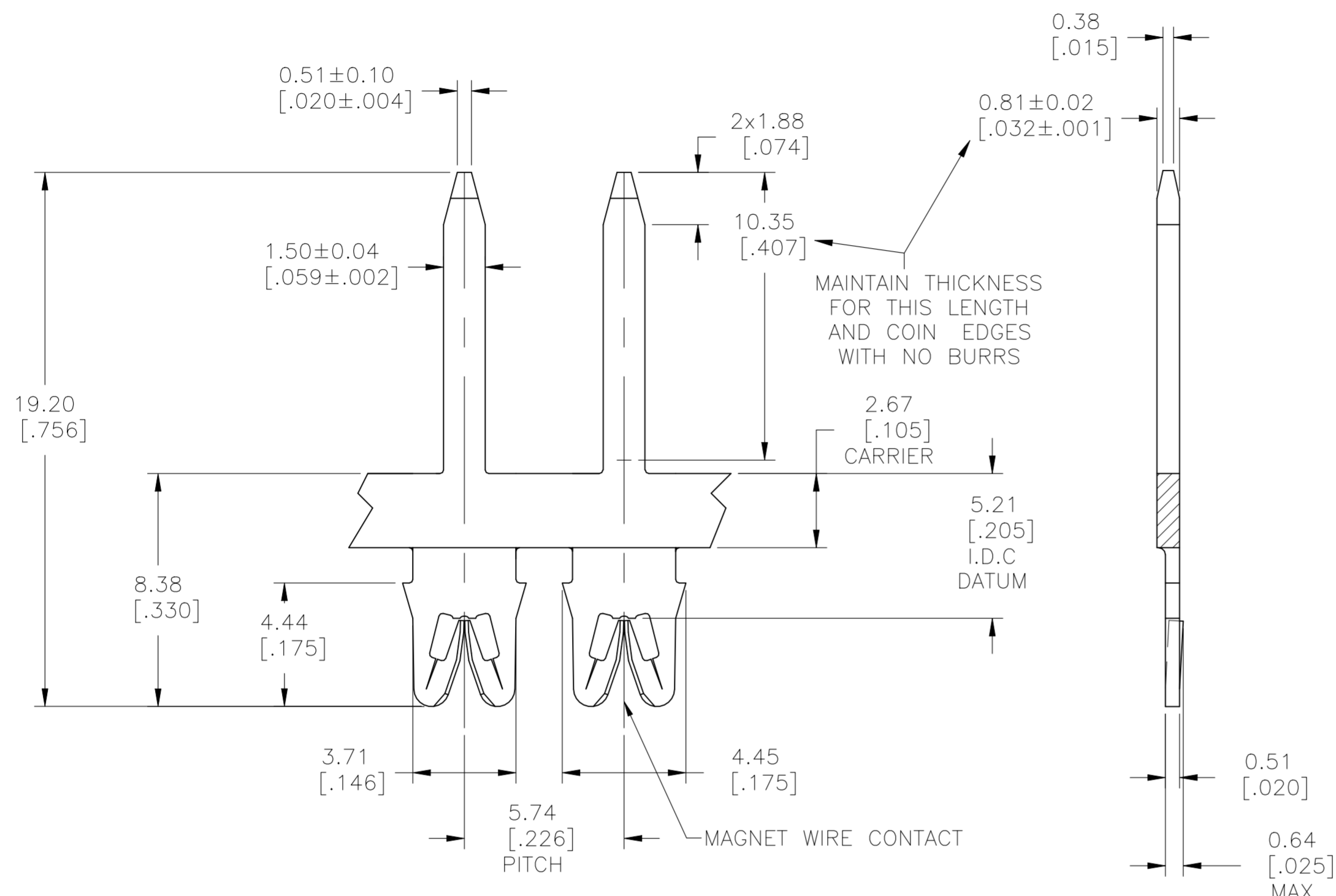

	POST TIN PLATE	-	1601063-4
	PRE TIN PLATE	-	3-1601063-2
	POST TIN OVER NICKEL	-	4-1601063-3
	POST TIN OVER NICKEL	-	1601063-3
5	OBSOLETE	031-129-021	4-1601063-2
	PRE TIN PLATE	131-130-021	2-1601063-2
	PRE TIN PLATE	131-129-021	1601063-2
	FINISH	REFERENCE PART NUMBER	TE PART NUMBER
THIS DRAWING IS A CONTROLLED DOCUMENT.		DWN J.WELLER 11JAN2002	 TE Connectivity
DIMENSIONS: mm [INCHES]		CHK M.FEHER 11JAN2002	
TOLERANCES UNLESS OTHERWISE SPECIFIED:		APVD K.RANDOLPH 11JAN2002	
0 PLC ± - 1 PLC ± - 2 PLC ± 0.13[.005] 3 PLC ± - 4 PLC ± - ANGLES ± 2°		NAME PRODUCT SPEC 108-2085 APPLICATION SPEC	
MATERIAL	FINISH	WEIGHT	SIZE
BRASS, 3/4 HARD	SEE TABLE	0.000000	A2
CUSTOMER DRAWING		CAGE CODE	DRAWING NO
		00779	C=1601063
		SCALE	SHEET
		6:1	1 of 1
		REV	E2

单击下面可查看定价，库存，交付和生命周期等信息

[>>TE Connectivity\(泰科\)](#)