

THIS DRAWING IS UNPUBLISHED. RELEASED FOR PUBLICATION
 © COPYRIGHT - By - ALL RIGHTS RESERVED.

LOC		DIST		REVISIONS			
P	LTR	DESCRIPTION	DATE	DWN	APVD		
AF	50	E	REVIS PER ECR-12-013486	10JAN13	KH	KR	

SUGGESTED MATING TAB

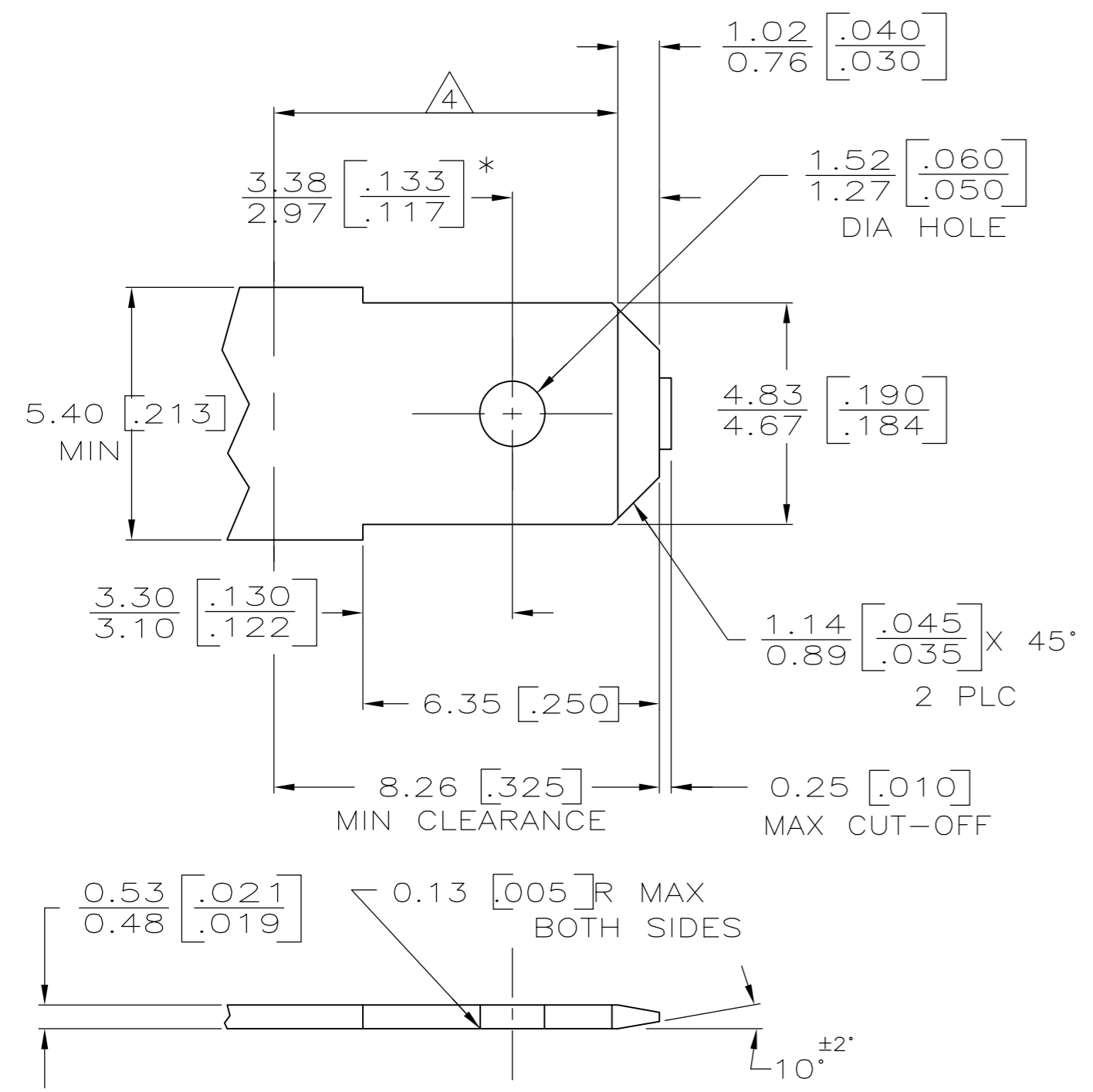

- 1 MATL: #2 HARD BRASS OR NICKEL PLATE STEEL.
 - 2 NO BURRS PERMISSIBLE AT HOLE.
 - 3 TIN PLATING IS REQUIRED ON BRASS WHEN TERMINAL TEMPERATURE IS OVER 225°F
 - 4 MUST BE FLAT WITHIN 0.076 [.003] OVER THIS LENGTH.
 - 5 HOLE MUST BE SYMMETRICAL ABOUT TAB ϕ WITHIN 0.076 [.003].
- * TO BE USED ONLY WHEN SHOULDER IS ELIMINATED.

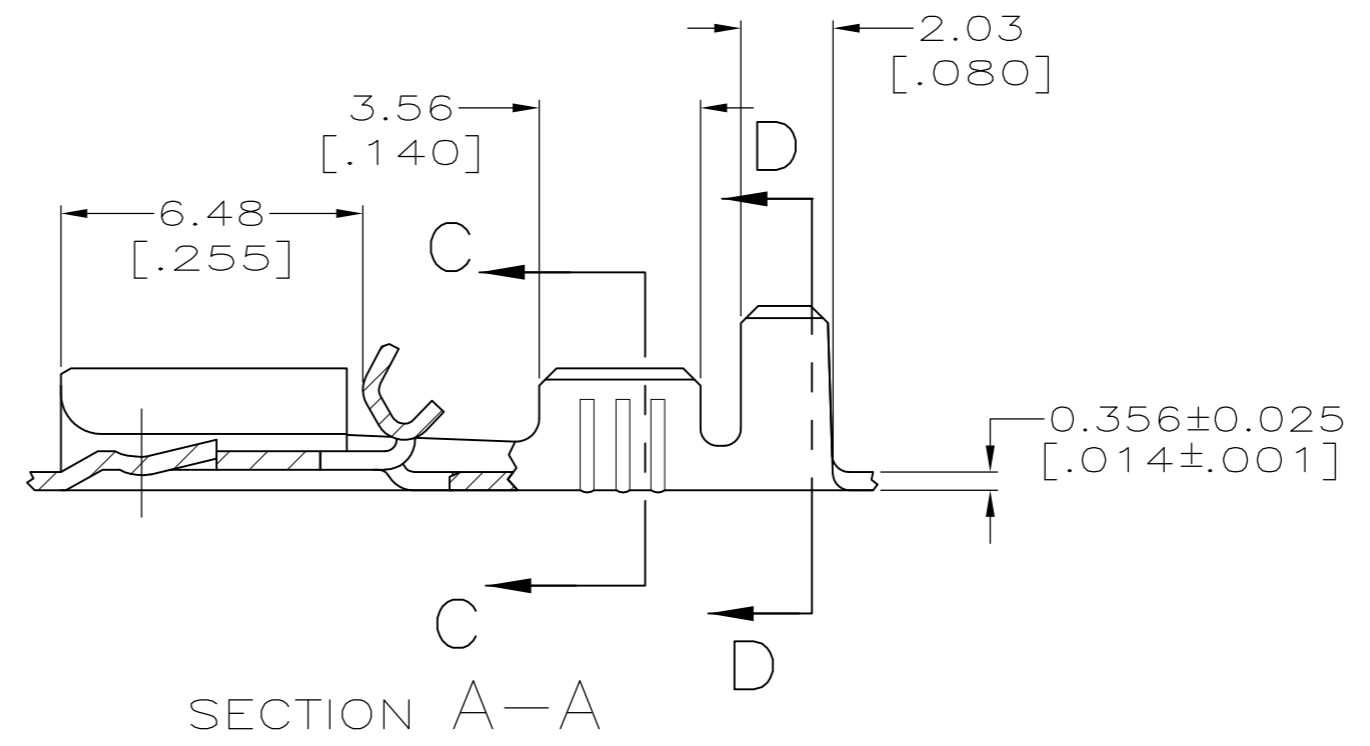
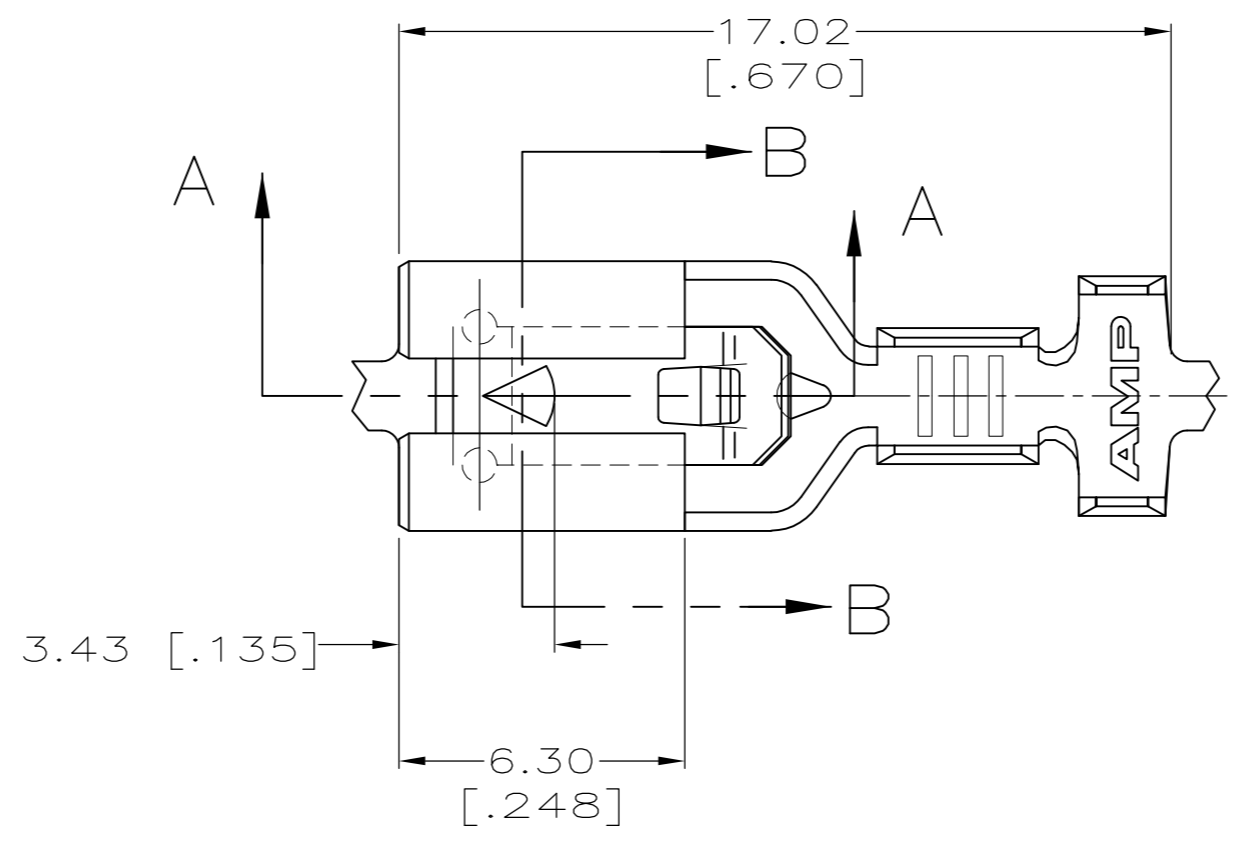

- 1 CONTINUOUS STRIP ON REELS.
- 2 ACCEPTS #22-#18 SINGLE WIRE SIZES, WIRE CRIMP IS 2.03 [.080], F TYPE.
- 3 FITS INSULATION RANGE 2.29-3.30 [.090-.130] DIA, INSULATION CRIMP IS 3.94 [.155] F TYPE.

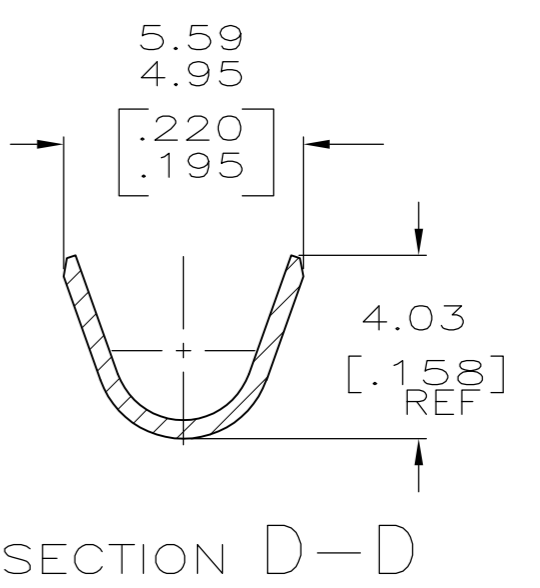
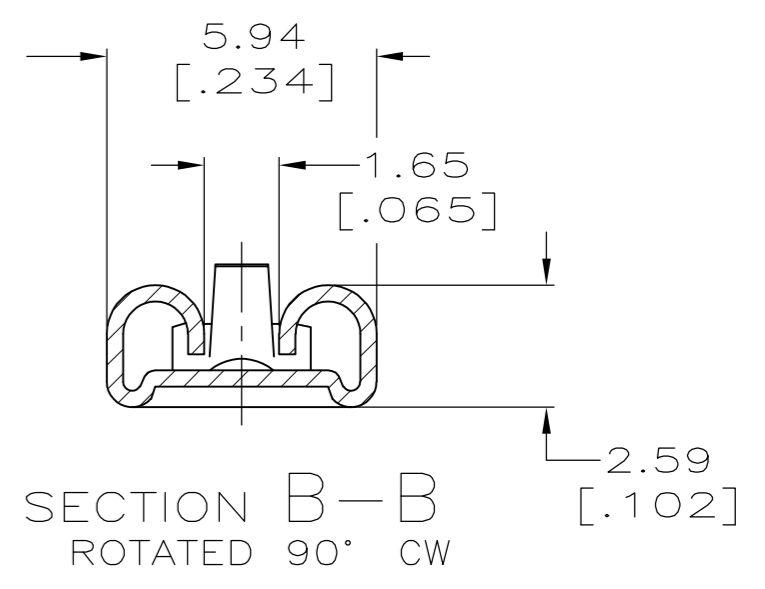

TIN	1217113-2
-	1217113-1
FINISH	PART NO.

THIS DRAWING IS A CONTROLLED DOCUMENT.		DWN	JR RUTH	9/17/98
DIMENSIONS: mm [INCHES]		CHK	MS FEHER	9/17/98
TOLERANCES UNLESS OTHERWISE SPECIFIED:		APVD	E HOWARD	9/17/98
0 PLC	± -	PRODUCT SPEC		
1 PLC	± -	APPLICATION SPEC		
2 PLC	± 0.25 [.010]			
3 PLC	± -			
4 PLC	± -			
ANGLES	± -			
MATERIAL	FINISH	WEIGHT		
BRASS	SEE TABLE	-		
		CUSTOMER DRAWING	SCALE	6:1
			SHEET	1 OF 1
			REV	E

TE Connectivity	
RECEPTACLE, POSITIVE-LOCK, MARK III, 4.75 [.187] SERIES	
SIZE	A2
CAGE CODE	00779
DRAWING NO	C=1217113
RESTRICTED TO	-

单击下面可查看定价，库存，交付和生命周期等信息

[>>TE Connectivity\(泰科\)](#)