

REVISIONS					
P.	LTN	DESCRIPTION	DATE	DMN	APVD
A18	ECR-16-006173		04MAY2016	MB	JK
A19	ECR-16-009404		22SEP2016	MB	JK
A20	ECR-17-005648		21OCT2017	MB	PSI
A21	ECR-18-014391		24SEP2018	SCK	RP

CONTACTS FOR FLR-CABLE  
 Kontakte fuer FLR-Leitung

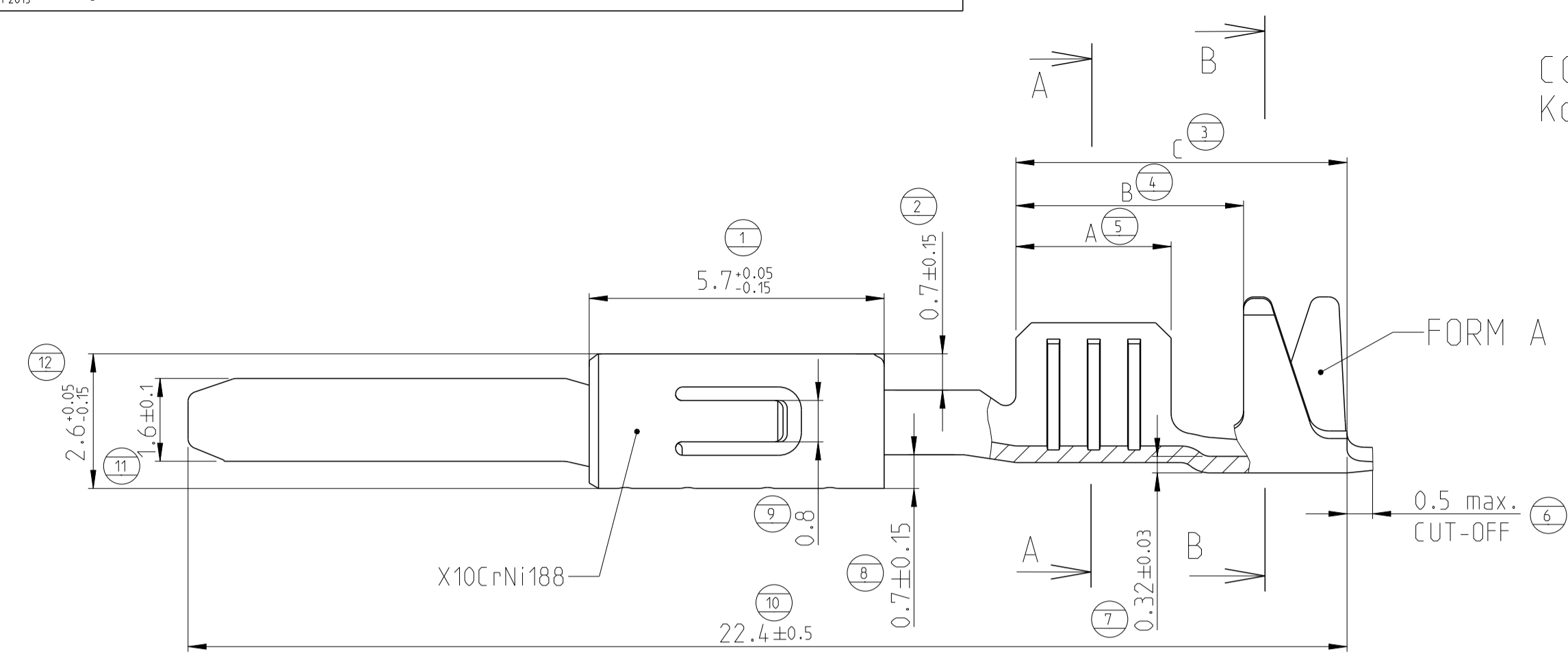

DESIGN 963898 / 963900 / 963904  
 Ausfuehrung 963898 / 963900 / 963904

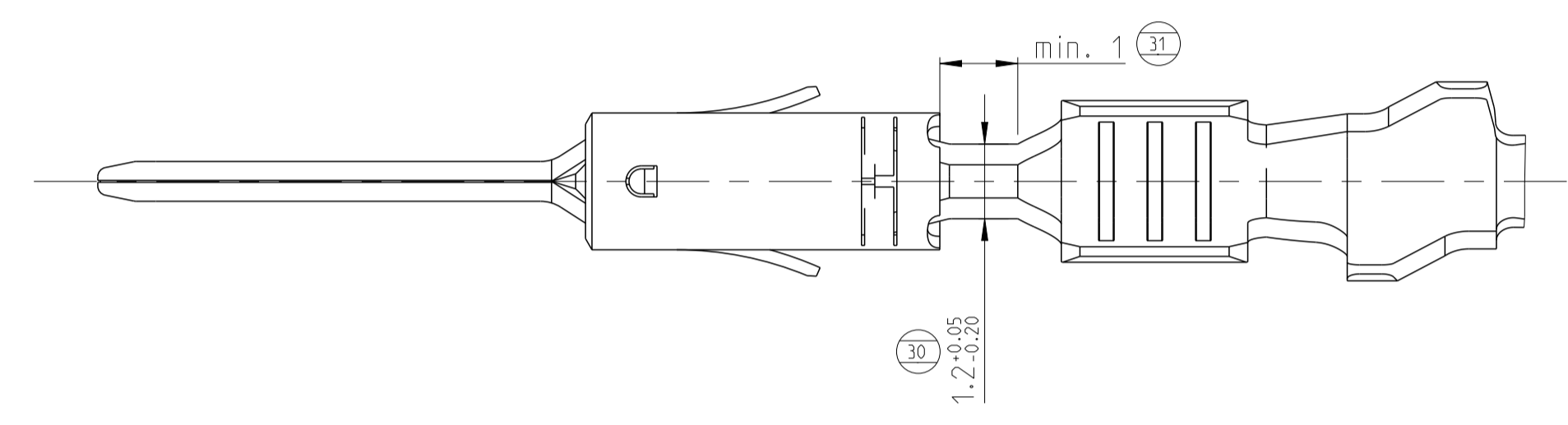
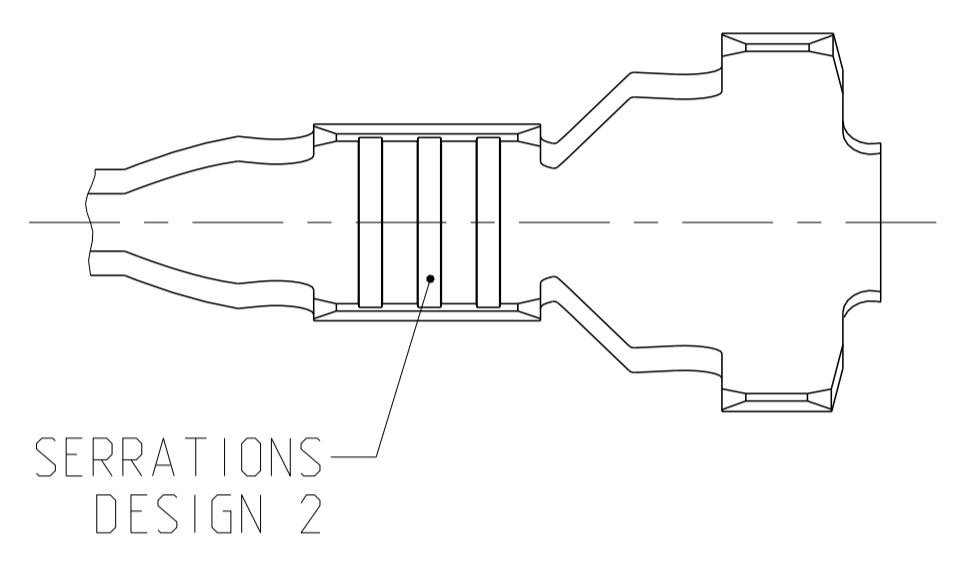
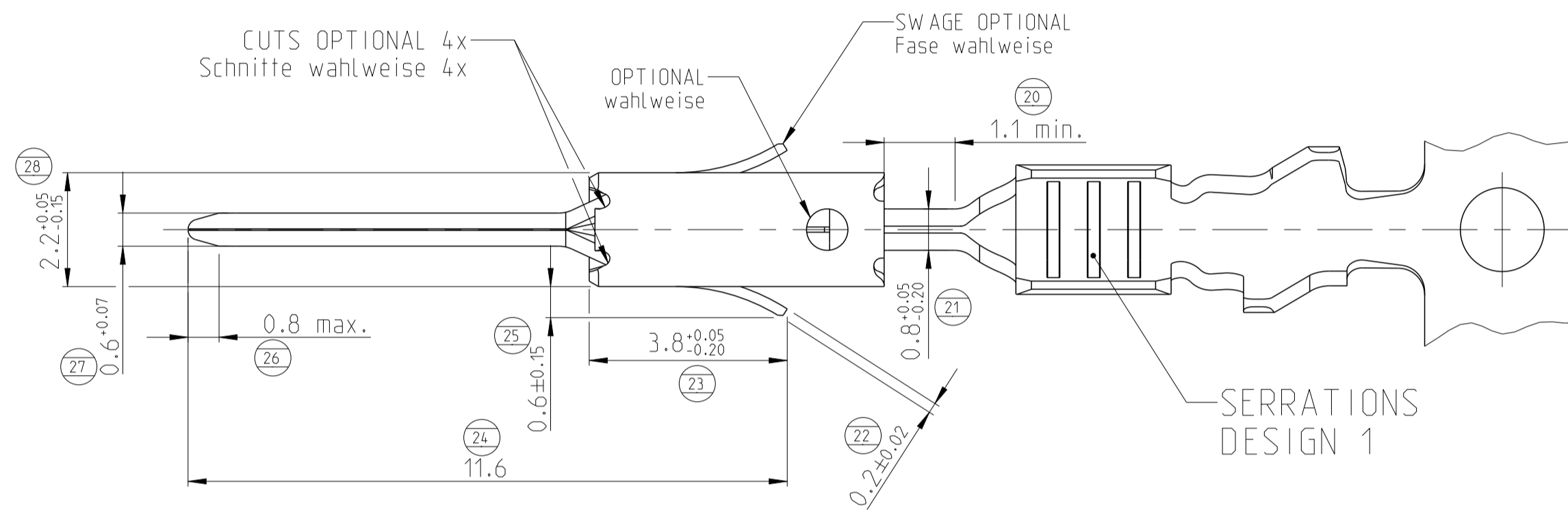
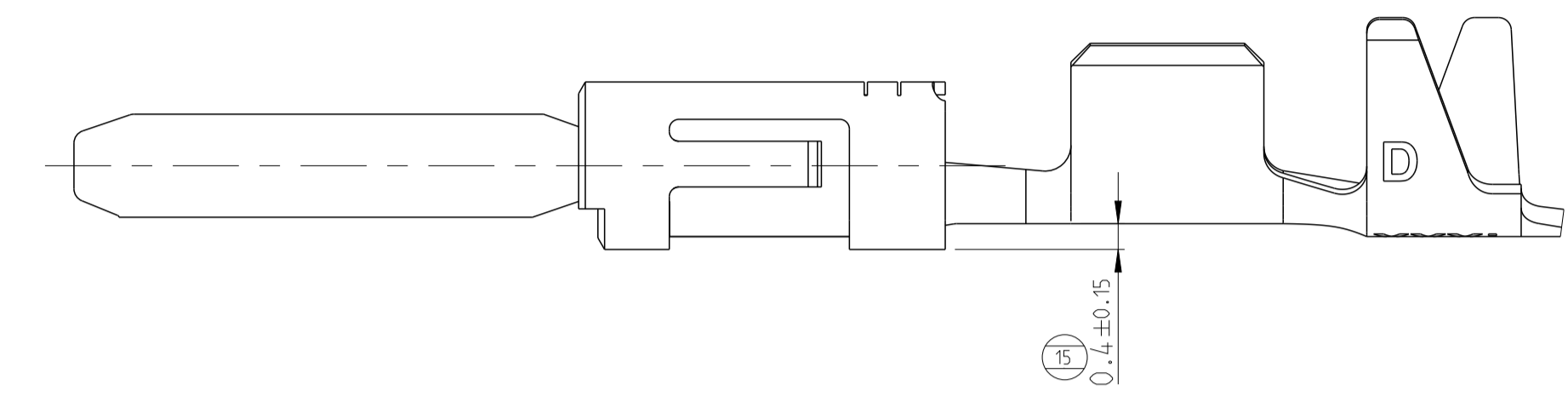

CONTACTS FOR SINGLE WIRE SEALING SYSTEM:  
 FLR- AND FLK-CABLE  
 Kontakte fuer Einzeldichtung-System:  
 FLR- und FLK-Leitung

DIMENSIONS SEE FIGURE CONTACTS FOR FLR-CABLE  
 Masse siehe Darstellung der Kontakte fuer FLR-Leitung

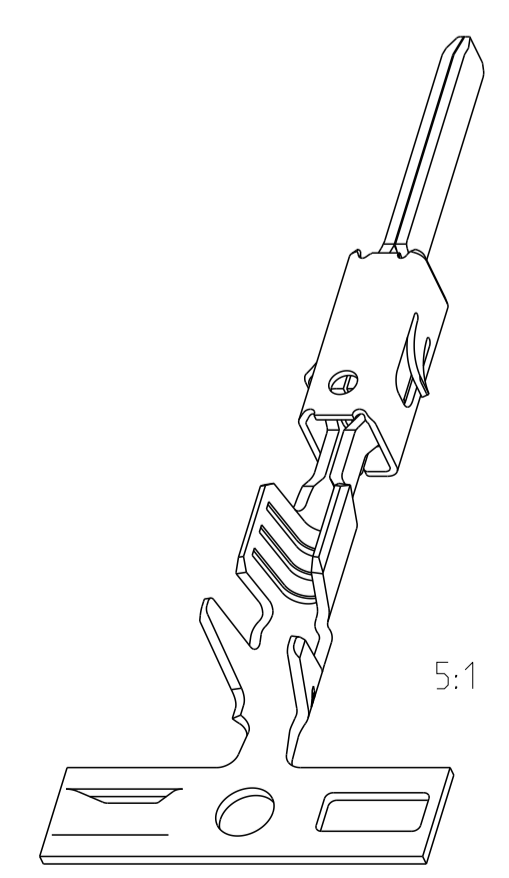
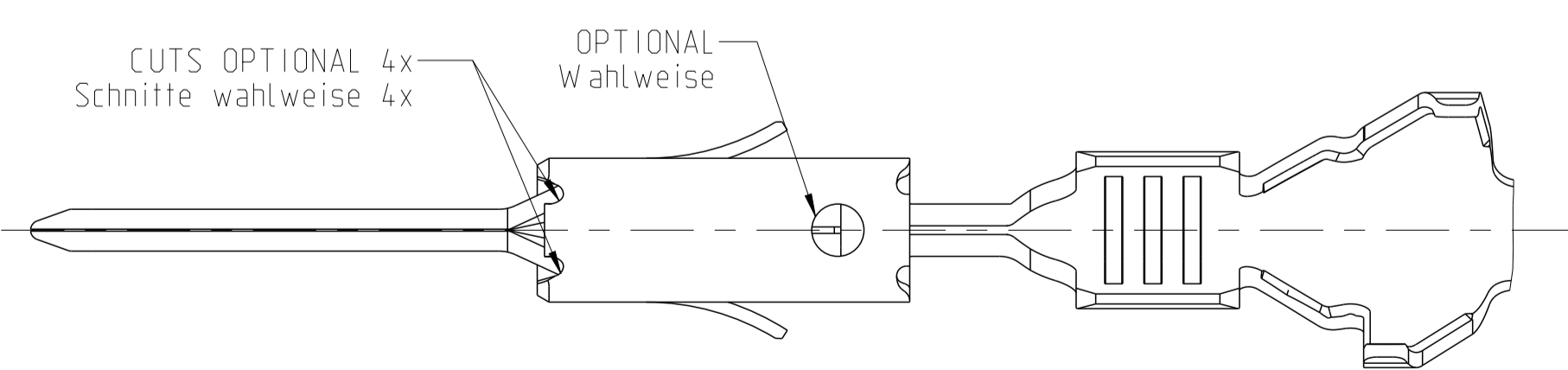
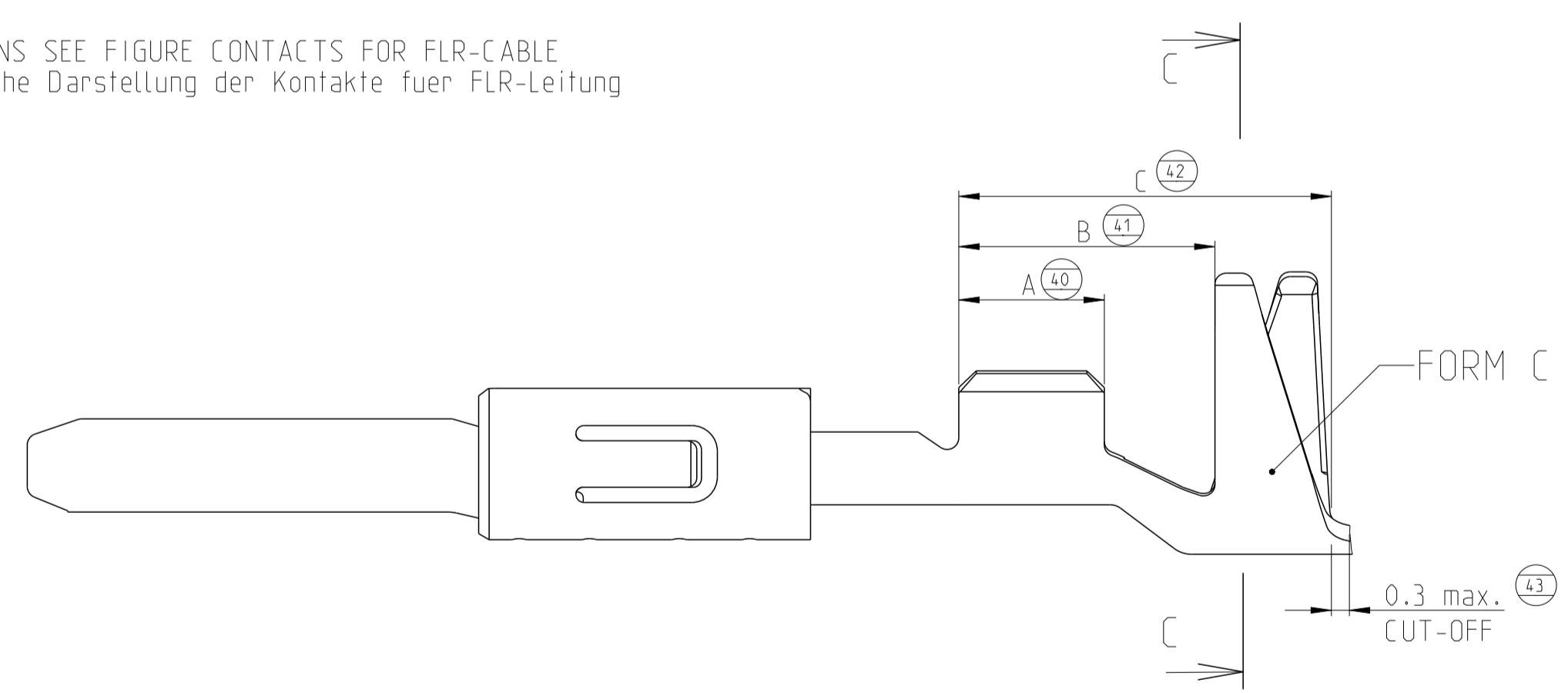

DESIGN 963902  
 Ausfuehrung 963902

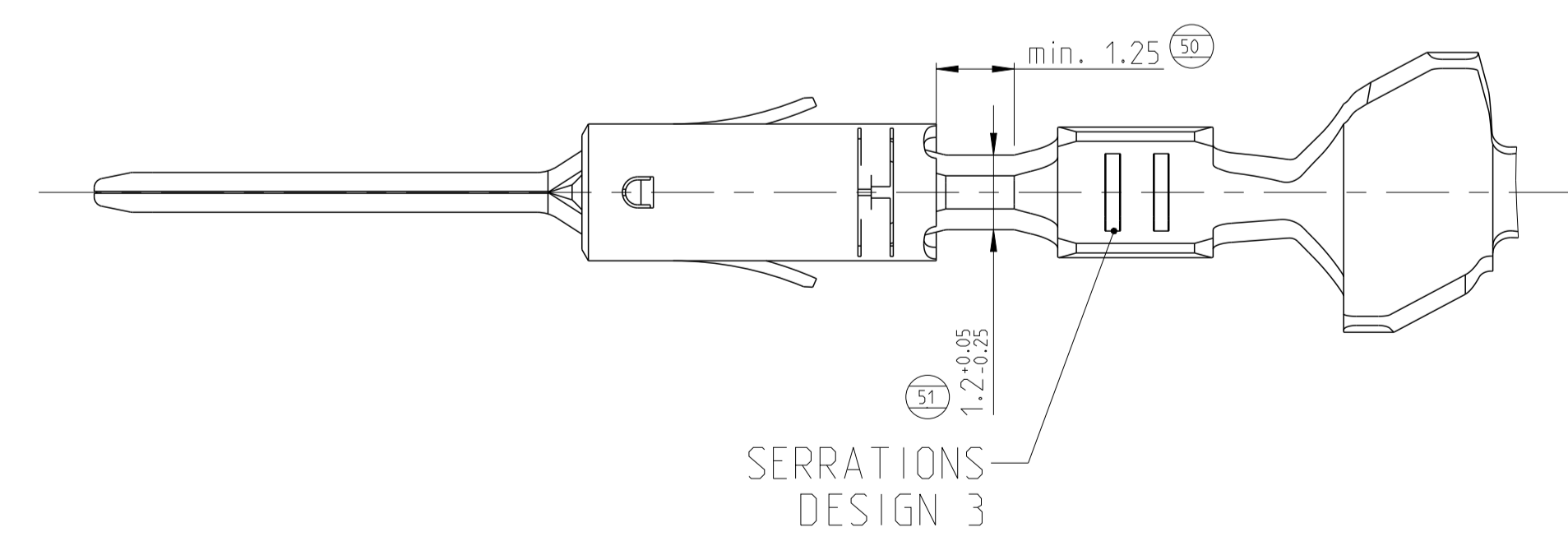
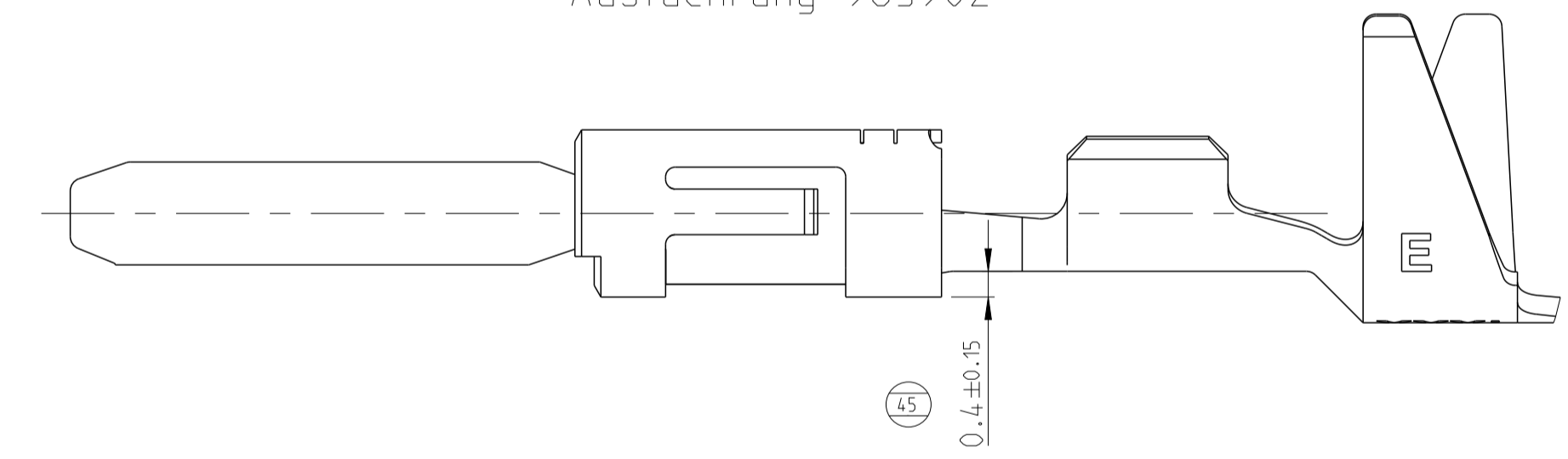

SERRATIONS DESIGN 3

THIS DRAWING IS A CONTROLLED DOCUMENT.		DMN T. Bensch 11JUN1997	11JUN1997	TE Connectivity
DIMENSIONS: mm		CHK U. Muenk 11JUN1997	11JUN1997	
TOLERANCES UNLESS OTHERWISE SPECIFIED: mm		APVD M. Bleicher 02MAR2011	02MAR2011	NAME PRODUCT GROUP DRAWING TAB 1.6 x 0.6 Flachstecker 1.6 x 0.6
1-PLC ±0.2 2-PLC ±0.2 3-PLC ±0.2 ANGLES ±0.2 FINISH ±0.2		PRODUCT SPEC 108-18331 APPLICATION SPEC 114-18082	SIZE CAGE CODE DRAWING NO 00779 ©=1355055	
MATERIAL SEE TABLE sheet 2 siehe Tabelle		WEIGHT -	CUSTOMER DRAWING	RESTRICTED TO
SCALE 10:1		SHEET 1 OF 2		REV A21

REVISIONS				
P.	LTN	DESCRIPTION	DATE	APPV
-	-	SEE SHEET 1	-	-

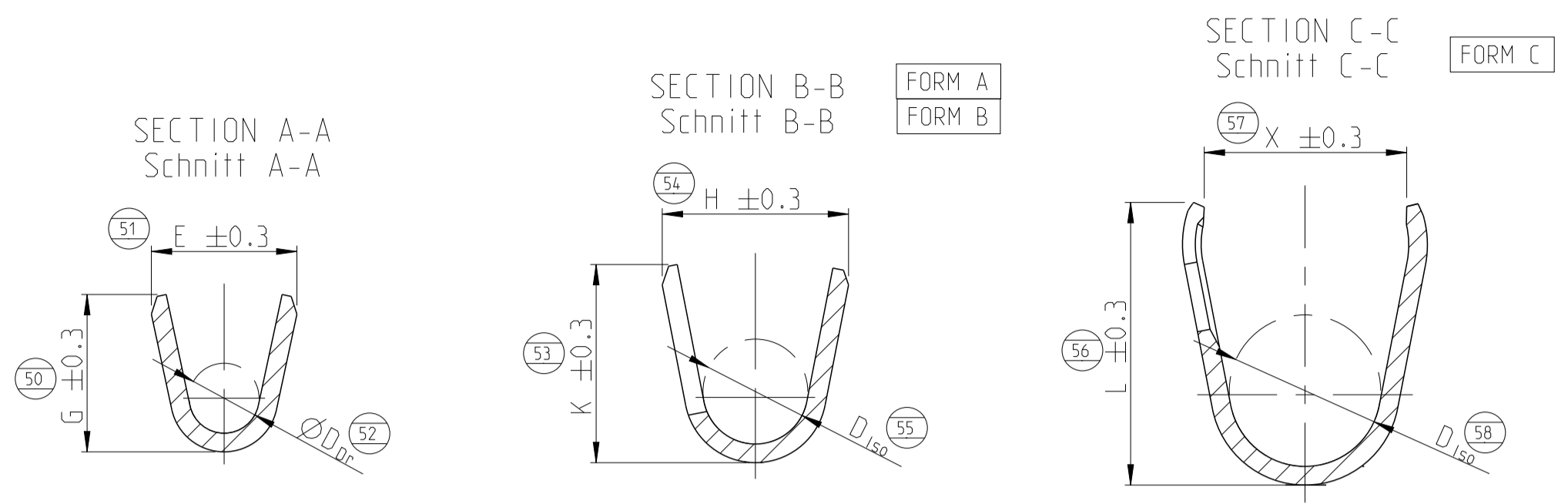

SINGLE WIRE SEAL / Einzelichtungssystem	TE ORDER-NO.	REV	DESIGN SERRATIONS Ausführung Serrations	MATERIAL Werkstoff	SURFACE Oberfläche	DGB mm <sup>2</sup>	INSULATION IsolationsØ mm	SEE / siehe SECTION A-A Schnitt A-A	SEE / siehe SECTION B-B / C-C Schnitt B-B / C-C	HAND TOOL Handzange	INSERT Matrize	A	B	C	X	TE ORDER-NO.	CRIMP DATA AND CRIMP TOOL Crimpdaten und Crimpwerkzeuge									
								E = 2.8 G = 3.0 D <sub>Dr</sub> = 1.4	L = 4.9 D <sub>ISO</sub> = 2.9																	
UNSEALED / ungedichtet	1703278-5	A	1	CuSn4	5	1.5	1.95 - 2.4	E = 2.8 G = 3.0 D <sub>Dr</sub> = 1.4	L = 4.9 D <sub>ISO</sub> = 2.9	169400-0 539635-1	539960-1	-	3.0	4.4	6.4	3.6	SEE APPLICATION SPECIFICATION 114-18082 siehe Verarbeitungsspezifikation 114-18082									
	1703278-2	A	1	CuFe2	4	0.5 - 1.0	1.4 - 2.1	E = 2.5 G = 2.7 D <sub>Dr</sub> = 1.2	L = 4.8 D <sub>ISO</sub> = 2.7									539612-1 539663-2	3.0	4.4	6.4	3.3	-	-	-	
	2-964269-2	A	1	CuFe2	5																					
	964269-5	A	1	CuSn4	5	0.5 - 1.0	1.4 - 2.1	E = 2.6 G = 2.8 D <sub>Dr</sub> = 1.2	H = 4.5 K = 4.8 D <sub>ISO</sub> = 2.7									539651-2	3.0	4.6	7.0	-	-	-	-	
	964269-3	E	1	CuSn4	1																					
	964269-2	D	1	CuFe2	4																					
	963904-3	G	1	CuSn4	1	0.35	1.15 - 1.6	E = 2.4 G = 2.3 D <sub>Dr</sub> = 1.0	L = 4.8 D <sub>ISO</sub> = 2.6									539663-2	2.5	4.4	6.4	3.3	-	-	-	-
	963904-2	F	1	CuFe2	4																					
	963904-1	F	1	CuSn4	4																					
	2141884-5	A	2	CuSn4	5	0.2 - 0.5	1.15 - 1.6	E = 2.1 G = 2.1 D <sub>Dr</sub> = 0.8	X = 4.3 L = 4.8 D <sub>ISO</sub> = 2.6									539612-1 539663-2	2.5	4.4	6.4	3.3	-	-	-	-
	2141884-3	B	2	CuSn4	1																					
	2-2141884-2	A	2	CuFe2	5																					
	2141884-2	A	2	CuFe2	4	0.2 - 0.5	1.15 - 1.6	E = 2.1 G = 2.1 D <sub>Dr</sub> = 0.8	H = 4.5 K = 4.8 D <sub>ISO</sub> = 2.7									539651-2	2.5	4.6	7.0	-	-	-	-	-
	969028-5	A	3	CuSn4	5																					
	969028-3	E	3	CuSn4	1																					
	969028-2	D	3	CuFe2	4	1.5	2.2 - 2.4	E = 2.1 G = 2.1 D <sub>Dr</sub> = 0.8	H = 4.5 K = 4.8 D <sub>ISO</sub> = 2.7									539651-2	2.5	4.6	7.0	-	-	-	-	-
	963902-3	E	3	CuSn4	1																					
	963902-2	D	3	CuFe2	4																					
963902-1	D	3	CuSn4	4	0.5 - 1.0	1.4 - 2.1	E = 2.5 G = 2.8 D <sub>Dr</sub> = 1.2	H = 3.7 K = 3.9 D <sub>ISO</sub> = 1.8	539612-1 539663-2	3.0	4.4	6.4	-	-	-	-	-									
1241846-5	A	1	CuSn4	5																						
1241846-3	B	1	CuSn4	1																						
1241846-2	A	1	CuFe2	4	0.5 - 1.0	1.4 - 2.1	E = 2.5 G = 2.7 D <sub>Dr</sub> = 1.2	H = 3.2 K = 3.4 D <sub>ISO</sub> = 1.8	539612-1 539663-2	3.0	4.4	6.4	-	-	-	-	-									
1241846-1	A	1	CuSn4	4																						
969079-3	C	1	CuSn4	1																						
969079-2	B	1	CuFe2	4	0.5 - 1.0	1.4 - 2.1	E = 2.6 G = 2.8 D <sub>Dr</sub> = 1.2	H = 3.2 K = 3.4 D <sub>ISO</sub> = 1.8	539651-2	3.0	4.6	7.0	-	-	-	-	-									
964267-4	A	1	CuSn4	5																						
964267-3	D	1	CuSn4	1																						
964267-2	C	1	CuFe2	4	0.2 - 0.5	1.15 - 1.6	E = 2.1 G = 2.1 D <sub>Dr</sub> = 0.8	H = 2.9 K = 2.9 D <sub>ISO</sub> = 1.4	539651-2	2.5	4.6	7.0	-	-	-	-	-									
964267-1	C	1	CuSn4	4																						
963900-4	E	1	CuSn4	1																						
963900-3	E	1	CuSn4	1	0.2 - 0.35	1.15 - 1.6	E = 2.4 G = 2.3 D <sub>Dr</sub> = 1.0	H = 2.9 K = 2.9 D <sub>ISO</sub> = 1.4	539633-2	2.5	4.4	6.4	-	-	-	-	-									
963900-2	D	1	CuFe2	4																						
963900-1	D	1	CuSn4	4																						
963898-3	E	3	CuSn4	1	0.2 - 0.35	1.15 - 1.6	E = 2.1 G = 2.1 D <sub>Dr</sub> = 0.8	H = 2.9 K = 2.9 D <sub>ISO</sub> = 1.4	539612-1 539663-2	2.5	4.4	6.4	-	-	-	-	-									
963898-2	D	3	CuFe2	4																						
963898-1	D	3	CuSn4	4																						
2141882-3	B	2	CuSn4	1	0.2 - 0.35	1.15 - 1.6	E = 2.1 G = 2.1 D <sub>Dr</sub> = 0.8	H = 2.9 K = 2.9 D <sub>ISO</sub> = 1.4	539612-1 539663-2	2.5	4.4	6.4	-	-	-	-	-									
2141882-2	A	2	CuFe2	4																						
964265-5	A	3	CuSn4	5																						
964265-3	D	3	CuSn4	1	0.2 - 0.35	1.15 - 1.6	E = 2.1 G = 2.1 D <sub>Dr</sub> = 0.8	H = 2.9 K = 2.9 D <sub>ISO</sub> = 1.4	539612-1 539663-2	2.5	4.4	6.4	-	-	-	-	-									
964265-2	C	3	CuFe2	4																						

- 1 CONTACT AREA SELECTIVE GOLD 0.8µm MIN. OVER NICKEL.  
WIRE CRIMP AREA ELECTRO TIN PLATED 1µm MIN. OVER NICKEL  
Kontaktzone selectiv vergoldet 0.8µm min. ueber Ni  
Drahtcrimpbereich gal. verzinkt 1µm min. ueber Ni
- 2 FOR DOUBLE- AND SINGLE TERMINATION fuer Doppel- und Einzelanschlaege
- 3 SINGLE WIRE SEAL TO BE SELECTED ACCORDING TO INSULATION-DIA ACCODING TO APPLICATION SPECIFICATION 114-18082  
Auswahl der Eubzeldichtung entsprechend dem Isolationsdurchmesser nach Verarbeitungsspezifikation 114-18082
- 4 TIN PLATED vorverzinkt
- 5 CONTACT AREA SELECTIVE SILVER 3µm MIN. OVER NICKEL.  
WIRE CRIMP AREA ELECTRO TIN PLATED 1.5µm MIN. OVER NICKEL  
Kontaktzone selectiv versilbert 3µm min. ueber Ni  
Drahtcrimpbereich gal. verzinkt 1.5µm min. ueber Ni
- 6 DIFFERENT TOOL DETAILS FUNCTION AND HANDLING WITH ALL DETAILS CONTINUOUSLY SUPPLY AFTER AVAILABILITY  
Verschiedene Werkzeugausfuehrungen Funktion und Handhabung bei allen Ausfuehrungen gleich Lieferung nach Verfuegbarkeit

TE ORDER-NO.	REV	DESIGN SERRATIONS Ausführung Serrations	MATERIAL Werkstoff	SURFACE Oberfläche	DGB mm <sup>2</sup>	INSULATION IsolationsØ mm	STRIP FORM WIRE CRIMP Drahtcrimp INSUL. CRIMP Isolationscrimp Bandware	HAND TOOL Handzange	INSERT Matrize	A	B	C	X	TE ORDER-NO.	CRIMP DATA AND CRIMP TOOL Crimpdaten und Crimpwerkzeuge
							CRIMP DIMENSION mm Crimpabmessungen mm								

THIS DRAWING IS A CONTROLLED DOCUMENT.

DIMENSIONS: mm	TOLERANCES UNLESS OTHERWISE SPECIFIED: ±0.2	OWN: T. Bertsch 11JUN1997	TE Connectivity
MATERIAL: SEE TABLE sheet 2 siehe Tabelle	FINISH: SEE TABLE sheet 2 siehe Tabelle	CHK: U. Muenk 11JUN1997	APV: M. Bleicher 02MAR2011
CUSTOMER DRAWING		SIZE: A1	SCALE: 10:1
CAGE CODE: 00779		DRAWING NO: 114-18082	SHEET: 2 OF 2

PRODUCT GROUP DRAWING  
 TAB 1.6 x 0.6 TYPE A  
 Flachsfecker 1.6 x 0.6 Typ A

单击下面可查看定价，库存，交付和生命周期等信息

[>>TE Connectivity\(泰科\)](#)