

THIS DRAWING IS UNPUBLISHED. RELEASED FOR PUBLICATION
 © COPYRIGHT - By - ALL RIGHTS RESERVED.

LOC		DIST		REVISIONS			
P	LTR	DESCRIPTION		DATE	DWN	APVD	
CM	00	D1	REVISED PER ECO 12-010618		06JUN12	JR	TM

1 MATERIAL: HOUSING: POLYAMIDE, UL94V-2, WHITE
 CONTACTS: BRASS, TIN-PLATED

- 2 FLAMMABILITY V2 FOR THICKNESS 0.38mm, 1.5mm, and 3.0mm PER IEC 60695-11-10.
- 3 GLOW-WIRE FLAMMABILITY (GWFI) 800°C FOR THICKNESS 0.38mm AND 0.75mm PER IEC 60695-2-12.
- 4 GLOW-WIRE FLAMMABILITY (GWFI) 960°C FOR THICKNESS 1.5mm AND 3.0mm PER IEC 60695-2-12.
- 5 GLOW-WIRE IGNITION (GWIT) 825°C FOR THICKNESS 0.38mm, 0.75mm, 1.5mm AND 3.0mm PER IEC 60695-2-13.

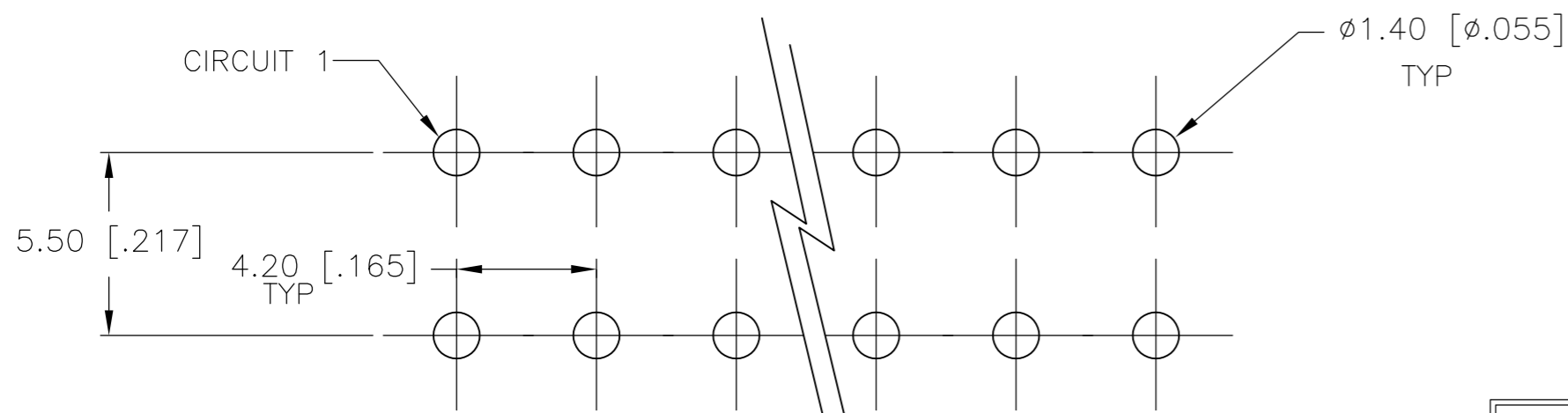
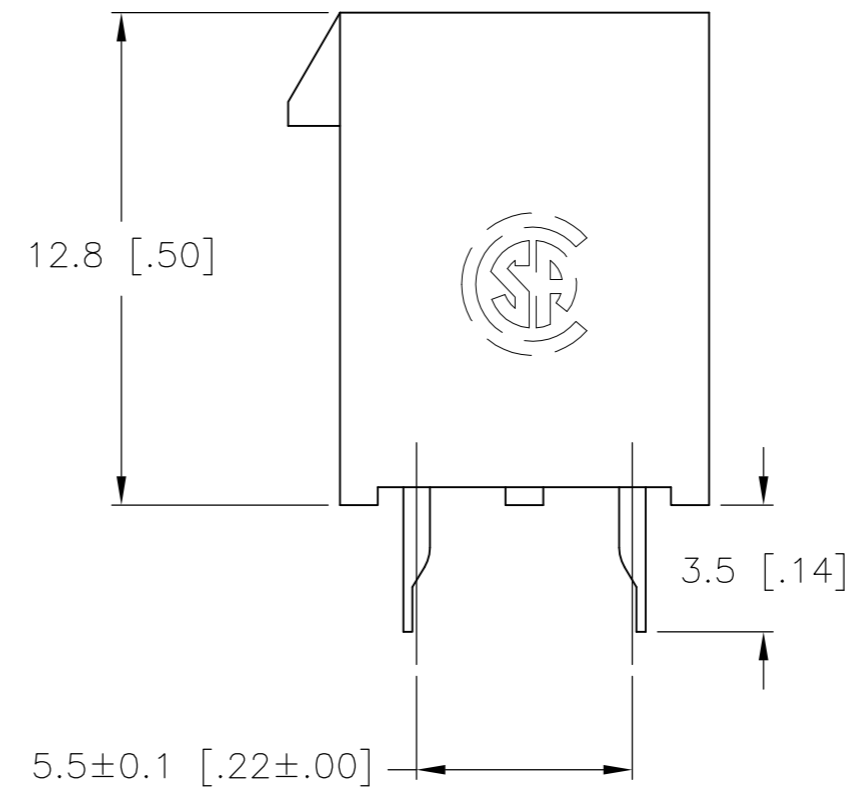
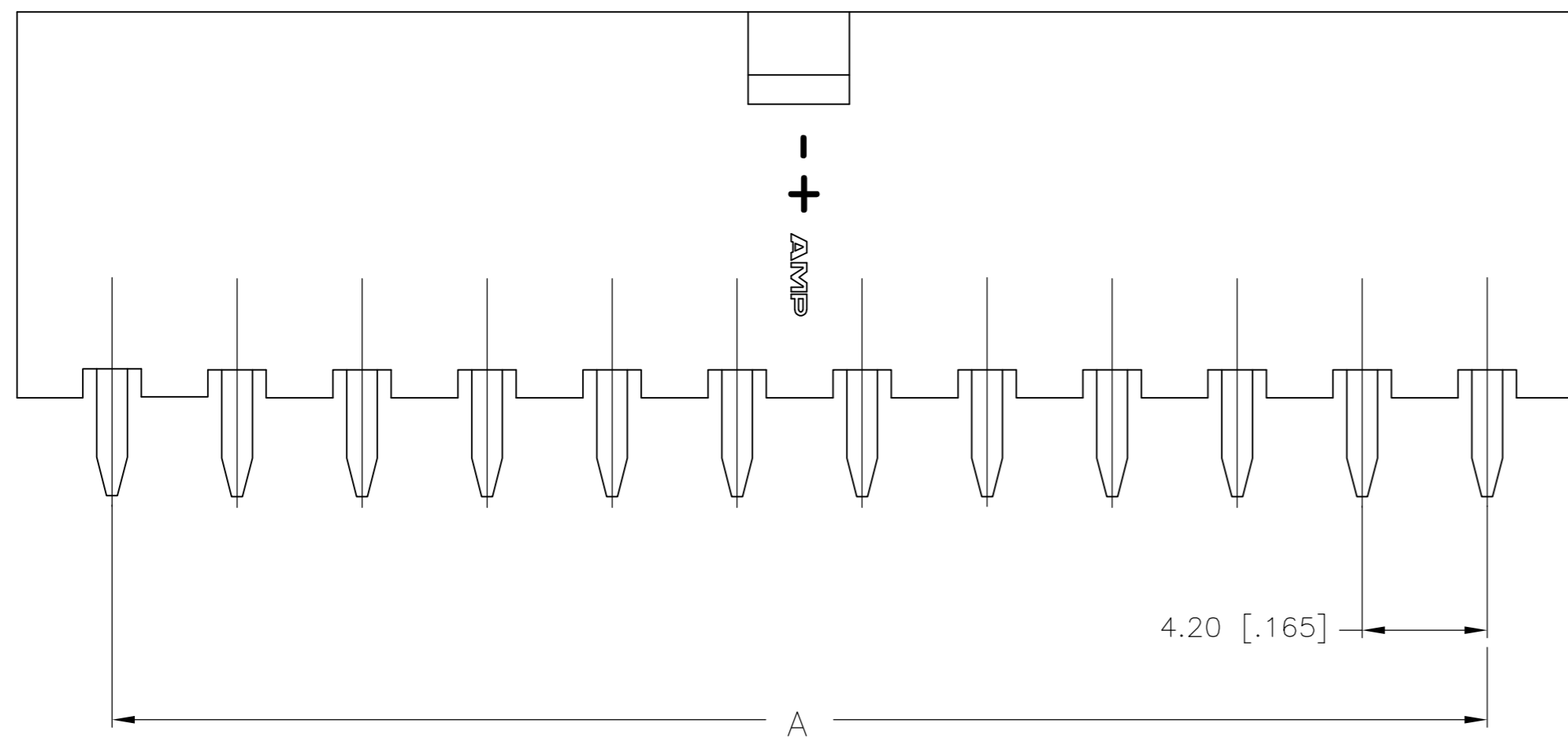
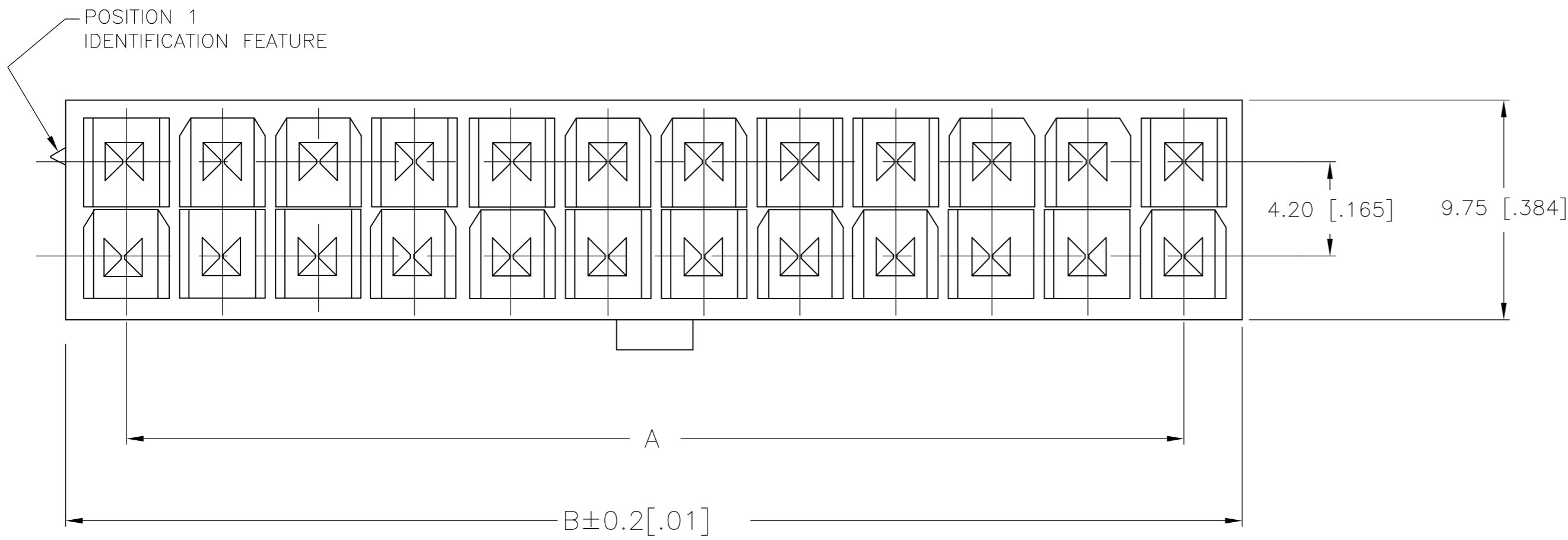

24	46.2±0.2 [1.82±.01]	51.6 [2.03]	2-1586768-4
22	42.0±0.2 [1.65±.01]	47.4 [1.87]	2-1586768-2
20	37.8±0.2 [1.49±.01]	43.2 [1.70]	2-1586768-0
18	33.6±0.2 [1.32±.01]	39.0 [1.54]	1-1586768-8
16	29.4±0.2 [1.16±.01]	34.8 [1.37]	1-1586768-6
14	25.2±0.2 [.99±.01]	30.6 [1.21]	1-1586768-4
12	21.0±0.2 [.83±.01]	26.4 [1.04]	1-1586768-2
10	16.8±0.1 [.66±.00]	22.2 [.87]	1-1586768-0
8	12.6±0.1 [.50±.00]	18.0 [.71]	1586768-8
6	8.4±0.1 [.33±.00]	13.8 [.54]	1586768-6
4	4.2±0.1 [.17±.00]	9.6 [.38]	1586768-4
2		5.4 [.21]	1586768-2
POS	A	B±0.2[.01]	PART NUMBER

2-1586768-4 SHOWN

THIS DRAWING IS A CONTROLLED DOCUMENT.		DWN K. WHITAKER	08MAY2007	 TE Connectivity	VERTICAL HEADER WITHOUT PEGS, WITH DRAIN HOLES VAL-U-LOK(TM)
DIMENSIONS: mm [INCHES]		CHK D. COLEY	C. CASH		
TOLERANCES UNLESS OTHERWISE SPECIFIED:		APVD C. CASH	08MAY2007		
0 PLC ± 1 PLC ± 2 PLC ± 0.5 [.02] 3 PLC ± 0.25 [.010] 4 PLC ± 0.150 [0059] ANGLES ±		APPLICATION SPEC			
MATERIAL	1	WEIGHT	A2	CAGE CODE	00779
CUSTOMER DRAWING		SCALE	10:1	DRAWING NO	C=1586768
		SHEET	1 of 1	RESTRICTED TO	-
		REV	D1		

METRIC

单击下面可查看定价，库存，交付和生命周期等信息

[>>TE Connectivity\(泰科\)](#)