

REVISIONS

P	LTR	DESCRIPTION	DATE	DWN	APVD
	D	New Drawing	22FEB2016	W I	GS
	D1	ECR-19-000210	09JAN2018	W I	GS

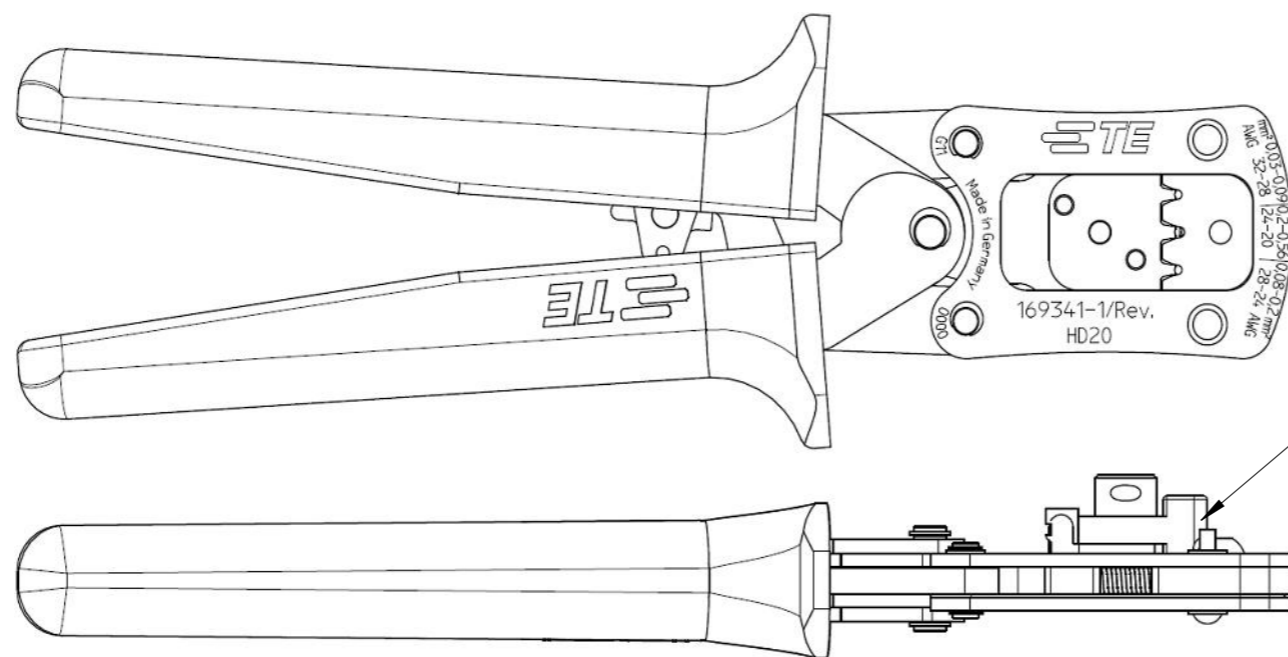

HAND TOOL HD20 0,03 - 0.56 SQMM



Kontaktpositionierer als Ersatzteil
erhaeltlich TE PN 4-539785-7
Contact locator as spare part
available TE PE 4-539785-7

Kontakt	Nest	Querschnitt	Drahtcrimp/Wire Crimp		Isolationscrimp/Insulation Crimp		Abisolierlänge	Isolat. Ø	Betriebsanleitung
Contact	Crimp Profile	Wire Size mm ²	Hoehe/Height mm	Breite/Width mm	Hoehe/Height mm	Breite/Width mm	Stripping Length (mm)	Insul. Ø	Instruction Sheet
166997 166998	1	0.03-0.09 AWG 32-28	0.53 ±0.05	0.84	1.20 ±0.1	1.40	2.15-2.65	1.3-1.5	411-19138
66504 66506	2	0.20-0.56 AWG 24-20	0.80 ±0.05	1.40	1.55 ±0.1	1.60	2.15-2.65	1.0 max.	
66505 66507	3	0.08-0.20 AWG 28-24	0.72 ±0.05	1.07	1.20 ±0.1	1.40	2.15-2.65	0.5-1.0	

Dimensions:
195x63x30 mm (LxW xH)

THIS DRAWING IS A CONTROLLED DOCUMENT.		DWN C.Witt 22FEB2016	 TE Connectivity		
DIMENSIONS: mm		CHK C.Witt 22FEB2016			
TOLERANCES UNLESS OTHERWISE SPECIFIED:		APVD G.Stegmayer 22FEB2016	NAME HAND TOOL HD20 HANDZANGE HD20		
		PRODUCT SPEC -	-		
MATERIAL		APPLICATION SPEC -	-		
FINISH		WEIGHT 280 g	SIZE A3	CAGE CODE 00779	DRAWING NO C-169341-1
-		CUSTOMER DRAWING	SCALE 1:1	SHEET 1 OF 1	REV D1

单击下面可查看定价，库存，交付和生命周期等信息

[>>TE Connectivity\(泰科\)](#)