

REVISIONS					
P	LTR	DESCRIPTION	DATE	DWN	APVD
J		REVISED PER ECR-17-015104	20AUG18	DZ	SL

NOTES:

- MATERIAL:**
 HOUSING: LCP WITH 30% GF, UL94 V-0, BLACK COLOR.
 CONTACTS: PHOSPHOR BRONZE.
 PEGS: BRASS.
- FINISH:**
 CONTACTS: (SEE TABLE) GOLD PLATED ON CONTACT AREA, GOLD FLASH ON SOLDER AREA, WITH ENTIRE CONTACT UNDERPLATED 1.27µm [50µ"] MIN. NICKEL.
 PEGS: 3.048µm [120µ"] MIN. MATTE-TIN OVER 1.27µm [50µ"] MIN. NICKEL.
- REFLOW SOLDER CAPABLE TO 260° PER TE TEST SPEC. 109-201, CONDITION B.**

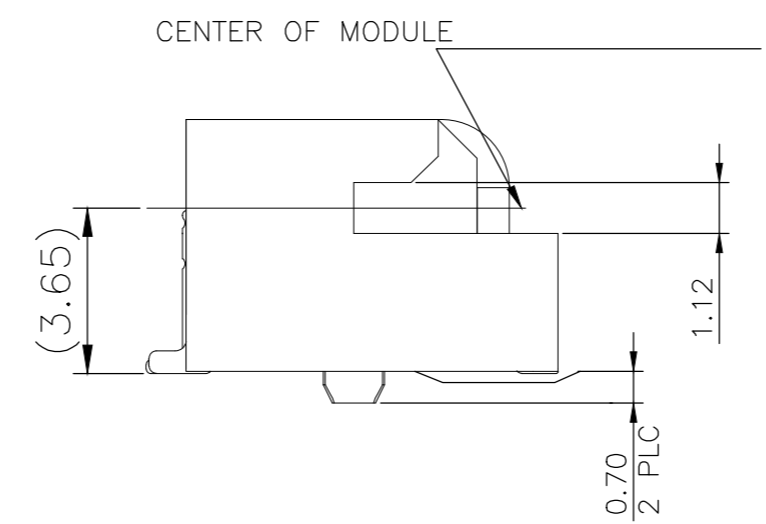
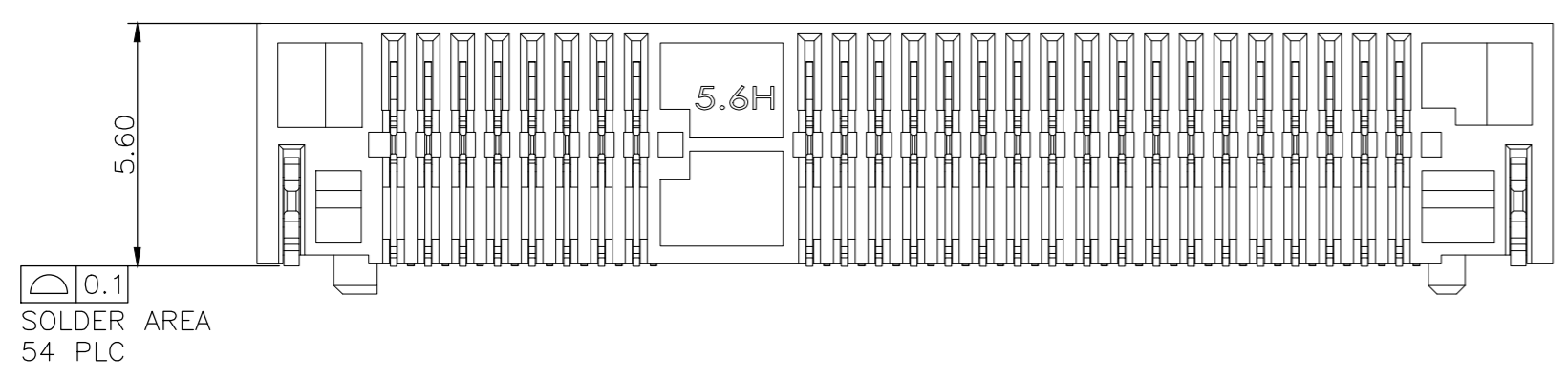
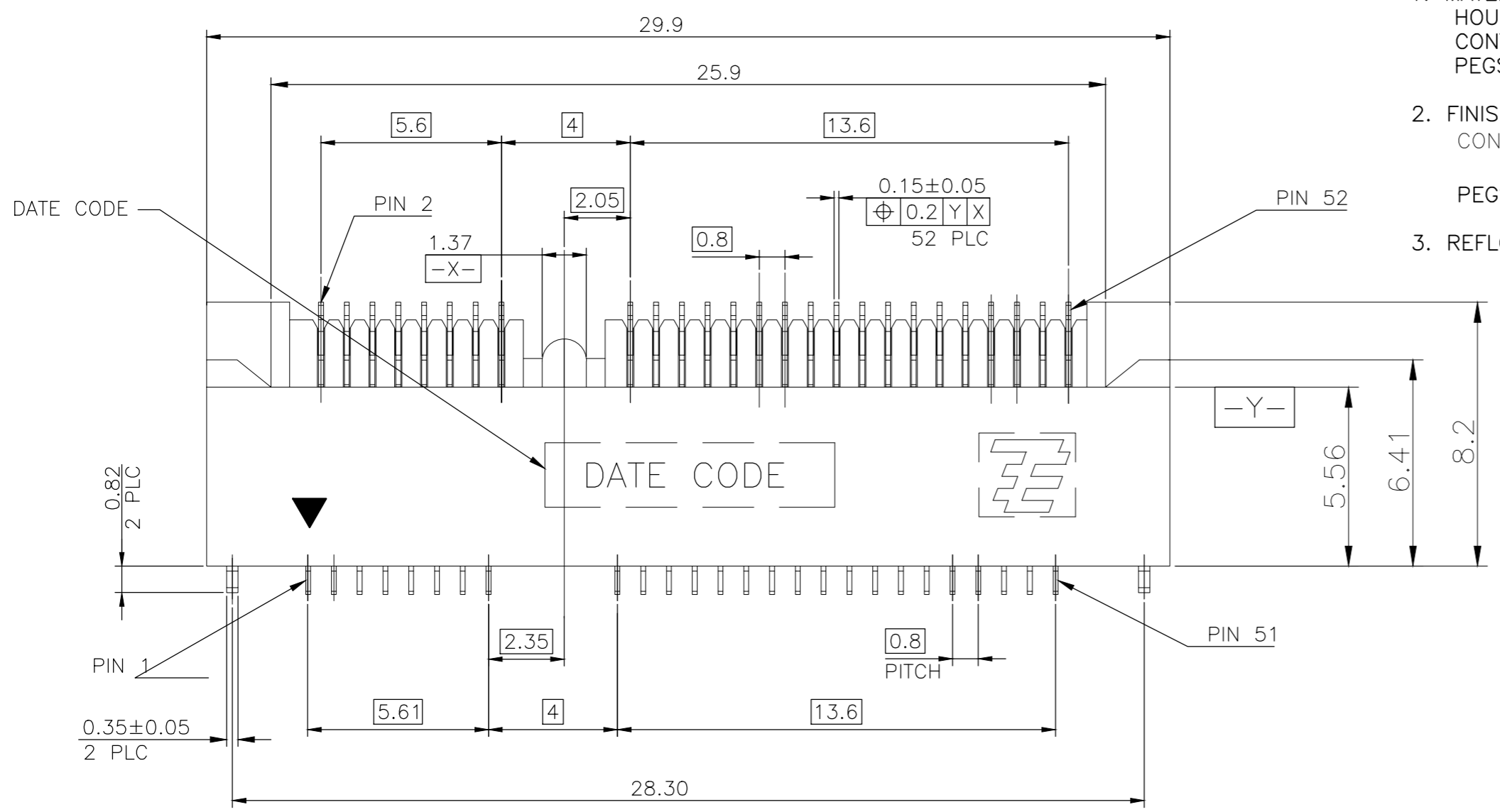

PCI-E MINI CARD CONNECTOR SIGNAL ASSIGNMENTS

PIN#	NAME	PIN#	NAME
51	Reserved	52	+3.3Vaux
49	Reserved	50	GND
47	Reserved	48	+1.5V
45	Reserved	46	LED_WPAN#
43	GND	44	LED_WLAN#
41	+3.3Vaux	42	LED_WWAN#
39	+3.3Vaux	40	GND
37	GND	38	USB_D+
35	GND	36	USB_D-
33	PETp0	34	GND
31	PETn0	32	SMB_DATA
29	GND	30	SMB_CLK
27	GND	28	+1.5V
25	PERp0	26	GND
23	PERn0	24	+3.3Vaux
21	GND	22	PERST#
19	Reserved* (UIM_C4)	20	W_DISABLE#
17	Reserved* (UIM_C8)	18	GND

MECHANICAL KEY			
15	GND	16	UIM_VPP
13	REFCLK+	14	UIM_RESET
11	REFCLK-	12	UIM_CLK
9	GND	10	UIM_DATA
7	CLKREQ#	8	UIM_PWR
5	COEX2	6	1.5V
3	COEX1	4	GND
1	WAKE#	2	3.3Vaux

* Reserved for future UIM interface (if needed)

mSATA CONNECTOR SIGNAL ASSIGNMENTS

PIN#	NAME	PIN#	NAME
51	Presence Detection	52	+3.3V
49	DA/DSS	50	GND
47	Vendor	48	+1.5V
45	Vendor	46	Reserved
43	No Connect	44	Reserved
41	+3.3V	42	Reserved
39	+3.3V	40	GND
37	GND	38	Reserved
35	GND	36	Reserved
33	+A	34	GND
31	-A	32	Two Wire Interface
29	GND	30	Two Wire Interface
27	GND	28	+1.5V
25	-B	26	GND
23	+B	24	+3.3V
21	GND	22	Reserved
19	Reserved	20	Reserved
17	Reserved	18	GND

MECHANICAL KEY			
15	GND	16	Reserved
13	Reserved	14	Reserved
11	Reserved	12	Reserved
9	GND	10	Reserved
7	Reserved	8	Reserved
5	Reserved	6	+1.5V
3	Reserved	4	GND
1	Reserved	2	+3.3V

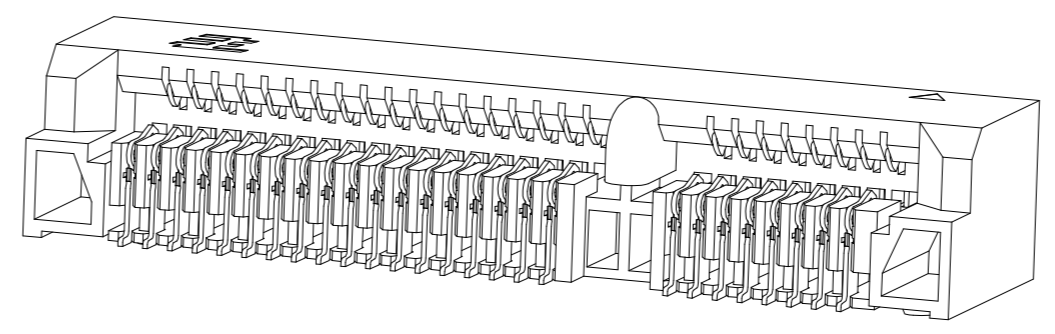
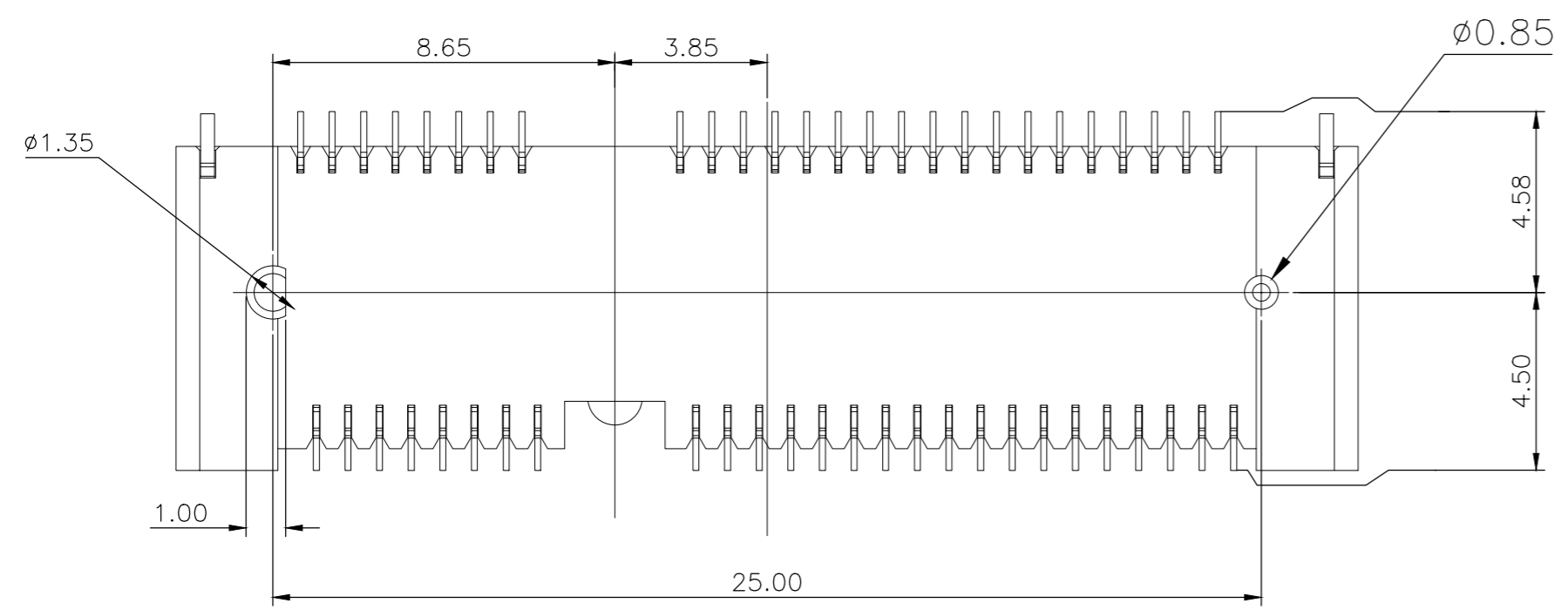

	TYPE II	GOLD FLASH	PART NUMBER
	TYPE II	0.254µm [10µ"]	1775838-6
OBSOLETE	TYPE II	0.254µm [10µ"]	1775838-3
	TYPE I	GOLD FLASH	1775838-2
OBSOLETE	TYPE I	0.254µm [10µ"]	1775838-1
	PACKING TYPE	MIN. GOLD THICKNESS	PART NUMBER

THIS DRAWING IS A CONTROLLED DOCUMENT.		DWN	25SEP2009	TE Connectivity	
DIMENSIONS: mm		A. WU	25SEP2009		
TOLERANCES UNLESS OTHERWISE SPECIFIED:		CHK	S. CHIEN	NAME 2 IN 1 mSATA & PCI EXPRESS MINI CARD CONNECTOR, 5.6 MM HEIGHT	
0 PLC ± -		APVD	W. KODAMA		
1 PLC ± 0.3		PRODUCT SPEC		SIZE	
2 PLC ± 0.2		108-99102		CAGE CODE	
3 PLC ± -		APPLICATION SPEC		DRAWING NO	
4 PLC ± -		-		RESTRICTED TO	
ANGLES ± 3°		WEIGHT		SCALE	
MATERIAL		1.172 GRAMS		SHEET	
FINISH		-		1 of 5	
-		CUSTOMER DRAWING		REV	
				J	

THIS DRAWING IS UNPUBLISHED. RELEASED FOR PUBLICATION
 © COPYRIGHT 2011 BY TE CONNECTIVITY. ALL RIGHTS RESERVED.

REVISIONS					
P	LTR	DESCRIPTION	DATE	DWN	APVD
-	-	SEE SHEET 1	-	-	-

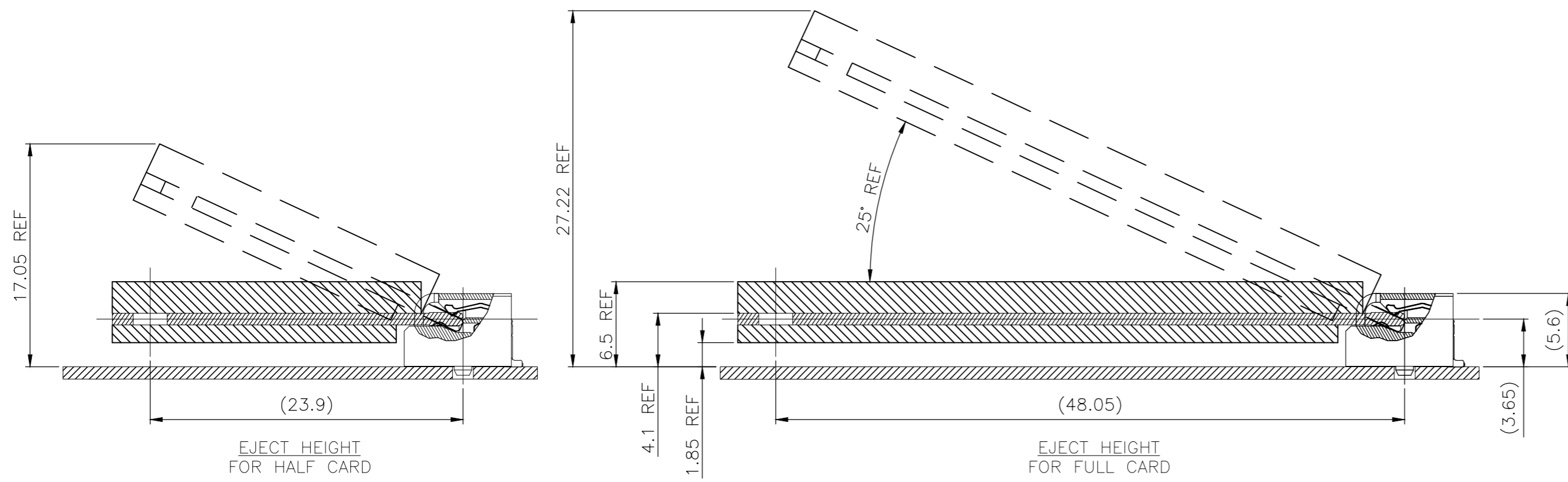

COMPONENT KEEP OUT AREA FOR CARD HOLD DOWN SOLUTION

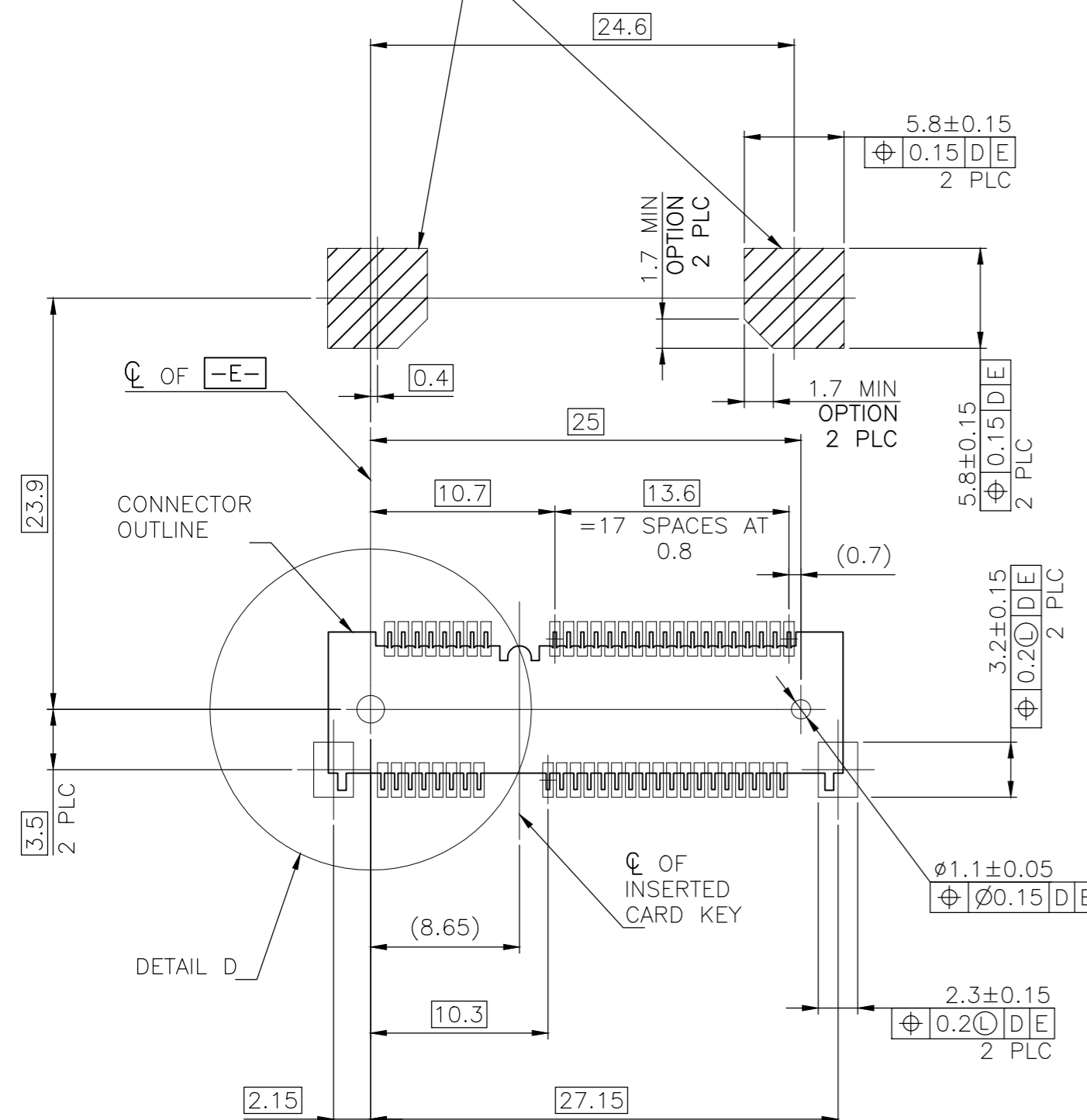

-D- IS THE TOP SURFACE OF PCB.
 RECOMMENDED P.C. BOARD PATTERN LAYOUT FOR HALF CARD CONNECTOR (TOP VIEW)

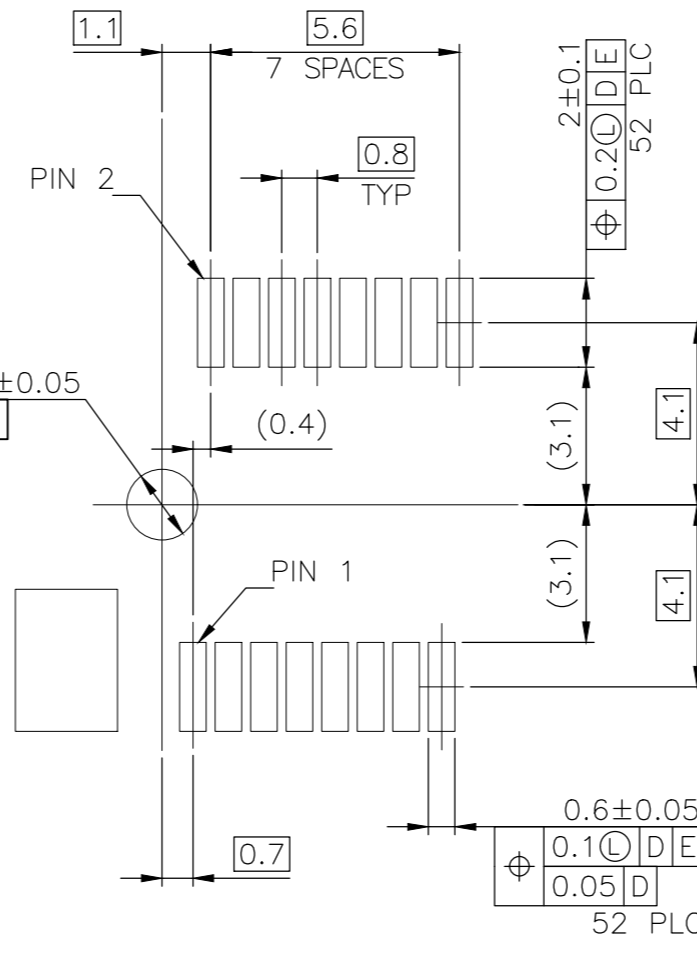

COMPONENT KEEP OUT AREA FOR CARD HOLD DOWN SOLUTION

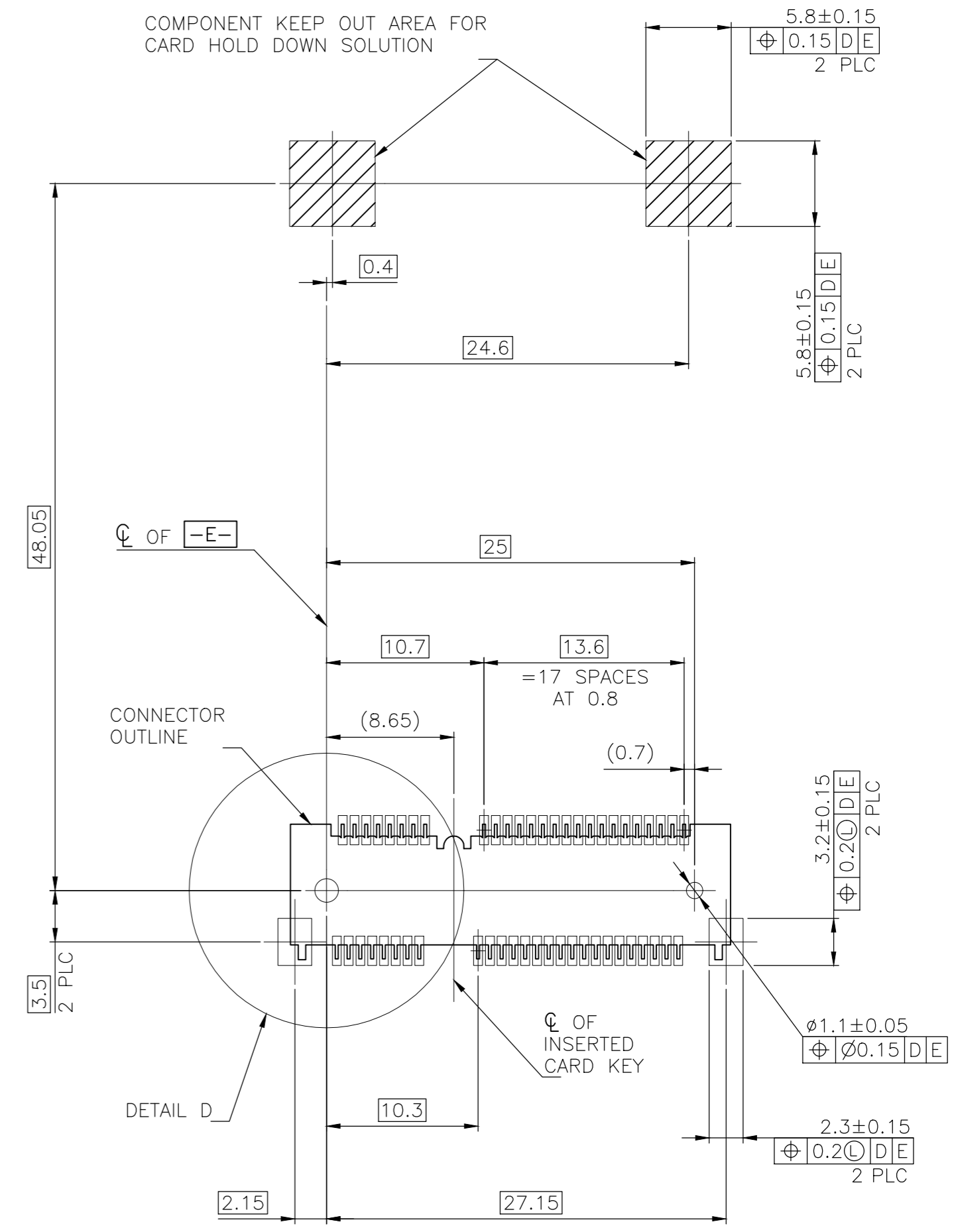

-D- IS THE TOP SURFACE OF PCB.
 RECOMMENDED P.C. BOARD PATTERN LAYOUT FOR FULL CARD CONNECTOR (TOP VIEW)

THIS DRAWING IS A CONTROLLED DOCUMENT.		DWN	01JUN2016	TE TE Connectivity	
DIMENSIONS: mm		CHK	-		
TOLERANCES UNLESS OTHERWISE SPECIFIED:		APVD	-	NAME	
0 PLC	± -	PRODUCT SPEC	-	2 IN 1 mSATA & PCI EXPRESS MINI CARD CONNECTOR, 5.6 MM HEIGHT	
1 PLC	± -	APPLICATION SPEC	-	SIZE	CAGE CODE
2 PLC	± -	WEIGHT	-	A2	00779
3 PLC	± -	CUSTOMER DRAWING	-	DRAWING NO	C=1775838
4 PLC	± -	SCALE	-	SHEET	2 OF 5
ANGLES	± -	REV	J	RESTRICTED TO	
FINISH	-				

THIS DRAWING IS UNPUBLISHED. RELEASED FOR PUBLICATION
 © COPYRIGHT 2011 BY TE CONNECTIVITY. ALL RIGHTS RESERVED.

REVISIONS					
P	LTR	DESCRIPTION	DATE	DWN	APVD
-	-	SEE SHEET 1	-	-	-

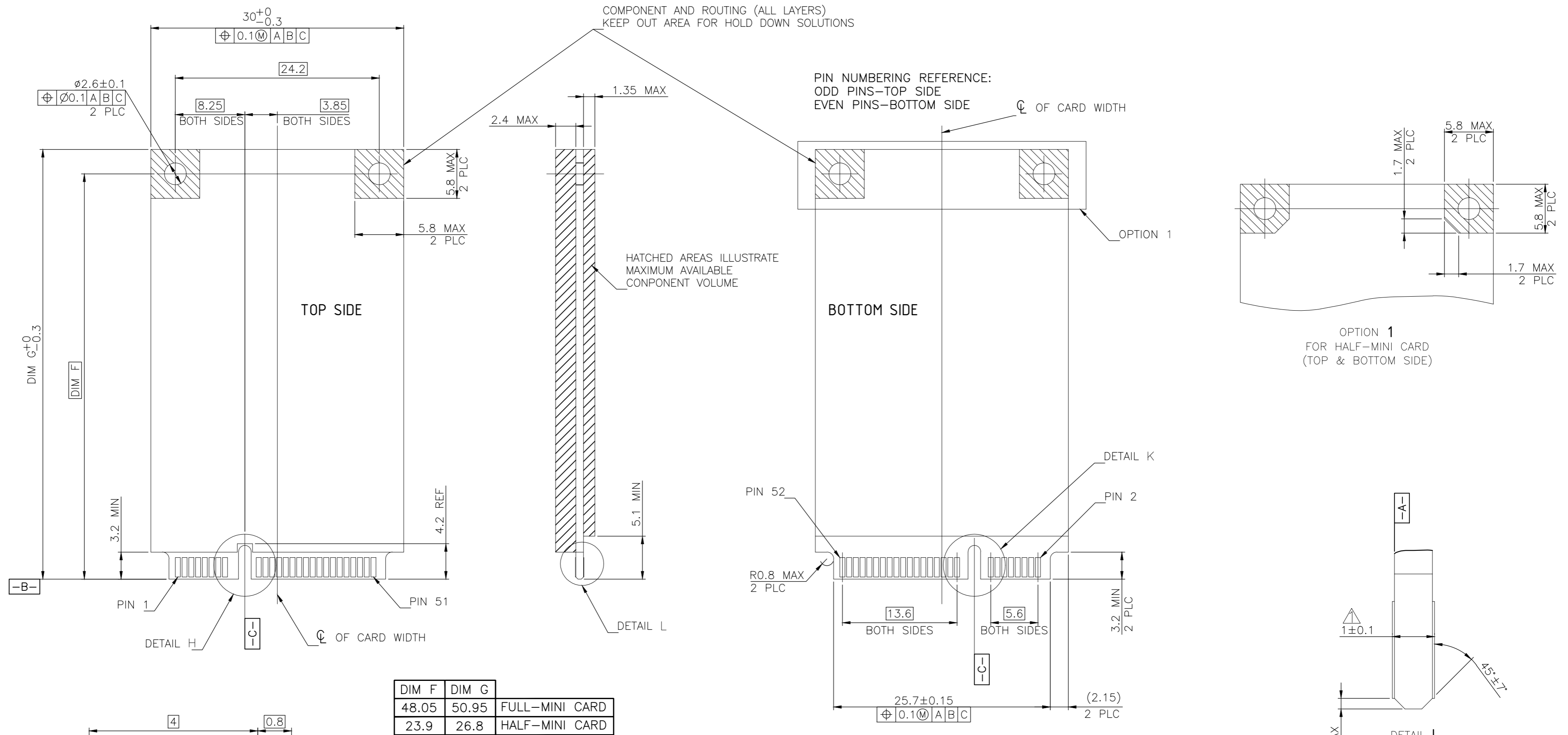

DIM F	DIM G	
48.05	50.95	FULL-MINI CARD
23.9	26.8	HALF-MINI CARD

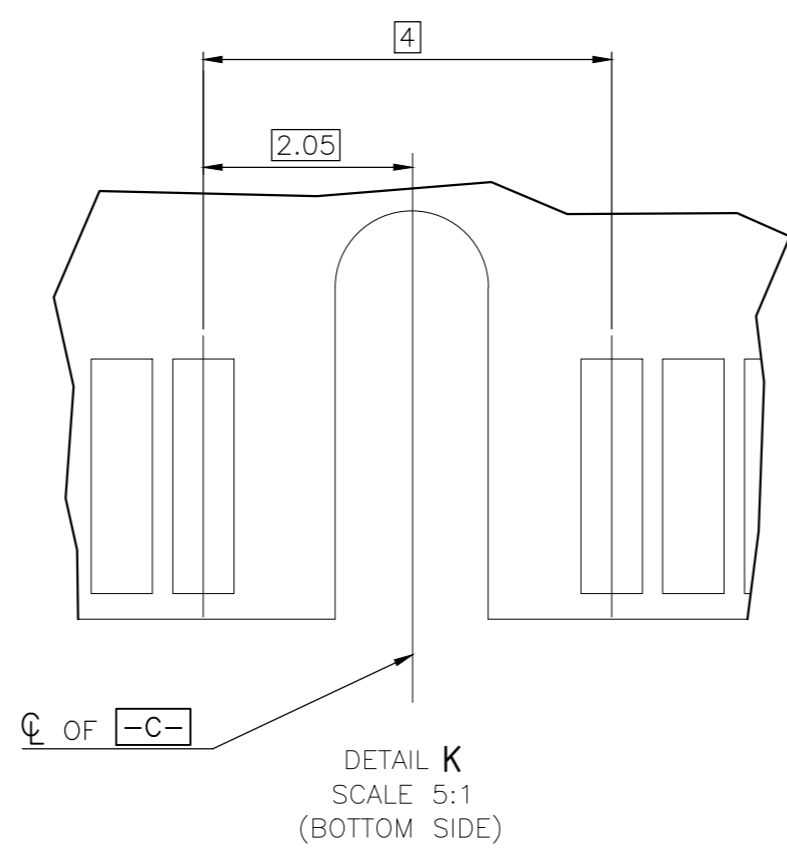
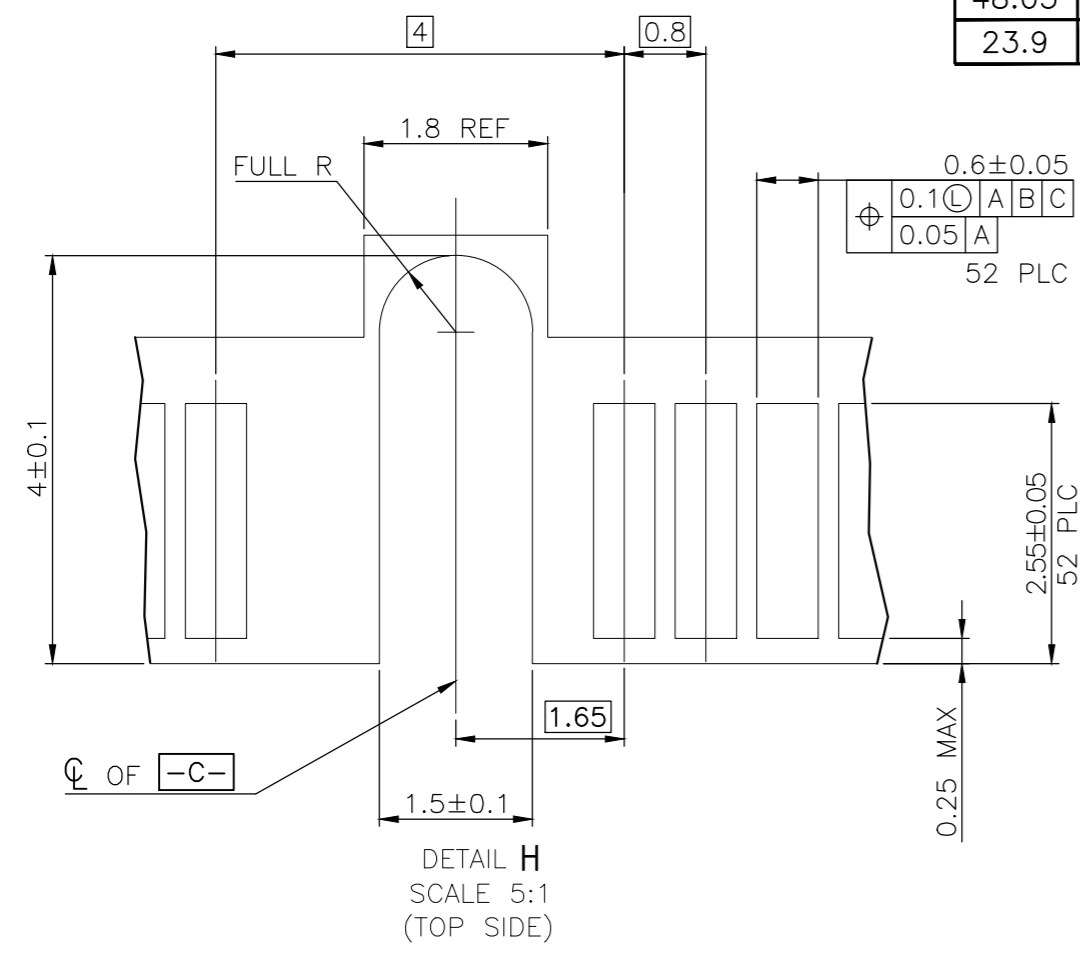

- NOTES:
- ▲ CARD THICKNESS APPLIES ACROSS TABS AND INCLUDES PLATING AND/OR METALLIZATION.
 - ▲ EDGE BEVEL MUST BE PRESENT AND FREE OF CUTTING BURRS FROM PCB AND CONTACT MATERIALS.

FOR PCI EXPRESS MINI CARD

THIS DRAWING IS A CONTROLLED DOCUMENT.		DWN	01JUN2016		
DIMENSIONS: mm		CHK	-		
TOLERANCES UNLESS OTHERWISE SPECIFIED:		APVD	-	NAME	
0 PLC	± -	PRODUCT SPEC	-	2 IN 1 mSATA & PCI EXPRESS MINI CARD CONNECTOR, 5.6 MM HEIGHT	
1 PLC	± -	APPLICATION SPEC	-	SIZE	CAGE CODE
2 PLC	± -	WEIGHT	-	A2	00779
3 PLC	± -	CUSTOMER DRAWING	-	DRAWING NO	C=1775838
4 PLC	± -	SCALE	-	SHEET	3 OF 5
ANGLES	± -	RESTRICTED TO	-	REV	J
FINISH	-				

THIS DRAWING IS UNPUBLISHED. RELEASED FOR PUBLICATION
 © COPYRIGHT 2011 BY TE CONNECTIVITY. ALL RIGHTS RESERVED.

REVISIONS					
P	LTR	DESCRIPTION	DATE	DWN	APVD
-	-	SEE SHEET 1	-	-	-

COMPONENT AND ROUTING (ALL LAYERS)
 KEEP OUT AREA FOR HOLD DOWN SOLUTIONS

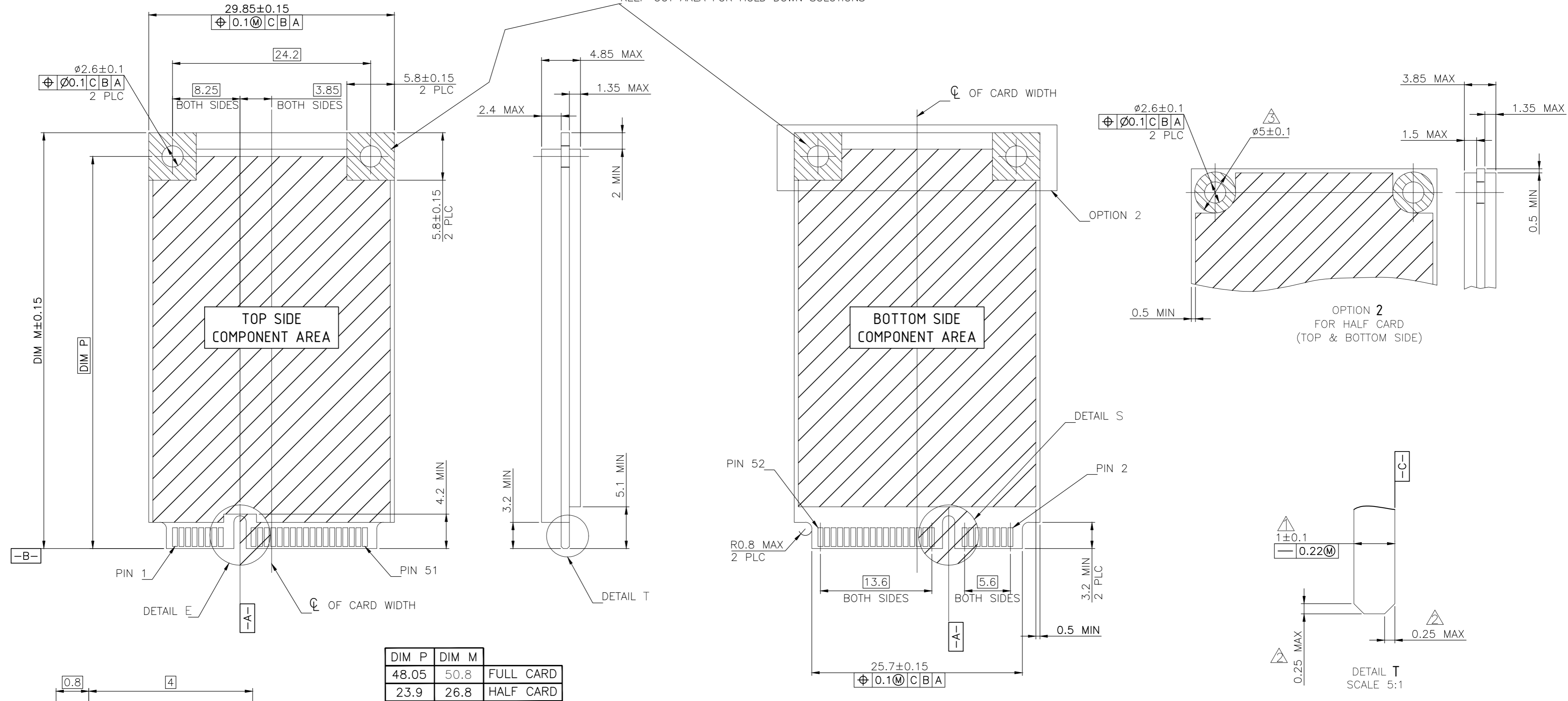

DIM P	DIM M	
48.05	50.8	FULL CARD
23.9	26.8	HALF CARD

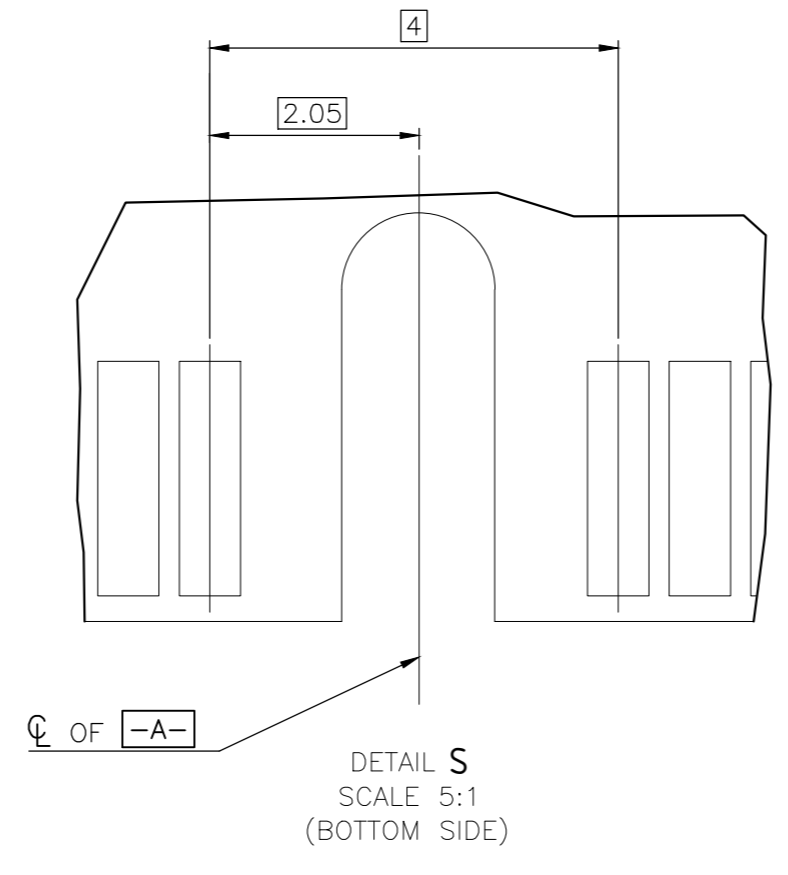
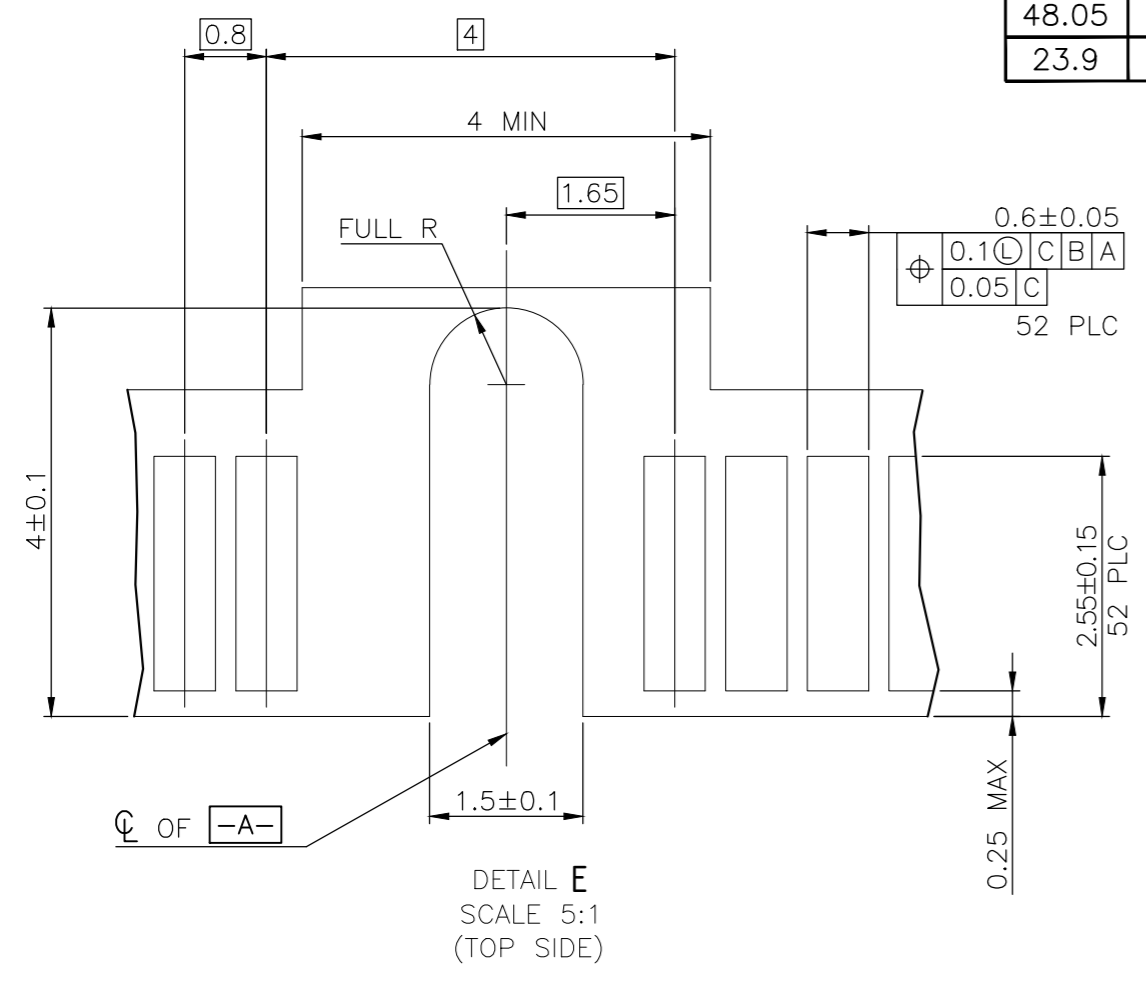

- NOTES:
- ▲ CARD THICKNESS APPLIES ACROSS TABS AND INCLUDES PLATING AND/OR METALLIZATION.
 - ▲ EDGE BEVEL MUST BE PRESENT AND FREE OF CUTTING BURRS FROM PCB AND CONTACT MATERIALS.
 - ▲ COMPONENT AND ROUTING (TOP/BOTTOM LAYER) KEEP OUT AREA FOR HOLD DOWN SOLUTIONS.

FOR mSATA

THIS DRAWING IS A CONTROLLED DOCUMENT.		DWN	01JUN2016	TE TE Connectivity	
DIMENSIONS: mm		CHK	-		
TOLERANCES UNLESS OTHERWISE SPECIFIED:		APVD	-	NAME	
0 PLC ± -		PRODUCT SPEC	-	2 IN 1 mSATA & PCI EXPRESS MINI CARD CONNECTOR, 5.6 MM HEIGHT	
1 PLC ± -		APPLICATION SPEC	-	SIZE	CAGE CODE
2 PLC ± -		WEIGHT	-	A2	00779
3 PLC ± -		CUSTOMER DRAWING	-	DRAWING NO	C=1775838
4 PLC ± -		SCALE	-	SHEET	4 OF 5
ANGLES ± -		FINISH	-	REV	J
FINISH		RESTRICTED TO	-		

THIS DRAWING IS UNPUBLISHED. RELEASED FOR PUBLICATION
 © COPYRIGHT 2011 BY TE CONNECTIVITY. ALL RIGHTS RESERVED.

REVISIONS					
P	LTR	DESCRIPTION	DATE	DWN	APVD
-	-	SEE SHEET 1	-	-	-

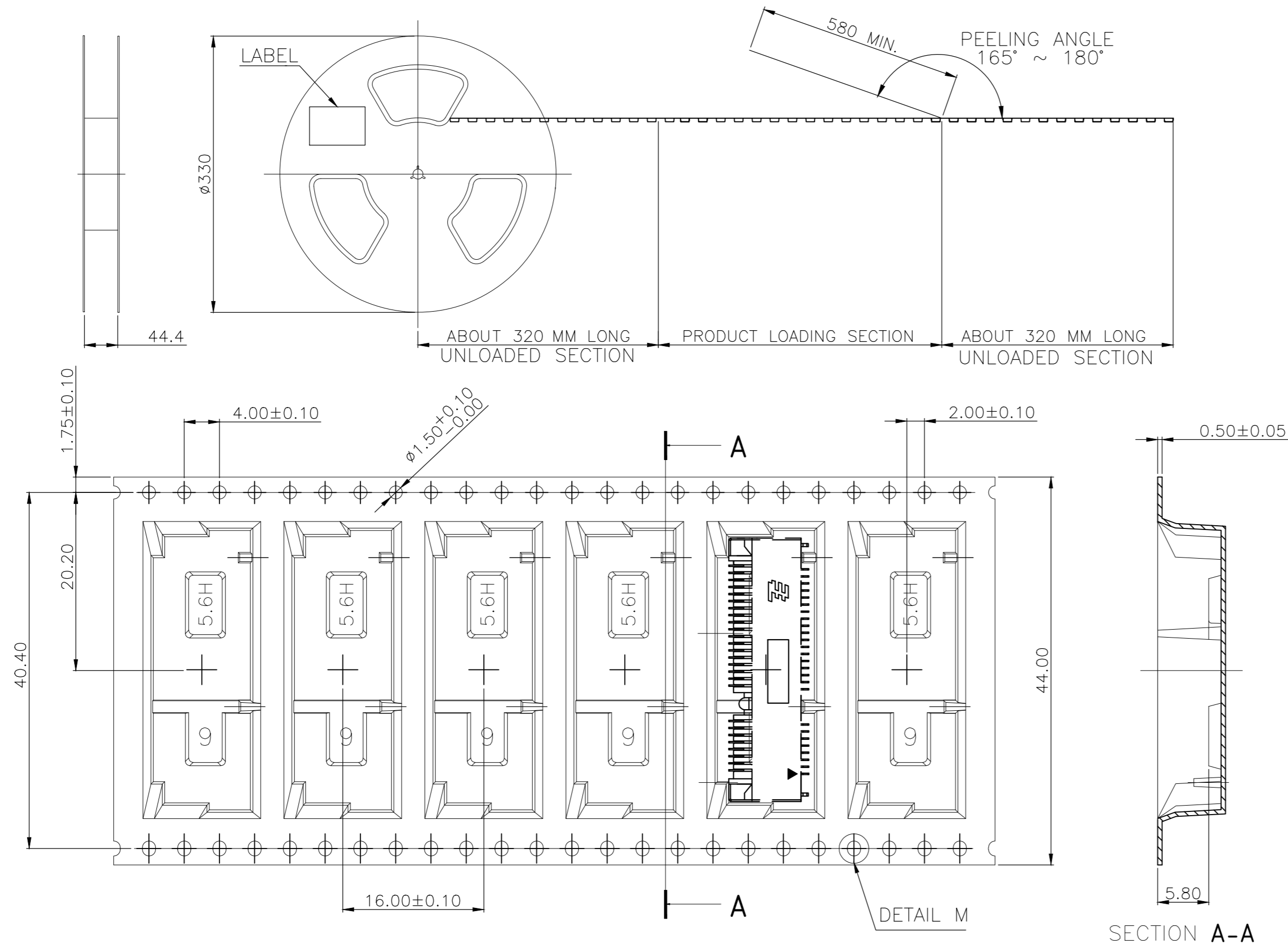

NOTES:

- MATERIAL:
 BOX: FIBREBOARD, CORRUGATED, DOUBLE WALL.
 COVER TAPE: POLYSTYRENES, TRANSPARENT COLOR.
 CARRIER TAPE: POLYSTYRENES, TRANSPARENT COLOR.
 REEL: HIPS, BLUE COLOR.
 BAG: POLYETHYLENES, TRANSPARENT COLOR.
- EACH BAG SHALL BE INCLUDED DESICCANT.
- PEELING STRENGTH: 0.1 ~ 1.3 N (10 ~ 130 GRAMS).
- PEELING SPEED: 300 mm/min.

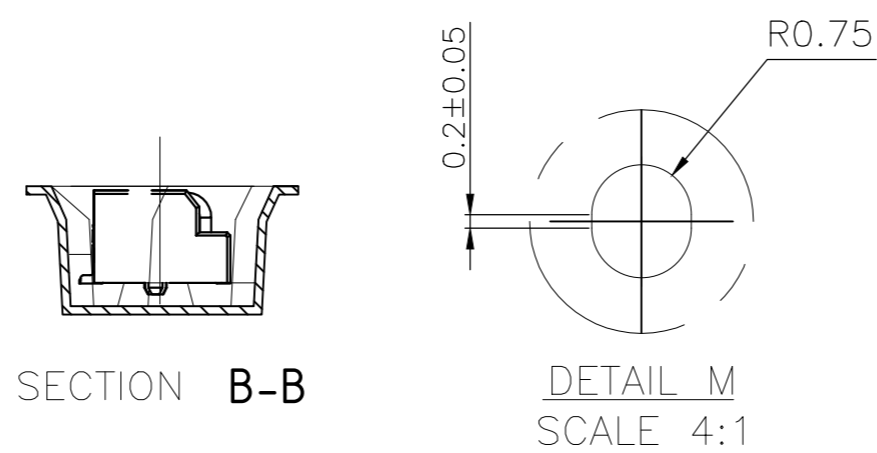
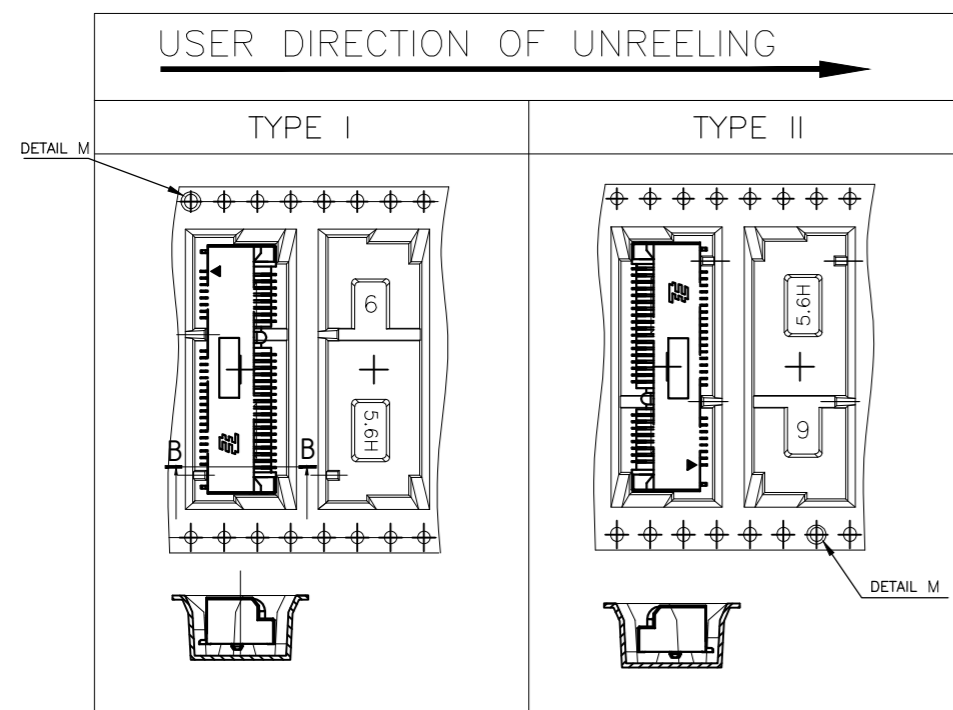
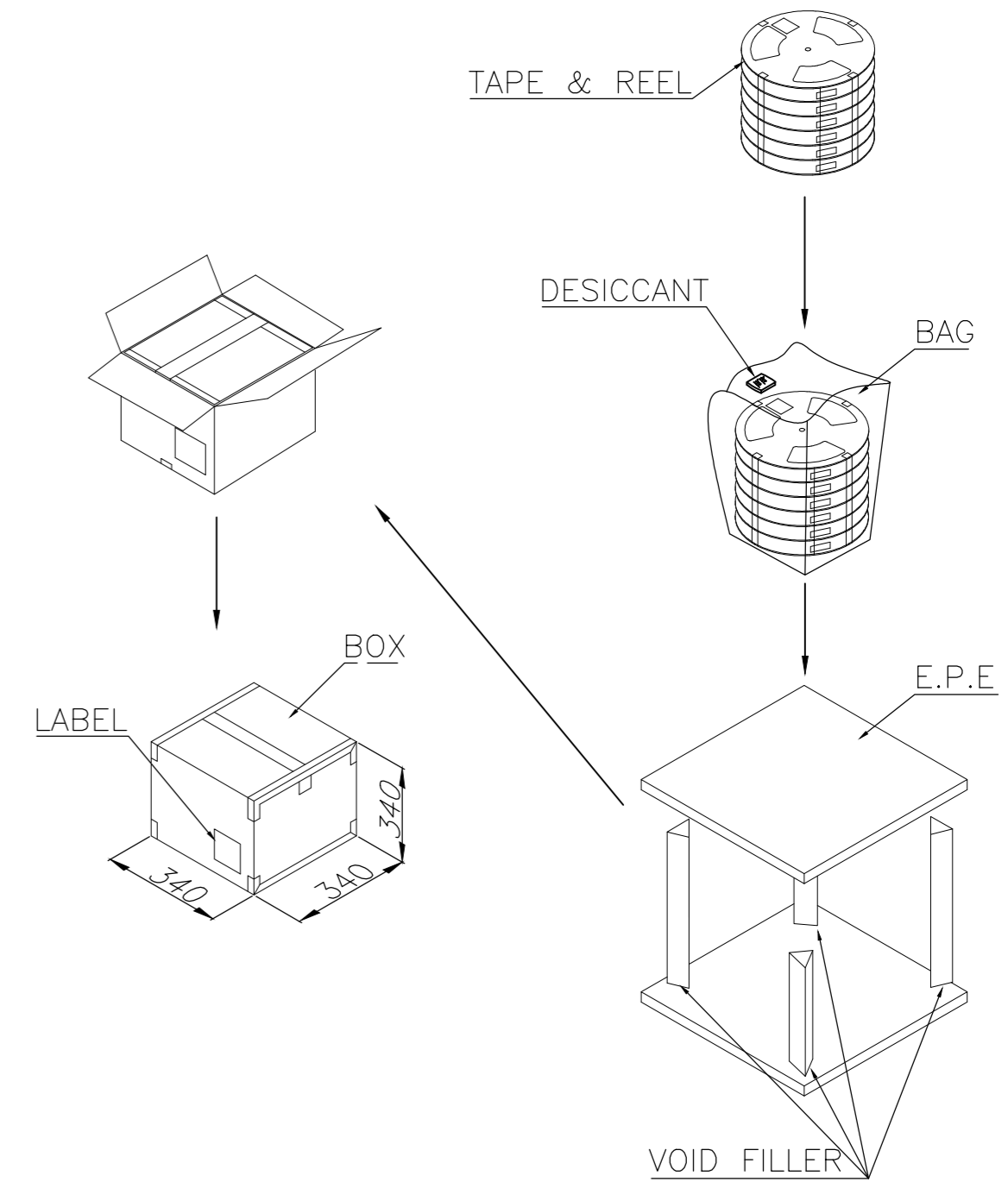

SECTION A-A

SECTION B-B

DETAIL M
SCALE 4:1

3000 PCS	500	6	9.86	4.98
QUANTITY	PCS/TAPE	REELS/BOX	G/W(Kg)	N/W(Kg)

THIS DRAWING IS A CONTROLLED DOCUMENT.		DWN	01JUN2016	TE Connectivity	
DIMENSIONS: mm		CHK	-	NAME	
TOLERANCES UNLESS OTHERWISE SPECIFIED:		APVD	-	2 IN 1 mSATA & PCI EXPRESS MINI CARD CONNECTOR, 5.6 MM HEIGHT	
0 PLC ± -		PRODUCT SPEC	-	SIZE	CAGE CODE
1 PLC ± -		APPLICATION SPEC	-	A2	00779
2 PLC ± -		WEIGHT	-	DRAWING NO	C=1775838
3 PLC ± -		CUSTOMER DRAWING	-	RESTRICTED TO	-
4 PLC ± -		SCALE	-	SHEET	5 of 5
ANGLES ± -		REV	J		
FINISH					

单击下面可查看定价，库存，交付和生命周期等信息

[>>TE Connectivity\(泰科\)](#)