

THIS DRAWING IS UNPUBLISHED. RELEASED FOR PUBLICATION 20  
 © COPYRIGHT 20 BY - ALL RIGHTS RESERVED.

LOC	DIST	REVISIONS					
AF	50	P	LTR	DESCRIPTION	DATE	DWN	APVD
		B5		REVISED PER ECO-18-007263	09MAY2018	RS	DS
		B6		REVISED PER ECR-19-006167	07MAY2019	BDA	DH
		B7		REVISED PER ECR-19-017221	28JAN2020	BDA	DS

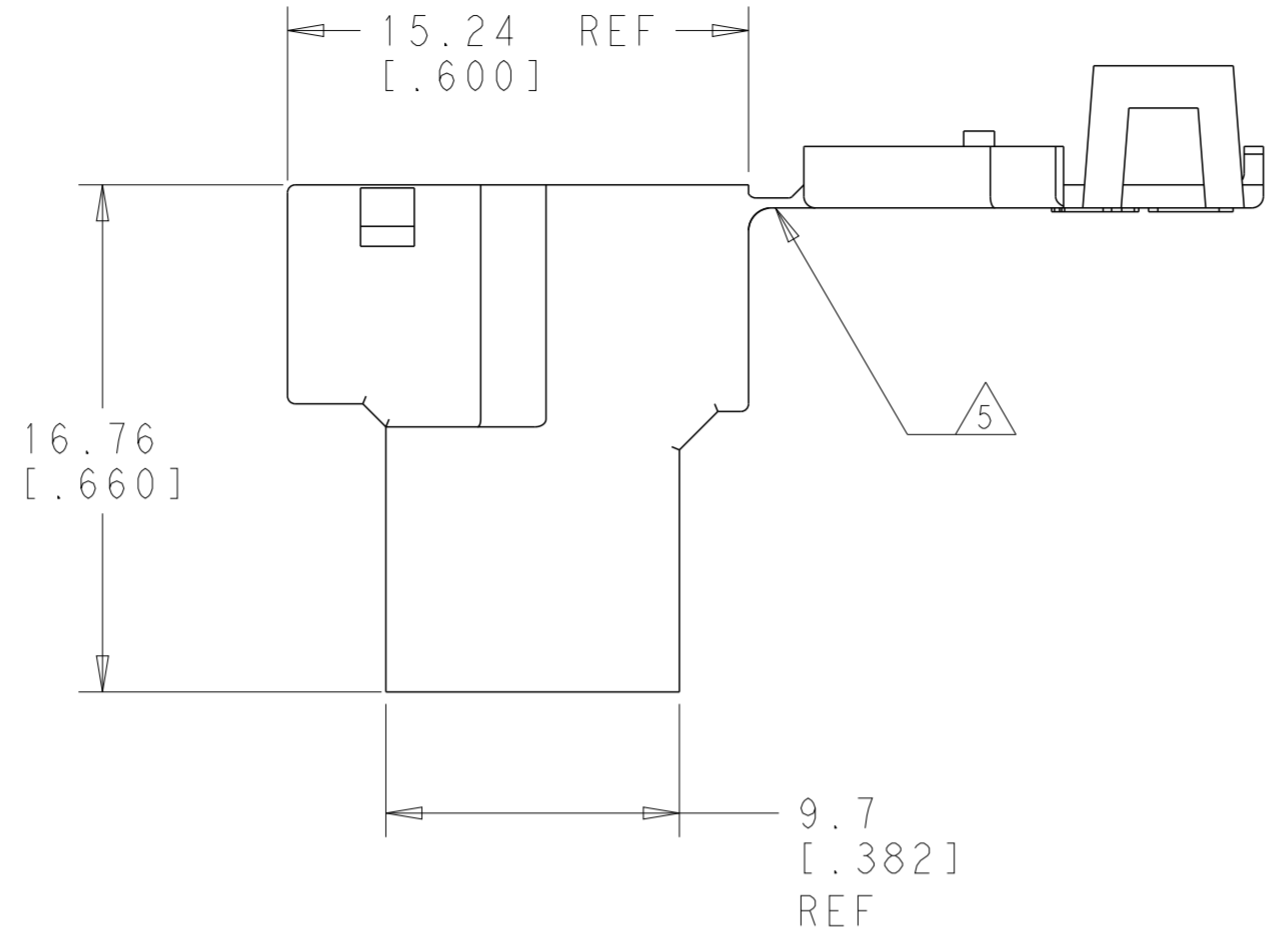

- ① MATERIAL -NATURAL, 6 NYLON, 150°C, V0
- ② MATERIAL -BLACK, 6 NYLON, 150°C, V0
- ③ MATERIAL -NATURAL, 66 NYLON, V2, GLOW WIRE MATERIAL
- ④ MATERIAL - NATURAL 66 NYLON V0, GLOW WIRE MATERIAL
- ⑤ IF CRACKS IN THE LIVING HINGE ARE OBSERVED DURING CLOSING THE LID, THIS IS AN INDICATION THAT THE PARTS HAVE BEEN ALLOWED TO DRY-OUT TOO MUCH. RE-MOISTURIZE THE PARTS PER SPECIFICATION 408-143119.

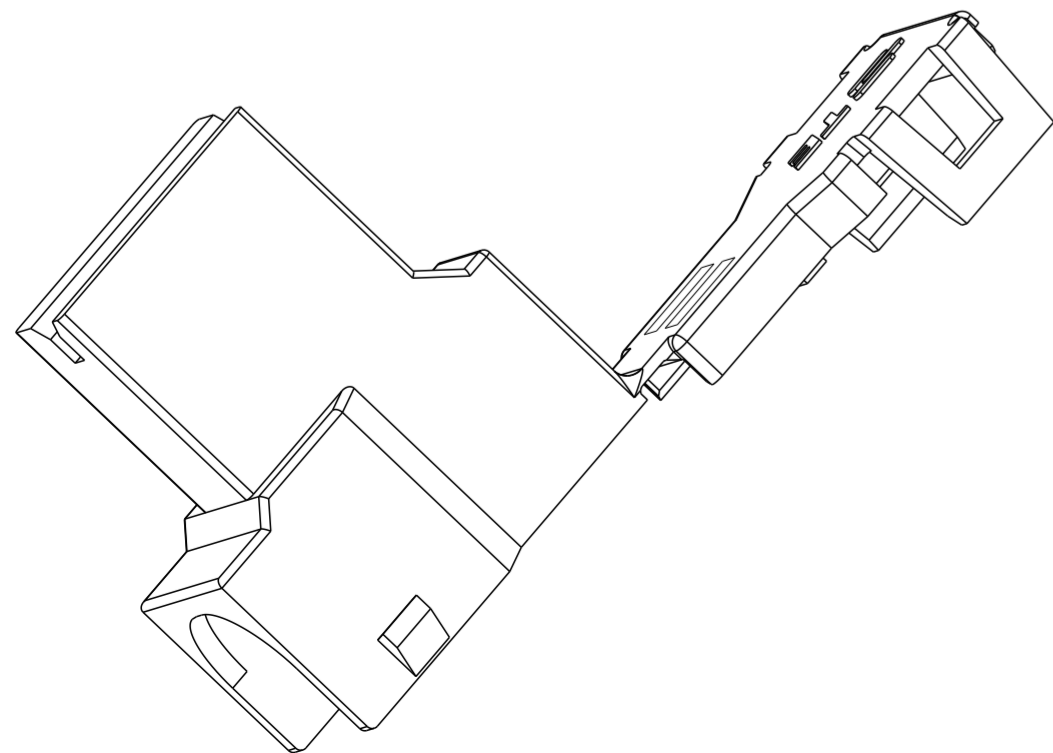
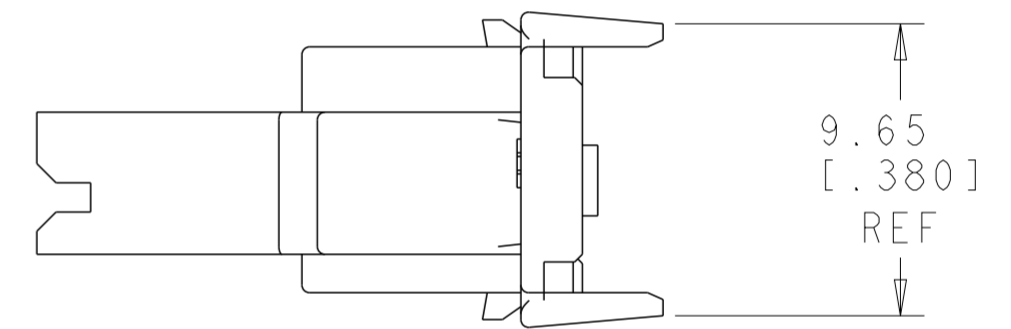
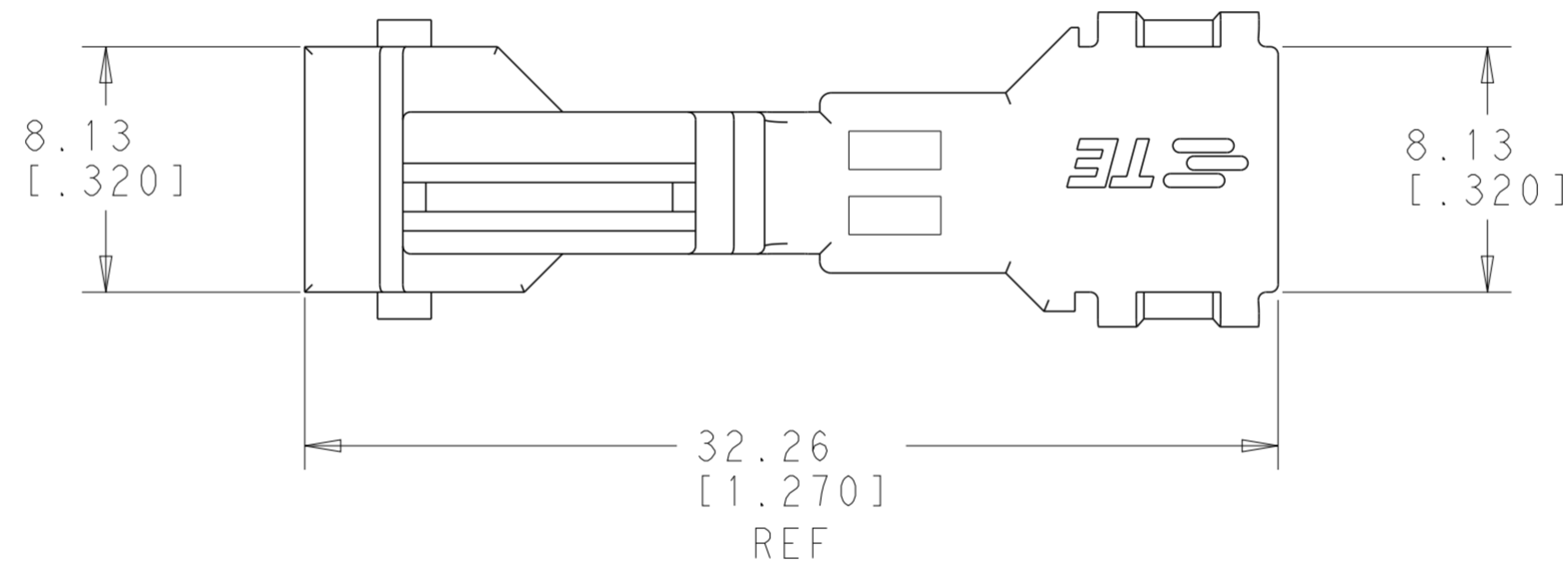
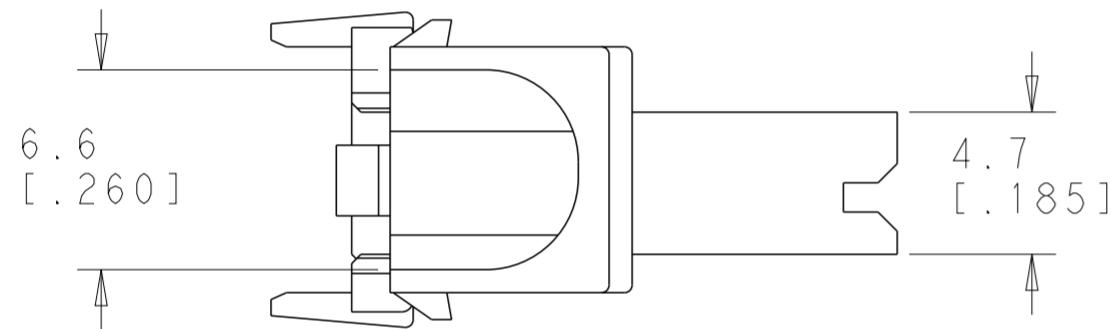

SUPERSEDED BY 1969507-9

④	1969507-9
③	<del>1969507-4</del>
②	1969507-3
①	1969507-2
MATERIAL	PART NO.

DIMENSIONS:		TOLERANCES UNLESS OTHERWISE SPECIFIED:		DWN		CHK		APVD		NAME	
mm	[INCHES]	0 PLC	±	JR RUTH	03APR12	PEITE DESANTIS	03APR12	PEITE DESANTIS	03APR12	HOUSING, RECEPTACLE, FLAG FASTON, CLOSED BACK, .250 SERIES	
1 PLC	±	2 PLC	±0.38 [.015]	APPLICATION SPEC		PRODUCT SPEC		SIZE		CAGE CODE	DRAWING NO
3 PLC	±	4 PLC	±	WEIGHT		-		A200779		C-1969507	RESTRICTED TO
ANGLES	±	FINISH	±	CUSTOMER DRAWING		SCALE 4:1		SHEET 1 OF 1		REV B7	

单击下面可查看定价，库存，交付和生命周期等信息

[>>TE Connectivity\(泰科\)](#)